

BİZ FARKLIYIZ FARKINDA MISINIZ!
WE ARE DIFFERENT ARE YOU AWARE!



444 3942



alparslantarim.com



BİZ FARKLIYIZ FARKINDA MISINIZ!
ARE YOU AWARE THAT WE ARE DIFFERENT!



ALPARSLAN

■ 1969 yılında kurulan ve Konya'nın köklü sanayi kuruluşları arasında yer alan Alparslan Tarım Makinaları Sanayii ve Ticaret A.Ş. Konya 4. Organize Sanayi bölgesinde 30.000 m² si kapalı toplam 50.000 m² alanda faaliyetine devam etmektedir. Tarım makineleri, ön yükleyici ve arka kazıcılar alanında üretim yapan Alparslan Tarım, tüketicisine her yıl daha kapsamlı, daha teknolojik ürünler sunmaktadır. Ayrıca 2000 yılından buyana new holland traktörleri, biçer döver ve zirai ekipmanları İç Anadolu bölge bayiliğini yürüten Alparslan Tarım tüketicisine tam hizmet sunmaktadır

■ *The Alparslan Agricultural Machinery industry and trade Co., Ltd which was founded in 1969 and is among the oldest industrial organizations in Konya, continues to operate in the 4th organized industrial region of Konya in a total of 50.000 m² area from which 30.000 m² is covered. Agricultural machinery, front loader and backhoe loader Alparslan producing in the field of agriculture, more technological products to its customers. In addition, the Alparslan agriculture who holds the dealership of New Holland tractors, harvesters and agricultural equipment in Central Anatolia since 2000, offers full service to its customers.*

.....

■ ÜRÜNLER / PRODUCT

- Ön Yükleyici / *Front Loader*
 - Arka Kazıyıcı / *Backhoe Loader*
 - Balya Toplama Makinesi ve Yükleme Ataşmanı / *Bale Acquisition Machine and Loading Attachment*
 - Elemeli Savurmalı Kombine Harman Makinesi / *The elimination winnowing combine Harvester*
 - Depolu Mobil Sistem Harman Makinesi / *Machine Dual Band Mobile Systems*
 - Kombine Hububat Ekim Makinası / *The Combine Grains Planting Machine*
 - Kayar Şase Pnömatik Hassas Ekim Makinesi / *Sliding Frame Pneumatic Precision Seeder*
 - Diskli Tip Pnömatik Hassas Ekim Makinası Hidrolik & Manuel Kaydırmalı / *Disc Type Pneumatic Precision Drills Hydraulic & Manual Shifted*
-

■ İHRACAT YAPILAN ÜLKELER / EXPORTING COUNTRIES

- Fas / *Fas*
- Yemen / *Yemen*
- Mısır / *Egypt*
- Sudan / *Sudan*
- Cezayir / *Algeria*
- Kırgızistan / *Kirghizistan*
- İran / *Iran*
- Irak / *Iraq*
- Suriye / *Syria*
- Tunus / *Tunis*
- Makedonya / *Macedonia*
- Slovenya / *Slovenia*
- Yunanistan / *Greece*
- Fransa / *France*

ALP-07

ÖN YÜKLEYİCİ PLATIN / PLATIN FRONT LOADER



Hidrolik bağlantı elemanı



Hızlı ataçman sökme-takma adaptörü



Kumanda kolu



Anti-şok sistemi



Dengeleme sistemi

Platin, Titanium, Gold, Silver ve yeni ürün Uranium olarak gruplandırılan Ön Yükleyiciler Türkiye' de ilk ve tek patentli olarak firmamız tarafından 20 hp ila 170 hp arası Zirai Traktörler için üretilmiştir. Farklı özelliklere sahiptirler ve 3 dakikada söküp takılabilen portatif üründür. Muhtelif emtiyaların yükleme, küürme ve boşaltmasında kullanmak üzere çeşitli iş Ataşmanları geliştirilmiştir.

Platinum, Titanium, Gold, Silver and new product Uranium Turkey's first and only patented grouped as front loaders agricultural tractors between 20 HP for 170 HP and manufactured by our company. In 3 minutes and have different features, detachable a portable product. The installation of various commodities, and various attachments to offload kurume business was developed.



URANIUM
120-170 Hp



PLATIN
65-140 Hp



TITANIUM
65-140 Hp



GOLD
45-90 Hp
Bahçe Tipi / Garden Type



SILVER
20-40 Hp

ALP-07

ÖN YÜKLEYİCİ URANIUM / FRONT LOADER 120-170 Hp

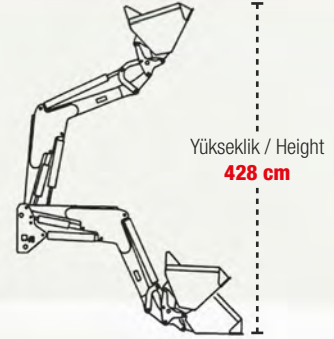

Teknik Özellikler / Technical Features

	Silver	Gold	Titanium	Platin	Uranium
Max Kaldırma Yüksekliği (Menteşe) / Max Lifting height (Hinge)	2450 mm.	3200 mm.	3730 mm.	3860 mm.	4280 mm.
Max Kaldırma Yüksekliği (Kova altı) / Max Lifting height (Under bucket)	2250 mm.	3050 mm.	3560 mm.	3650 mm.	4110 mm.
Boşaltma Yüksekliği / Emptying Height	2050 mm.	2700 mm.	2850 mm.	2940 mm.	3420 mm.
Max. Yükseklikle Taşıma Açısı / Transporting angle at Max. height	45 deg.	45 deg.	45 deg.	45 deg.	45 deg.
Max. Yükseklikte Boşaltma Açısı / Emptying angle at Max. height	55 deg.	55 deg.	55 deg.	55 deg.	55 deg.
Min. Yükseklikte Toplama Açısı / Collecting angle at Min. height	45 deg.	45 deg.	45 deg.	45 deg.	45 deg.
Zeminden Koparma Kapasitesi / Breaking off capacity from ground	750 Kg.	1300 Kg.	1900 Kg.	1900 Kg.	1900 Kg.
Max. Yükseklikte Taşıma Kapasitesi / Transporting capacity at Max. height	775 Kg.	1200 Kg.	1800 Kg.	1800 Kg.	1800 Kg.
Ataçman Dengeleme Sistemi / Attachment Balancing system	Mekanik	Mekanik	Mekanik	Hidrolik	Hidrolik
Anti-Şok Sistemi / Anti-flock System	Opsiyonel	Opsiyonel	Opsiyonel	Standart	Standart
Joystick Kumanda Sistemi / Joystick Controlling system	Standart	Standart	Standart	Standart	Standart
Hareketli Ataçman Hidrolik Valfi / Movable Attachment Hydraulic valve	Opsiyonel	Opsiyonel	Standart	Standart	Standart
Ataçman Sökme-Takma Adaptörü / Attachment Dismantle-Fixing Adapter	Standart	Standart	Standart	Standart	Standart
Ön Yükleyici Ağırlığı / Front Loader weight	250 Kg.	550 Kg.	610 Kg.	670 Kg.	770 Kg.
Gerekli Traktör Güç Aralıkları / The needed tractor power ranges	20-40 Hp	45-90 Hp	65-140 Hp.	65-140 Hp	120-170 Hp



İş kovası
Work bucket



Toprak kovası
Soil bucket



Tahıl kovası
Grain bucket



Parmaklı kova
Finger type bucket



Asansörlü pancar kovası
Beet bucket with lift



Asansörlü tahıl kovası
Grain bucket with lift



Balya tutucu
Bale holder



Pamuk tutucu
Cotton holder



Bigbag ataşmanı yüksek ayarlı
Bigbag attachments high adjusted



Sabit kare balya çatalı
Square bale fork



Asansörlü kare balya çatalı
Square bale fork with lift



Forklift çatalı
Forklift fork



Hidrolik kaydırmalı forklift çatalı
Forklift fork hydraulic shift



Tomruk tutucu
Log holder



Kar küreği
Snow shovel

ALP-08 BKY 250

ARKA KAZICI / BACKHOE LOADER

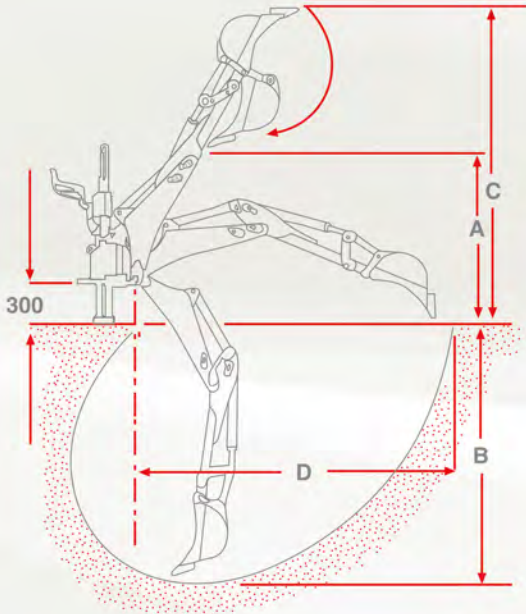

Teknik Özellikler / Technical Specifications

	BKY 250
Kova Patlatma Gücü / Bucket Bursting Strength	2600
Kol Dönüş Açısı / Level Turning angle	180°
Pompa Kapasitesi / Pump Capacity	16
Gerekli Sistem Basıncı / Required System Pressure	180
Kova Ölçüsü / Bucket size	40
Standart Kovayla Birlikte Ağırlığı / Standard Weight together with bucket	555

Teknik Özellikler / Technical Specifications

	A	B	C	D
BKY 250	2050	2500	2880	3010

- ALP-08 serisi traktör arka kazıcılar 3 nokta askı bağlantı sistemiyle, traktör arka hidrolik askı kollarına bağlanmaktadır. Kolay bağlanabilir olmasının yanı sıra kilitleme sisteminin pernelarla yapılması güvenli kazma işlemi yapılmasını sağlamaktadır.
 - Traktör kuyruk miline takılan hidrolik pompa kuyruk mili hareketiyle, hidrolik pompa sisteme hidrolik yağ basıncı sağlar ve kumanda kontrolüyle hidrolik silindireler giden hidrolik yağ kolların hareketlerini sağlar.
 - ALP-08 BKY SERİSİ, sabit şase olup, genelde açık alanlarda ve bahçelerde çalışma yapan müşterilerimiz için üretilmiştir. Dengeleyici ayakların geniş noktalara ulaşması maksimum denge sağlar ve ayaklar katlandığı zaman ise ergonomik ölçülere gelmesini sağlamaktadır.
 - Bağlama ve sökme sistemlerinin kolay olması tecrübesi olmayan kullanıcılar için bile pratik ve kolay yapılmasını sağlar. Çalışma esnasında traktörü aşırı yüklerden korumak için, yük dengeleyici ayaklar üzerine dağılacak şekilde tasarlanmıştır. Çalışma sistemi kolay ve basittir.
 - ALP-08 SERİSİ TRAKTÖR ARKA KAZICILAR uygun fiyat avantajlarıyla, mükemmeli arayan müşterilerimiz için özel olarak üretilmiştir.
- *ALP-08 series rear scrapers of tractors are connected to the rear hydraulic suspension arms with a 3-point linkage system. With its easy-connected structure as well as bolt locking system has been made with pins enable a safe digging process.*
 - *Hydraulic pump attached to the tail shaft of the tractor, with the tail movement, provides hydraulic oil pressure and allows the movement of hydraulic oil arm with control system goes with control hydraulic cylinders.*
 - *ALP-08 BKY SERIES has a constant chassis, and it is designed for customers who usually work in open spaces and gardens. Reaching the widest point of the stabilizer legs provides maximum stability and when feet are folded, it provides ergonomic dimensions.*
 - *Easiness of binding and dismantling systems provides practical use for even users who have no experience. In order to protect the tractor from the excessive loads during operation, it is designed to spread the load leveling feet. The operating system is quick and simple.*
 - *ALP-08 SERIES TRACTOR REAR SCAPERS with its advantage of affordable prices, is tailor-made for our clients seeking perfectness.*



ALP-04 CEREN

BALYA TOPLAMA MAKİNESİ /

BALE ACQUISITION MACHINE



Alp-04 Ceren Balya Toplama Makinesi ve Yükleme Ataçmanı firmamız tarafından Türkiye' de ilk ve tek olarak üretilmiştir. Patentli olan ürün balya'nın toplanmasında büyük kolaylıklar sağlamaktadır. Kullanımı çok basit olan makina balya yapma makinenizin arkasına, uygun aparatlar ile bağlanarak siz balya yapmaya devam ederken o balyaları 8 li kümeler halinde araziye bırakır daha sonra telehandler-traktör v.s takılı yükleme ataçmanı ile de 8 li küme halinde istenilen araca 1 kişi ile yükleme veya arazide istifleme ve boşaltma yapılır.

Alp-04 Ceren Bale Collecting Machine and Installation Attachment has been produced at Turkey first and only by our company. The patented product provides great convenience in the collection of Bale. The machine that is very simple to use is connected to the rear of your bale machine with the appropriate apparatus and while you are making bales, it leaves the bales in the land in 8 bulks, then, with attached loading attachment as Telehandler-Tractor etc. it is made by 1 person with the required tools for loading to the vehicle or stacking and unloading into the land.

ALP-04 CEREN	Boy Length (cm)	En Width (cm)	Yükseklik Height (cm)	Ağırlık Weight (cm)
Toplama Makinesi / Bale Collecting Machine	315	258	110	680
Yükleme Ataçmanı / Installation Attachment	195	237	75	255



BALYA YÜKLEME ATAŞMANI / *BALE LOADING ATTACHMENT*



ALP-02 EM

KOMBİNE HUBUBAT EKİM MAKİNESİ /

THE COMBINE GRAINS PLANTING MACHINE



	Br	12'li	14'li	16'li	18'li	20'li	22'li	24'lü
Mibzerde Toplam Boy / Drills Total Height	L (mm)	2470	2754	3038	3322	3606	3890	4174
Makinede İş Boyu / Business Length Machine	L1(mm)	1704	1988	2272	2556	2840	3124	3408
Makinede Sandık Boyu / Chest Length Machine	L2 (mm)	1870	2154	2438	2722	3006	3290	3574
Makinede Toplam Genişlik / Total Width Machine	N (mm)	2920	2920	2930	2930	2930	2940	2940
Makinede Toplam Yükseklik / Total height Machine	H (mm)	1370	1370	1370	1370	1370	1370	1370
Makinede Disk Aralığı / Disc Interval Machine	mm	142	142	142	142	142	142	142
Gübre Sandığı Hacmi / Fertilizer Fund Volume	dm ³	142	169	191	213	235	257	279
Tohum Sandığı Hacmi / Seed Fund Volume	dm ³	248	286	324	362	400	438	476
Gübre Sandığı Kapasitesi / Fertilizer Fund Capacity	Kg	148	170	192	214	236	268	290
Toh. San. Kapasitesi (Buğday) / Capacity (Wheat)	Kg	200	230	260	290	320	350	380
Toh. San. Kapasitesi (Arpa) / Capacity (Barley)	Kg	160	185	210	235	260	285	310
Toh. San. Kapasitesi (Yulaf) / Capacity (Oats)	Kg	120	140	160	180	200	220	240
Toh. San. Kapasitesi (Mercimek) / Capacity (lentils)	Kg	225	260	295	330	365	400	435
Toh. San. Kapasitesi (Fasulye) / Capacity (Beans)	Kg	196	220	256	286	316	346	376
Toh. San. Kapasitesi (Nohut) / Capacity (chickpeas)	Kg	220	253	287	320	354	387	421
Makinede Net Ağırlık / Net Weight Machine	Kg	650	740	850	916	932	950	970
Toplam Gresörlük Sayısı / Total Number of Greaser	Adet	25	25	32	34	34	34	34
Çeki Oku Yerden Yüksekliği Ayarlanabilir / Read Czech Height-Adjustable Floor								
Disklerin Batma Derinliği / Depth of Disk = 0 – 150 mm Arası								
Mibzerde Kullanılan Teker / Wheels used drills = TR 68-6 Kat 650x16 veya 750x16								

Kombine tohum ekim mibzerimiz otomatik ve lifli olmak üzere iki tiptir.

Arpa, buğday, çavdar, yulaf, fiğ ve benzeri tahıl ürünlerini ve bir kısım bakliyatı mükemmel hassasiyetle ekebilir ve disk aralarındaki taban zinciri vastası ile ekim alanını örtme kabiliyetine sahiptir.

Mibzerimiz, gömücü ayaklarını yol ve iş durumuna getiren mekanik veya hidrolik kaldırma tertibatı sayesinde tohum ve gübreyi aynı sıraya istenilen miktarda ve derinlikte kesintisiz olarak toprağa bırakır.

12-14-16-18-20-22 ve 24 diskli çekili mekanik ve hidrolik sistemli askılı tip mibzerlerimiz mevcuttur.

*Combine seed drills, including two types of automatic and z fiber.
Barley, wheat, rye, oats, vetch and other cereals and some pulses may be the perfect addition to precision and has the ability to cover the planting area with the disc between the base chain means.
Our drills, embedding leaves the foot paths and job status that mechanical or hydraulic lifting device is solid thanks to seeds and fertilizers into the soil the same as the desired amount and depth.
12-14-16-18-20-22 and 24 mechanical and hydraulic disc towed our systematic strut type drills are available.*



Opsiyonel / Optional
11.5/80-15.3" Lastik / Tire

7.50-16" Lastik / Tire

6.50-16" Lastik / Tire



Pistonlu derinlik zinciri

The depth adjustment with piston



Boşaltma klapesi

Discharge flapv



Z dingil

Z axle



Sıyırıcılı disk

Scaper disc



Çelik döküm tohum-gübre kutusu

Steel casting grain-fertilizer box



Hidrolik bağlantı üç askı

Hydraulic connection of three hangers



Kilitli vana

Locked valve

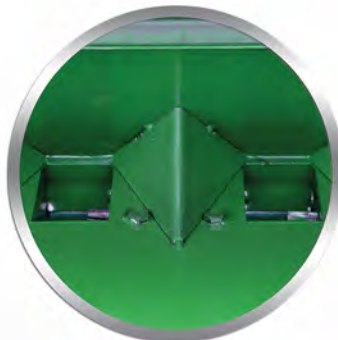

V sandık

V chest



Şeffaf tohum göstergesi

Transparent seed indicator

ALP-05 KAYAR ŞASE PNÖMATİK HASSAS EKİM MAKİNESİ / SLIDING FRAME PNEUMATIC PRECISION SEEDER



Mil Üzeri Kayar Şase
Chassis Sliding On Shaft



Alüminyum Gövde Şanzuman
Aluminium Body Gearbox



Yaylı Balta Sistemi
Leg Ax System



Dikey Gübre Gözü
Fertilizer Vertical Eye



Boşaltma Klepesi
Unloading Valves

ALP-05 Kayar Şase Pnömatik Hassas Ekim Makineleri her çeşit tohumun istenilen ekim aralığı ve sıra üzeri mesafesinde ekimini yapan çok yönlü makinelerdir. Hiçbir sökme ve takma yapmak zorunda kalmadan tek dokunuşla, birkaç dakikada ayarlayabileceğiniz ekim makinası ile istediğiniz sıra aralıklarına ekim yapabilirsiniz. Makinenizin sıra aralarını 45 cm' den 70 cm' ye veya ihtiyacınız olan tüm ölçülere ayarlayabilir, kızaklı şase sayesinde anında açık kapayabilirsiniz.

Mevcut baltalı ve diskli model ekim makinelerinin tüm özelliklerine sahip makineler istenirse gübre sistemli olarak kullanılabilir. ALP-05 Kayar Şase Pnömatik Hassas Ekim Makineleri 4-5-6-8 sıralı olarak imal edilebilmektedirler.

Uzun ömürlü hidrolik kumandalı şase kızakları sessiz ve titreşimsiz çalışırlar. İhtiyaca göre farklı aksesuarlar eklenilerek kullanılabilir. Yüksek çalışma hızı ve performansı ile zaman tasarrufu ve yüksek verim sağlar.

ALP-05 Kayar Şase Pnömatik Hassas Ekim Mibzeri, ihtiyaç olan miktarda gübre atabilir ve yüksek hacim kapasiteli gübre ve tohum depoları ile ara vermeden daha uzun süre ekim yapabilmektedir.

Lazer teknolojisiyle imal edilen ekici diskleri paslanmaz çelikten üretilmiştir.

Tekerlekten alınan hareketin ekici ünitelere iletilmesi şaft mekanizması ile sağlandığından daha hassas ekim yapılabilmektedir. Yapı ve konstrüksiyon bakımından imalatı standarttır.

ALP-05 Kayar Şase Pnömatik Hassas Ekim Mibzerleri beklentilere cevap veren kolay kullanıma sahip, sağlam ve kullanışlı makinalardır.

ALP-05 Sliding Chassis Pneumatic Precision Seed Drill engaged in all kinds of planting the seeds of the desired spacing and row spacing of planting and versatile machine. Without having to make any assembly and disassembly with a single tap, you can do as you wish with planting the seed drill intervals can be set in a few minutes. Search for your machine as 45 cm to 70 cm can be set to any size you need to or you can open and close instantly thanks to the sliding frame.

If the current ax and disc model with all the features of seeder machines can be used as fertilizer desired system. ALP-05 Sliding Chassis pneumatic precision sowing machines can be manufactured in sequence 4-5-6-8.

Long-lasting hydraulic control frame rails they run quietly and without vibration. eklenilerek different accessories can be used according to need. When the high operating speed and performance saving and high efficiency.

ALP-05 Sliding Chassis Pneumatic Precision Seed Drills, the amount of fertilizer that could need and is capable of high-capacity longer break from planting fertilizer and seed stores.

cultivator discs are manufactured by laser technology is manufactured from stainless steel.

be forwarded to the planter unit is provided with a motion from the wheel shaft mechanism can be made more precise planting. In terms of the structure of manufacturing and construction it is standard.

ALP-05 Sliding Chassis Pneumatic Precision Seed Drills are responding to expectations for ease of use, robust and convenient machine.



BALTALI TİP PNÖMATİK HASSAS EKİM MAKİNESİ / AX TYPE PNEUMATIC PRECISION SEEDER



ALP-PM	Uzunluk Length (cm)	Genişlik Width (cm)	Teorik İş Geniřlięi Work Width	Yükseklik Height (mm)	Aęırlık Weight (kg)	Koruyucu Boya Rengi Protective Paint Color
4 Ekici Üniteli / Planter Unit	2126	2800-4817	2100	1580	920	Kırmızı-Mavi / Red-Blue
5 Ekici Üniteli / Planter Unit	2126	2800-4817	1800	1580	1000	Kırmızı-Mavi / Red-Blue
6 Ekici Üniteli / Planter Unit	2126	3800-5967	3500	1580	1170	Kırmızı-Mavi / Red-Blue

Baltalı Tip Pnömatik Hassas Ekim Makinaları ile her tip tohum ekimi zorlu toprak koşullarında dahi yüksek hassasiyetle gerçekleştirilir. Minimum toprak işleme sonrasında yapılacak olan hassas ekim işlemi sayesinde modern tarım ile sizde tanışacaksınız.

Ekim ünitesi, hareket iletim şaftı ile tahrik edilir. Şaftlı tip tahrik sistemi ile sıra üstü mesafe her koşulda düzgünlüğünü korur.

Paralelogram bağlantı zorlu arazi koşulunda çalışma kolaylığı sağlarken, mükemmel tekleme özelliğiyle ekici düzen tohum sarfiyatınızı minimize eder.

Standart ekim derinliğini sağlayan çift diskli gömücü ayaklar ile zorlu tarla şartlarında dahi toprak tohum temasını sağlar. İç bükey V şeklinde yerleştirilmiş baskı tekerleri ile hassas ekim işlemi gerçekleştirilir.

Ax-type pneumatic every type of seed with precision sowing machines, precision seeding operations to be carried out after high precision planting gerçeleştirilir. minum soil processing under tough field conditions with modern agriculture will meet in the first. Sowing unit, it is driven by the movement of the transmission shaft. From the top row with the type of drive system with shaft retains the smoothness in all circumstances. Parallelogram connection challenging terrain in ease of operation minimizes your while consumption perfect misfire featuring seeder seed mini. Providing the standard sowing depth with double disc embedding feet, and in harsh field conditions that the soil seed contact internal concave printing wheels fitted with precision sowing operation is carried out in a V shape.





ELEMELİ SAVURMALI KOMBİNE HARMAN MAKİNESİ / KNOCKOUT COMBINED THRESHING MACHINE

Basit ayar ve kullanım, darbelerle dayanıklı çelik gövde, Mükemmel iş verimi, her marka traktörlerle mükemmel çalışma, sınırsız servis ve yedek parça garantisi, zamandan ve yakıttan tasarruf sağlar
Harman makinemiz şaftlı (PTO) ve kayışlı olmak üzere 2 sistem olup buğday, arpa, yulaf, çavdar ve bir kısım kasnak ve kayış değiştirme suretiyle nohut, mercimek, fiğ, fasulye, bakla, mısır, kimyon vs. tarım ürünlerini hasat eder. Bu işlemler için gerekli hareket iletimi, traktör kasağından kayış düzeni veya kuyruk milinden şaft ile elde edilir.
Harman makinemizdeki diğer bir üstün özellik ise Kombine Çuvallama sistemi ile çuvala veya römorka hasat olan tahılı ve bakliyatı yükleyebilmesidir.

Simple setup and operation, impact-resistant steel housing, excellent work efficiency, excellent to work with all brands of tractor, unlimited service and spare parts guarantee, time and save fuel blend our machine shaft (PTO) and belt including 2 system is wheat, barley, oats, rye and chickpeas by a pulley and belt replacement parts, lentils, vetch, beans, broad beans, corn, cumin, etc. necessary action transmission for the SUID and harvesting of agricultural products processing, tractors are getting the shaft from the strap layout or tail shaft pulley. Another outstanding feature of our Threshing machine cereal with sacks or trailer harvest combined Bagging system and can be installed pulses.

Toplam Uzunluk Total Length	Toplam Genişlik Overall Width	Toplam Yükseklik Total Height	Besleme Ağız Genişlik Feeding mouth width	Batör Parmak Sayısı Number of fingers	Lastik Ölçüsü Tire Size	Ağırlık Weight
3860 mm	2500 mm	2360 mm	1200 mm	44 Adet	600x16	1440 Kg.



DEPOLU MOBİL SİSTEM HARMAN MAKİNESİ ÇİFT BANTLI / MACHINE DUAL BAND MOBILE SYSTEMS

Depolu sistem makinemiz buğday, arpa, yulaf, çavdar ve bir kısım karnak ve kayış deęiřtirme sureti ile nohut, mercimek, fię, fasulye, bezelye ve bakla gibi tarım ürünlerini hasat eder. Bu işlemler için gerekli hareket traktör milinden şaftla özel dizayn edilmiş şanzıman vasıtası ile sağlanmaktadır.

Makinemiz üzerindeki tahıl deposu 1 ton tahıl depolayabilmektedir. İsterse depodaki tahılı boşaltmak için özel boşaltma sistemi veya teleskopik lift sistemi monte edilebilir. Eğimli arazide hidrolik lift teşkilatı sayesinde vakit kaybetmeden dengeli bir şekilde hasata devam edilir. Batör ayar sistemi ile istenilen incelikte ve kalınlıkta saman eldesi makinenin dięer bir avantajıdır.

Tank systems, our machine wheat, barley, oats, rye and some pulleys and belt replacement by with chickpeas, lentils, vetch, beans, peas and beans as they harvest their crops. This process is provided to the shaft specially designed gearbox means the necessary action tractor shaft. The machine has grain storage on the special drain system or telescopic lift system to empty the grain in storage if 1 ton of grain depolayabilmektedir. ist can be mounted. With the hydraulic lift force on the hill continue to be harvested in a balanced way without delay. Bat desired settings in tact with the system and the resulting thick straw is another advantage of the machine.

Toplam Uzunluk Total Length	Toplam Genişlik Overall Width	Toplam Yükseklik Total Height	Toplam Ağırlık Total Weight	Besleme Haznesi Feeding Unit	Batör Parmak Sayısı Number of Fingers Bators	Lastik Ölçüsü Tire Size	Depo Hacmi Tank Volume
6320 mm	2180 mm	2640 mm	1800-2200 mm	1200 mm	44 adet	7,50 x 16	835-1045 dm ³



ALPARSLAN

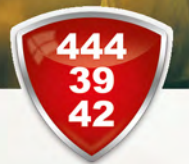

Alparslan Tarım Makinaları Sanayi ve Ticaret A.Ş.
Fabrika: 4. O.S.B. Büyükkayacık Mah. 406. Sok. No: 4 KONYA/TÜRKİYE
f: +90.332 248 2428 alparslan@alparslantarim.com

