

BIG KAISER



*3 SECOND QUICK TOOL CHANGE
ONE HEAD FOR DRILLING & TAPPING
REDUCES DOWNTIME AND ASSURES ACCURACY*

HIGH PERFORMANCE TOOLING SOLUTIONS

Drill Tapper

DRILL TAPPER

TAPPING RANGE: No. 8 - 2"

Quick-change system for drilling and tapping. Two operations with one head!

- Automatic torque limiter built into each Drill Tapper
- Built-in safety clutch and exclusive tap holders assure safe tapping
- No need to adjust torque for tapping blind or through holes
- Stable tapping is assured by simple but efficient cross tapping prevention system
- Excellent durability is achieved by utilizing the largest possible contact area
- Made with the finest quality material with a hardness of HRC 63, and ground clutch keys
- After long periods of use, the original torque can easily be restored by replacement of the clutch keys and torque rubbers

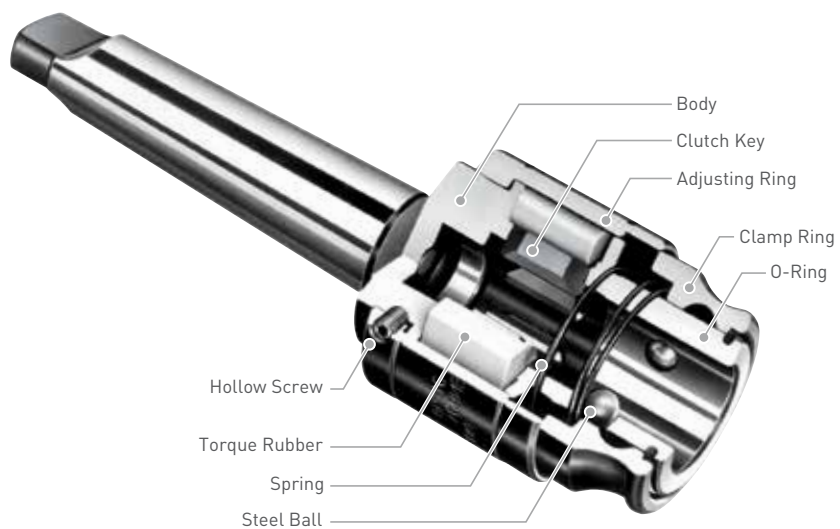
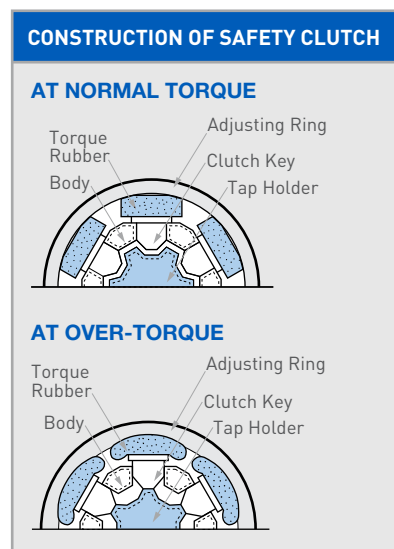

| Unified & American National Thread | | | | | | | | | ANPT, NPT & NPTP | | |
|------------------------------------|------|------|---------|-------|------|---------|-------|-------|------------------|-------|-------|
| Size | ød | E | Size | ød | E | Size | ød | E | Size | ød | E |
| NO.8 | .168 | .131 | AU9/16 | 0.429 | .322 | AU1.1/8 | .896 | .672 | AP1/8 | .438 | .328 |
| NO.10 | .194 | .152 | AU5/8 | .480 | .360 | AU1.1/4 | 1.021 | .766 | AP1/4 | .563 | .421 |
| NO.12 | .220 | .165 | AU11/16 | .542 | .406 | AU1.3/8 | 1.108 | .831 | AP3/8 | .700 | .531 |
| AU1/4 | .255 | .191 | AU3/4 | .590 | .442 | AU1.1/2 | 1.233 | .925 | AP1/2 | .688 | .515 |
| AU5/16 | .318 | .238 | AU13/16 | .652 | .482 | AU1.5/8 | 1.305 | .979 | AP3/4 | .906 | .679 |
| AU3/8 | .381 | .286 | AU7/8 | .697 | .523 | AU1.3/4 | 1.430 | 1.072 | AP1 | 1.125 | .843 |
| AU7/16 | .323 | .242 | AU15/16 | .760 | .570 | AU1.7/8 | 1.519 | 1.139 | AP1.1/4 | 1.313 | .984 |
| AU1/2 | .367 | .275 | AU1 | .800 | .600 | AU2 | 1.644 | 1.233 | AP1.1/2 | 1.500 | 1.125 |

ød=Diameter of shank E=Size of square

STANDARD SETS



| Catalog Number | Taper | Head | Holdings |
|---------------------|-------|------------|--|
| SDT24-2 ANSI | MT2 | DT24-2 | T24-No.10, 1/4, 5/16, 3/8, 7/16, 1/2, 9/16, J24-6 |
| -3 ANSI | MT3 | DT24-3 | T24-1/4, 5/16, 3/8, 1/2, 5/8, 3/4, 7/8, J24-6, D24-MT2 |
| -4 ANSI | MT4 | DT24-4 | |
| SDT33-4 ANSI | MT4 | DT33-4 | T33-3/8, 1/2, 5/8, 3/4, 7/8, 1, 1.1/4, J33-6, D33-MT3 |
| -5 ANSI | MT5 | DT33-5ANSI | |

- Sets do not include Drill Chuck
- MT5 Taper is provided with ANSI Standard Cotter Slots

HEAD

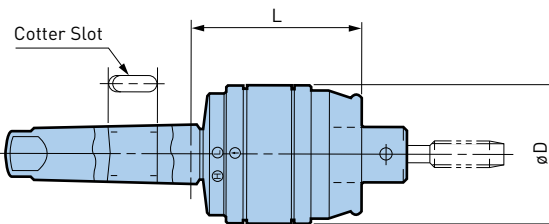

| Catalog Number | Taper | Tapping Range | | Drilling Capacity | D | L | Weight (lbs.) |
|-------------------|-------|---------------|-------------|-------------------|------|------|---------------|
| | | UNC | PT, PF | | | | |
| DT24-2 | MT2 | No.8 - 1/2 | 1/8 - 1/4 | .825 | 2.80 | 4.00 | 4.2 |
| -3 | MT3 | No.8 - 7/8 | 1/8 - 1/2 | 1.250 | | | 4.6 |
| -4 | MT4 | | | | | | 6.2 |
| DT33-4 | MT4 | 5/16 - 7/8 | 1/8/2001 | 2.000 | 3.46 | 4.50 | 8.8 |
| -5ANSI | MT5 | | | | | | 10.6 |
| DT52-5ANSI | MT | 7/8/2002 | 1/2 - 1 3/4 | 3.000 | 4.45 | 5.40 | 19.6 |

- MT2/3/4 taper are without cotter slots
- MT5 taper is provided with ANSI standard cotter slots

STANDARD TAP—SIDE LOCK SYSTEM HOLDERS

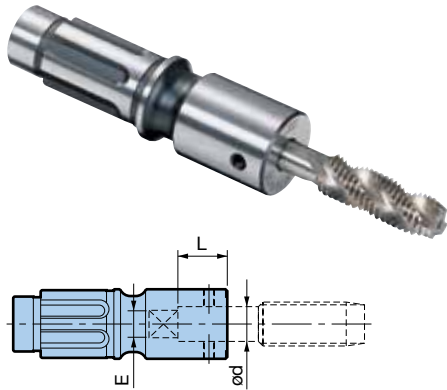

DT24

| Catalog Number | L |
|----------------|------|
| T24-NO.8 | .748 |
| -NO.10 | |
| -NO.12 | |
| -AU1/4 | |
| -AU5/16 | |
| -AU3/8 | .866 |
| -AU7/16 | |
| -AU1/2 | |
| -AU9/16 | |
| -AU5/8 | |
| -AU11/16 | .748 |
| -AU3/4 | |
| -AU13/16 | |
| -AU7/8 | |
| -AU15/16 | |
| -AP1/8 | .748 |
| -AP1/4 | |
| -AP3/8 | |
| -AP1/2 | |

DT33

| Catalog Number | L |
|----------------|------|
| T33-AU5/16 | .748 |
| -AU3/8 | |
| -AU7/16 | |
| -AU1/2 | |
| -AU9/16 | |
| -AU5/8 | .866 |
| -AU11/16 | |
| -AU3/4 | |
| -AU13/16 | |
| -AU7/8 | |
| -AU15/16 | .748 |
| -AU1 | |
| -AU1.1/8 | |
| -AU1.1/4 | |
| -AP1/8 | |
| -AP1/4 | .748 |
| -AP3/8 | |
| -AP1/2 | |
| -AP3/4 | |
| -AP1 | |

ACCESSORIES



STANDARD TAP—COLLET CHUCK SYSTEM HOLDERS

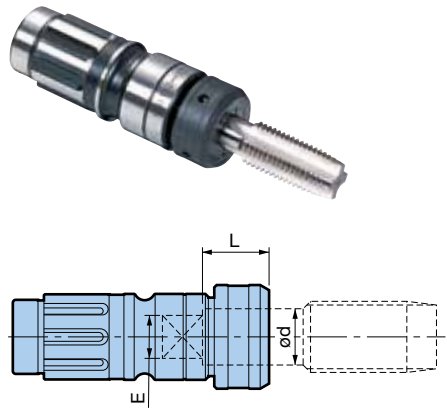

DT52

| Catalog Number | L |
|----------------|-------|
| T52-AU7/8 | 1.063 |
| -AU15/16 | |
| -AU1 | |
| -AU1.1/8 | 1.260 |
| -AU1.1/4 | |
| -AU1.3/8 | |
| -AU1.1/2 | 1.378 |
| -AU1.5/8 | |
| -AU1.3/4 | |
| -AU1.7/8 | 1.575 |
| -AU2 | |
| -AP3/8 | .906 |
| -AP1/2 | |
| -AP3/4 | .984 |
| -AP1 | .827 |
| -AP1.1/4 | .984 |
| -AP1.1/2 | 1.102 |

ACCESSORIES



DRILL CHUCK ADAPTER



| Catalog Number | Head |
|----------------|------|
| J24-6 | DT24 |
| J33-6 | DT33 |
| J52-6 | DT52 |

- Drill Chuck is not included JACOBS Taper JT6

MORSE TAPER ADAPTER



| Catalog Number | Head |
|------------------------|------|
| D24-MT1, MT2, MT3 | DT24 |
| D33-MT1, MT2, MT3, MT4 | DT33 |
| D52-MT2, MT3, MT4, MT5 | DT52 |

BIG KAISER Precision Tooling Inc.

A Member of the BIG DAISHOWA Group

2600 Huntington Blvd | Hoffman Estates, IL 60192 | P: (224) 770-2999 | F: (224) 770-2997 | bigkaiser@us.bigkaiser.com | www.bigkaiser.com

05/2018 © Copyright 2018 BIG KAISER