



● TELAIO A FILO DIAMANTATO

● FRAME WITH DIAMOND WIRE

● CADRE À FIL-DIAMANTÈ

● CORTADORA DE HILO DIAMANTADO

**MONOFIL BM**



**BM**



# MONOFIL BM 2300

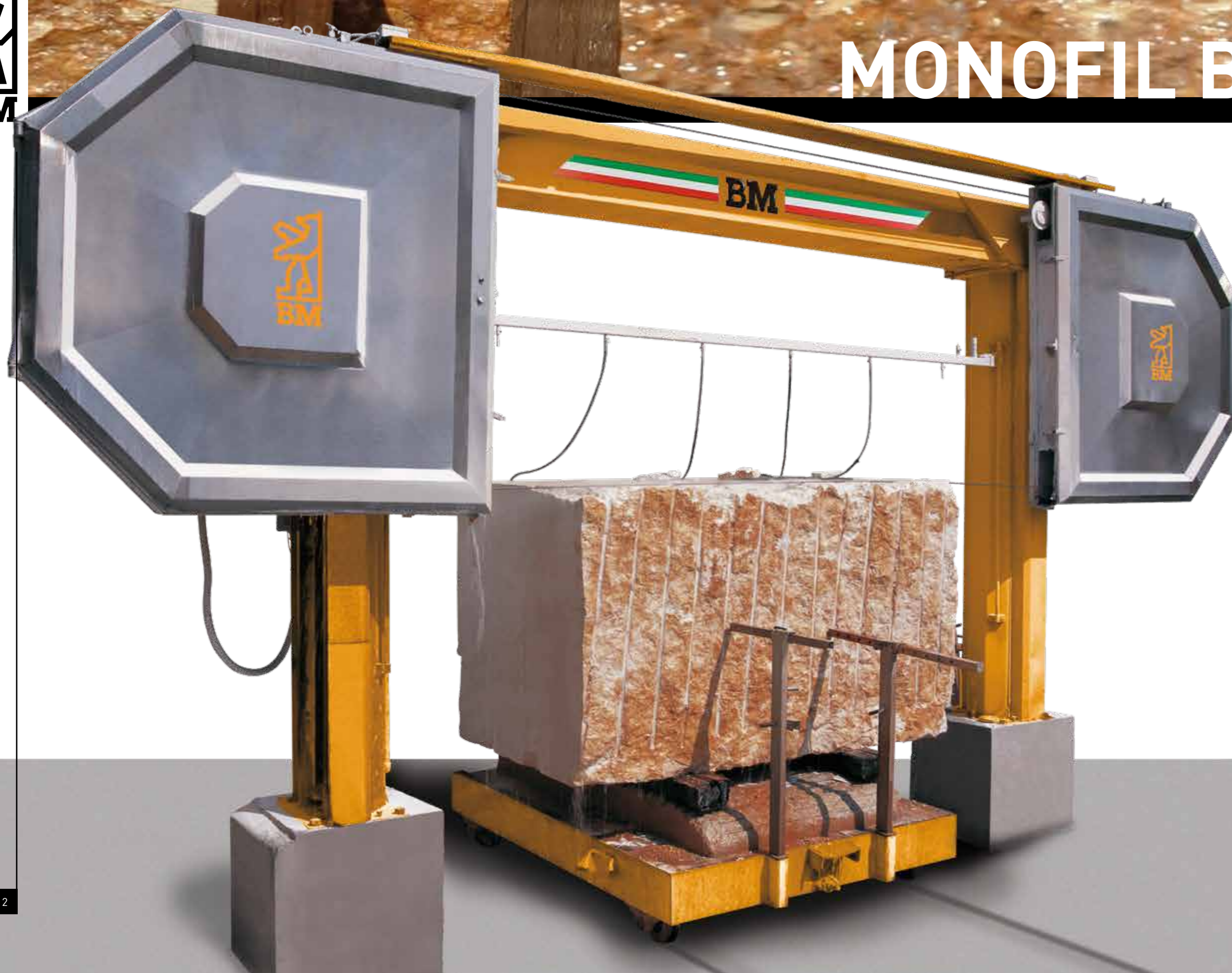

Telaio atto alla squadratura di blocchi di marmo o granito e taglio di grossi spessori.

Frame used to square off blocks of marble or granite and saw very thick blocks.

Cadre apte à l'équarrissage de blocs de marbre ou granit et à la coupe de grandes épaisseurs.

Cor tadora para escuadrar bloques de mármol o granito y cortar grandes grosores.

# MONOFIL BM 2300

# Caratteristiche Tecniche

Technical data • Características técnicas • Características técnicas

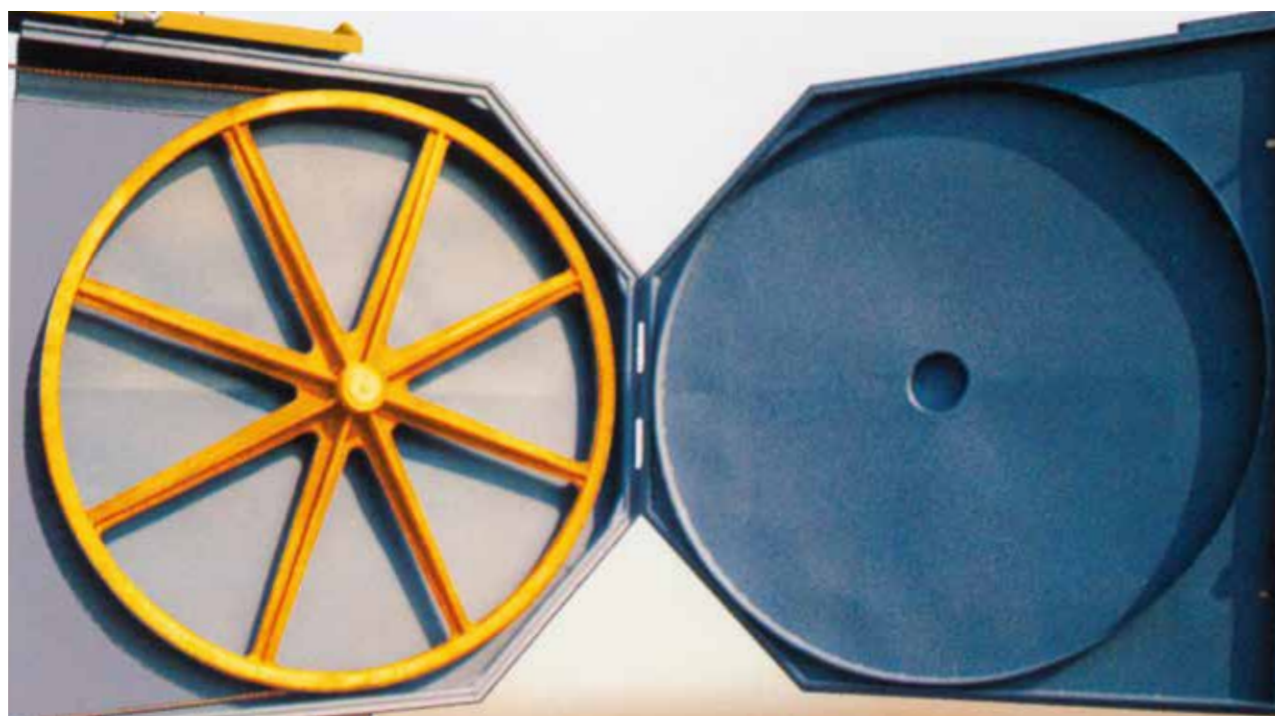

**VOLANO • FLYWHEEL • VOLANT • VOLANTE**

**Ø 2.300 MM**

Alle estremità si trovano due montanti in carpenteria sui quali scorrono i carrelli portavolani. Un motoriduttore fa ruotare i volani a una velocità fissa di 37 mt. al minuto o variabile da 5 a 37 mt. al minuto con inverter. Il tensionamento del filo avviene mediante un cilindro idraulico comandato da una centralina che, in caso di rottura del filo, arresta automaticamente la macchina.

On the sides there are two load-bearing uprights where the flywheel supports slide. A gear motor with inverter turns the flywheels at a constant speed of 37 metres per minute, or at a variable speed ranging from 5 to 37 metres per minute. The wire is tightened using a hydraulic cylinder managed by a control unit which, if the wire breaks, automatically stops the machine.

Aux extrémités, deux montants en charpente sont prévus sur lesquels glissent les chariots portevolants. Un motoréducteur avec invertisseur fait tourner les volants à une vitesse fixe de 37 mètres/minute ou variable de 5 à 37 mètres/minute. La mise sous tension du fil est effectuée par un cylindre hydraulique commandé par une centrale qui, en cas de rupture du fil, arrête automatiquement la machine.

En los extremos se hallan dos largueros de carpintería sobre los que se deslizan los carros portadiscos. Un motorreductor con inverter hace que los discos giren a una velocidad fija de 37 metros por minuto o variable de 5 a 37 metros por minuto. El tensado del hilo se efectúa con la ayuda de un cilindro hidráulico controlado por una centralita que, en caso de que el hilo se rompa, detiene automáticamente la máquina.

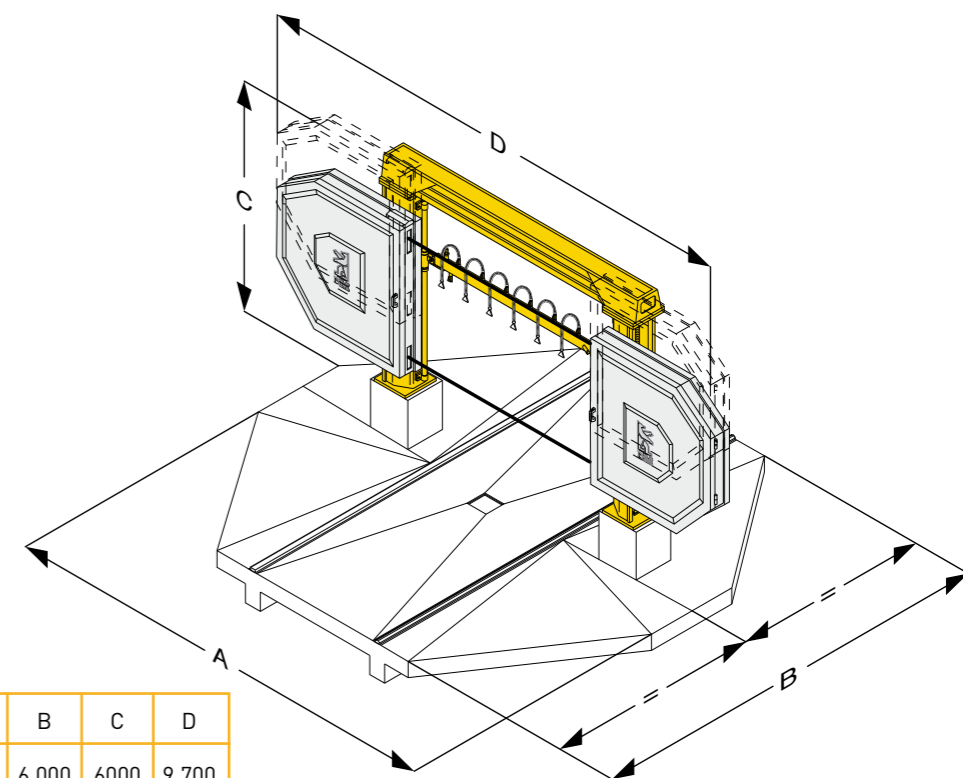

Modello	A	B	C	D
Standard	9.250	6.000	6000	9.700

	Taglio utile Useful cutting size Sciage utile Corte util		Potenza installata Installed power Puissance installée Potencia instalada		Velocità del filo Wire linear speed Vitesse du fil diamanté Velocidad filo						
Modello	Lunghezza filo Length of the diamond wire Longueur du fil-diamanté largo filo mm	Altezza Height Hauteur Alto mm	Larghezza Width Largeur Ancho mm	Principale Main Principal Principal Kw	Apparecchiatura cala rapida Fast lowering unit Appareillage de descente rapide Grupo bajada veloz Kw	Variable Variable Variable Variable mt./min.	Fisso Fixe Fijo Fijo mt./min.	Velocità cala lavoro Working lowering speed Vitesse de descente en travail Velocidad de bajada en trabajo mm	Peso macchina Weight of the frame Poids chassis Peso máquina Kg	Dim. carrello girevole Dimensions of turning trolley Dim. du chariot tournant Dim. carro rotatorio mm	Dim. carrello fisso Dim. of fixed bench trolley Dim. du chariot fixe Dim. carro fijo mm
<b>MONOFIL BM 2300 STANDARD</b>	21.000	2.200	4.000	25	4	5 ÷ 37	37	0 ÷ 2.000	9.700	2.300 x 2.300	3.000 x 2.300

\* Su richiesta della clientela le misure di taglio utile possono essere variate.  
\* The useful sawing dimensions can be varied upon request of the customer.  
\* Sur demande des clients, les mesures utiles de sciage peuvent être variées.  
\* Se puede modificar las medidas de corte.

Le illustrazioni e i dati tecnici sono indicativi. La Ditta si riserva di apportare qualsiasi modifica alle macchine, senza preavvisare il cliente. All technical data contained in this catalogue is subject to review and not binding. We reserve the right to modify all aspects of our machinery without prior notice to the customer. Les données techniques présentées dans ce catalogue sont fournies à titre indicatif et peuvent être modifiées sans préavis. Las ilustraciones y datos técnicos son indicativos. La firma se reserva el derecho de modificar la máquina, sin avisar previamente al cliente.

# MONOFIL BM 1000

## OPTIONALS

Optionals • Optionnelles • Opcionals

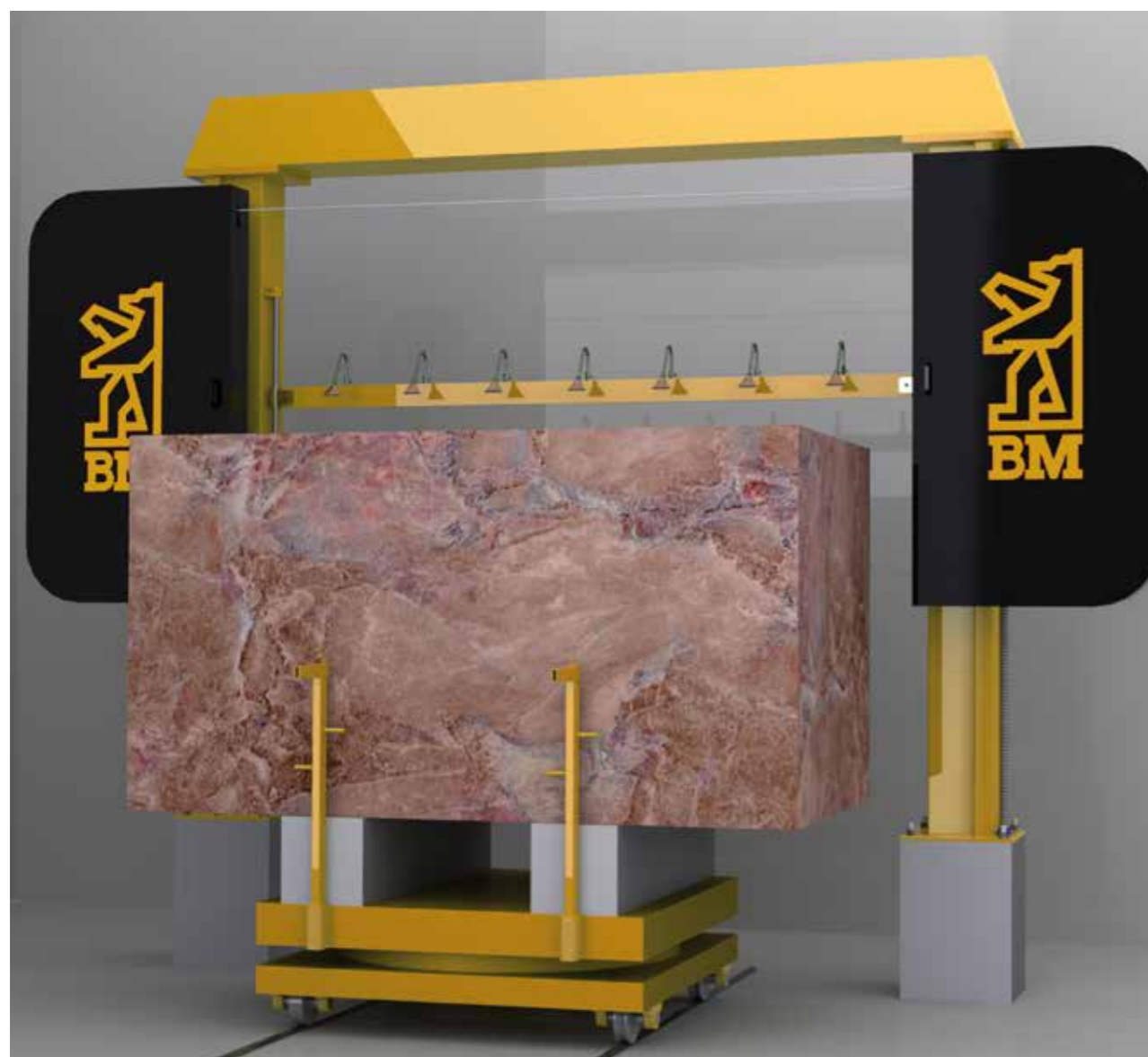

Telaio atto alla squadratura di blocchi di marmo o granito e taglio di grossi spessori.

Frame used to square off blocks of marble or granite and saw very thick blocks.

Cadre apte à l'équarrissage de blocs de marbre ou granit et à la coupe de grandes épaisseurs.

Cor tadora para escuadrar bloques de mármol o granito y cortar grandes grosores.

Programmatore automatico di taglio visualizzato su "touch screen" controllato da PLC.  
Automatic cutting programmer displayed on touchscreen, controlled by PLC.  
Programmeur automatique de coupe visualisée sur un « écran tactile » contrôlé par un PLC.  
Programador automático de corte visualizado en "pantalla táctil" controlada por PLC.



Inverter motore principale.  
Main motor inverter.  
Inverseur du moteur principal.  
Inversor del motor principal.

Carrello portablocchi girevole.  
Motorized rotating block trolley.  
Chariot porte-blocs tournant motorisé.  
Carro portabloques giratorio.



# MONOFIL BM 1000

# Caratteristiche Tecniche

Technical data • Características técnicas • Características técnicas

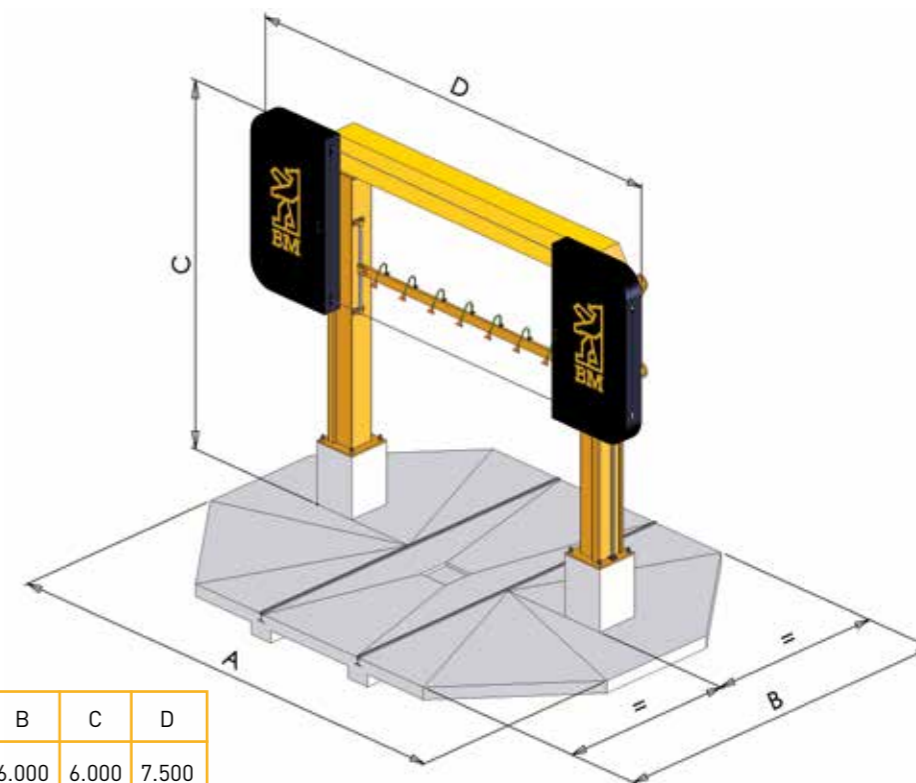
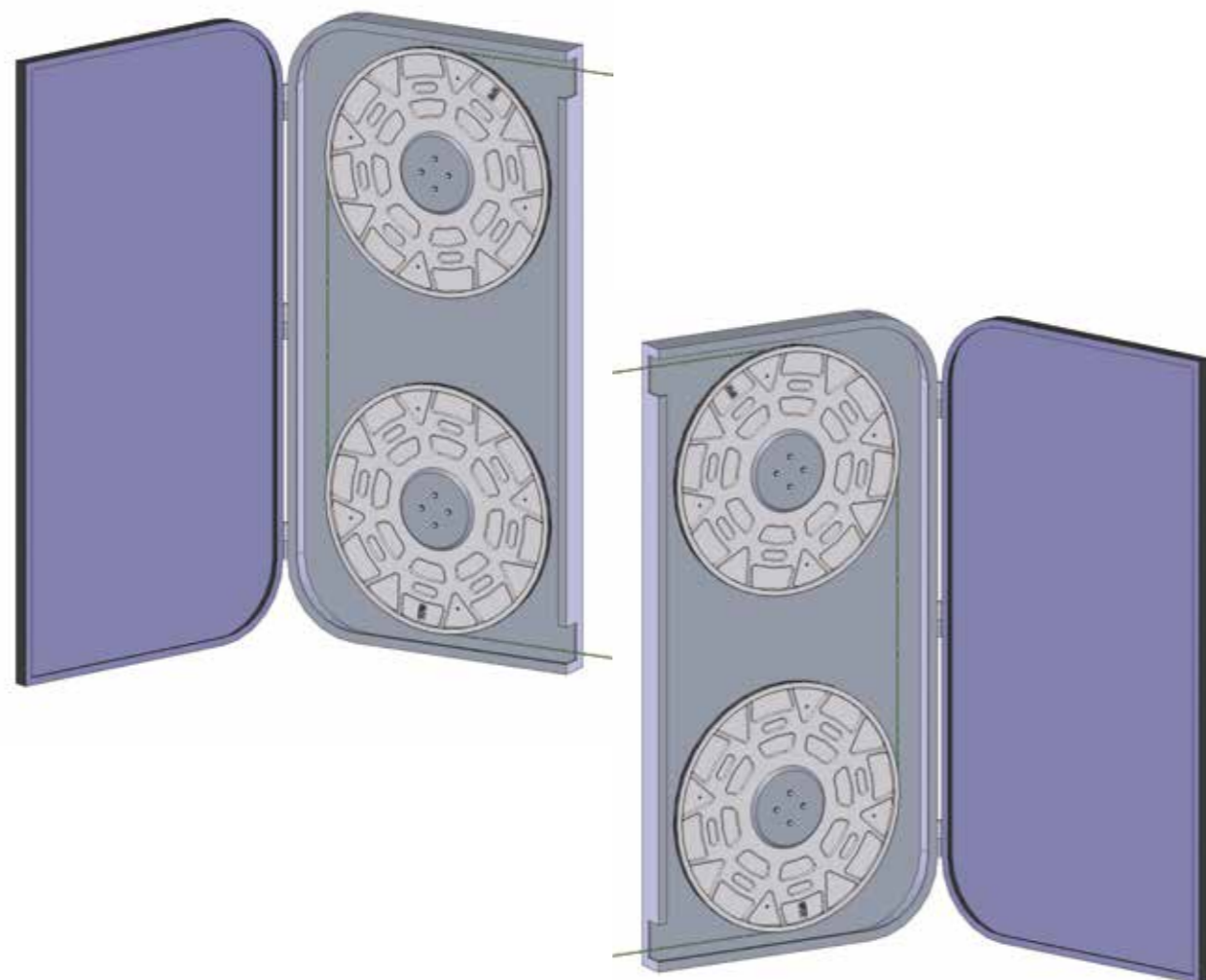

Modello	A	B	C	D
Standard	8.000	6.000	6.000	7.500

Modello	Taglio utile Useful cutting size Sciage utile Corte util		Potenza installata Installed power Puissance installée Potencia instalada		Velocità del filo Wire linear speed Vitesse du fil diamanté Velocidad filo		Velocità cala lavoro Working lowering speed Vitesse de descente en travail Velocidad de bajada en trabajo mm	Peso macchina Weight of the frame Poids chassis Peso máquina Kg	Dim. carrello girevole Dimensions of turning trolley Dim. du chariot tournant Dim. carro rotatorio mm	Dim. carrello fisso Dim. of fixed bench trolley Dim. du chariot fixe Dim. carro fijo mm
	Altezza Hateur Alto mm	Larghezza Width Largeur Ancho mm	Principale Main Principal Principal Kw	Apparecchiatura cala rapida Fast lowering unit Appareillage de descente rapide Gruppo bajada veloz Kw	Variabile Variable Variable Variable mt./min.	Fisso Fixed Fixe Fijo mt./min.				
<b>MONOFIL BM1000 STANDARD</b>	2.200	4.000	25	4	5 ÷ 37	37	0 ÷ 2.000	8.200	2.300 x 2.300	3.000 x 2.300

## VOLANO • FLYWHEEL • VOLANT • VOLANTE

Ø 1.000 MM

Vengono installate n.2 ruote in acciaio inox in ogni carrello portavolani, per un totale di 4 ruote.

N. 2 inox wheels are installed per each flywheel support.

N. 4 roues en acier inoxydable sont installés sur chaque porte dans les volants, pour un total de n. 4 roues.

Se instalados n. 2 ruedas de acero en cada carro portadiscos, para un total de 4 ruedas.

\* Su richiesta della clientela le misure di taglio utile possono essere variate.  
\* The useful sawing dimensions can be varied upon request of the customer.  
\* Sur demande des clients, les mesures utiles de sciage peuvent être variées.  
\* Se puede modificar las medidas de corte.

Le illustrazioni e i dati tecnici sono indicativi.  
La Ditta si riserva di apportare qualsiasi modifica alle macchine, senza preavvisare il cliente.  
All technical data contained in this catalogue is subject to review and not binding.  
We reserve the right to modify all aspects of our machinery without prior notice to the customer.  
Les données techniques présentées dans ce catalogue sont fournies à titre indicatif et peuvent être modifiées sans préavis.  
Las ilustraciones y datos técnicos son indicativos. La firma se reserva el derecho de modificar la máquina, sin avisar previamente al cliente.

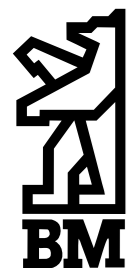

# BIFILO BM

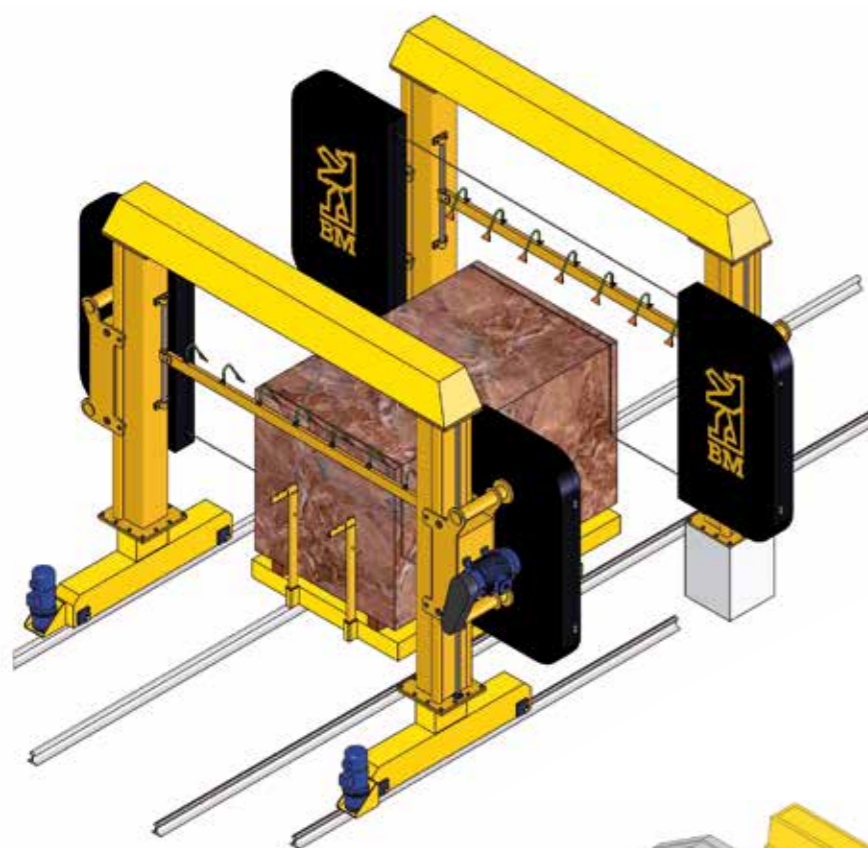

Bi-filo Monofil BM 1000/2300 con un telaio fisso più un telaio mobile su rotaie  
 Bi-wire Monofil BM 1000/2300 1 fix gangsaw + 1 mobil gangsaw on rails  
 Bi-fil Monofil BM 1000/2300 1 chassis fixes + 1 chassis mobil sur rails  
 Bi-filo Monofil BM 1000/2300 1 filo fixo + 1 filo movel em trilhos

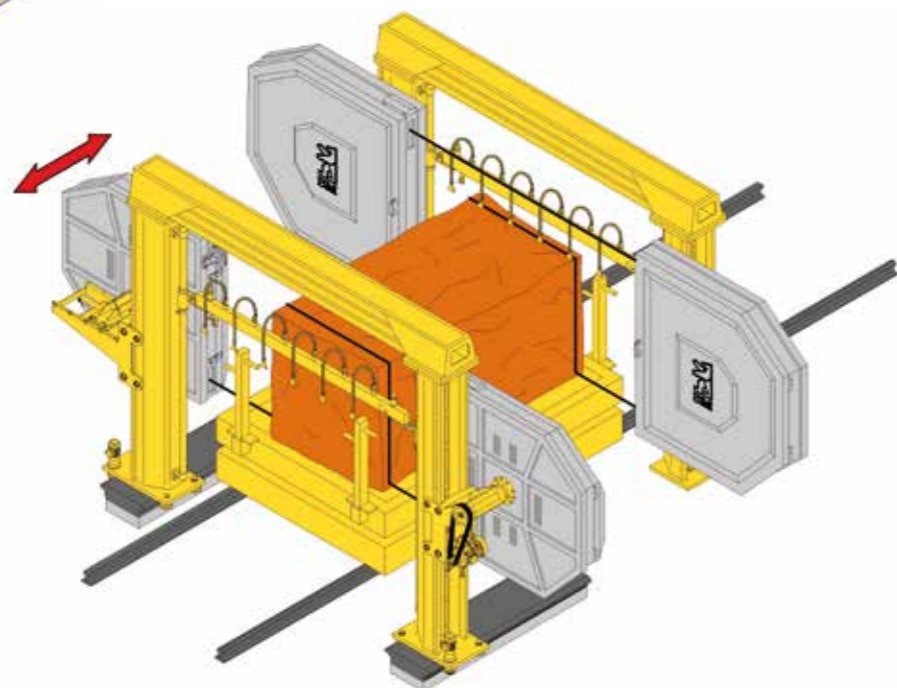

## TELAJ PER LA SEGAGIONE DEI BLOCCHI DI MARMO E GRANITO GANG SAW FOR SAWING MARBLE AND GRANITE BLOCKS

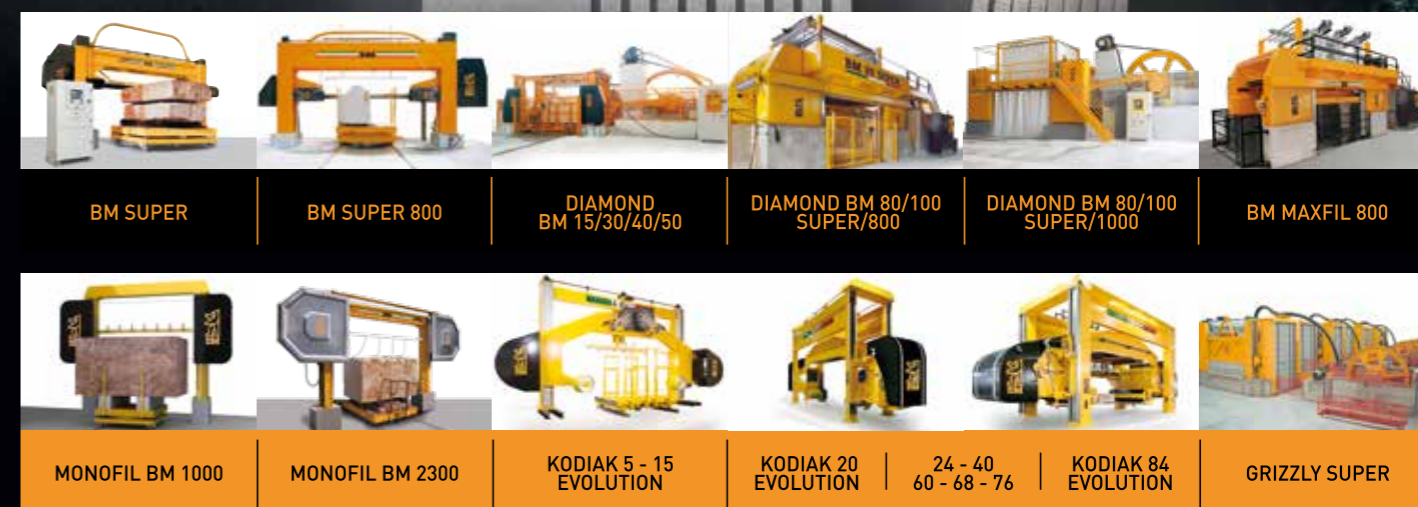



BM s.r.l. - Via 4 Novembre, 37  
Montorso Vicentino (Vicenza) - Italy  
Tel. +39 0444 485000 - Fax +39 0444 485085  
[www.bmofficine.it](http://www.bmofficine.it) - [bmofficine@bmofficine.it](mailto:bmofficine@bmofficine.it)