



CICORIA
— ITALY - 1927 —



CONVENTIONAL SQUARE BALERS

OPERATING WORLDWIDE



ENGLISH

ENGINEERED *and*
MADE IN ITALY

OUR SPECIALISATION

A manufacturing tradition started in 1927 and 50 years of specialisation in the industry of balers in four continents are the foundation of our success.

The result are balers of no compromise functionality for all latitudes coupled with

low operational baling costs.

Hay, straw, corn stalks, sorghum, and all crop residues are pressed and perfectly binded with twine or iron, in every hour of the day, even with extreme temperatures and humidity level.

OUR INDUSTRIAL SETTLEMENT

Our story begun and continues still today in Italy, in the Basilicata region, a few kilometres from the Melfi automotive centre (FCA). A territory full of a tradition characterised by a strong agricultural vocation and a considerable production of high quality cereals and straw. Here Cicoria engineers and produces square

balers at the forefront of the technology. **This territory, thanks to a particularly hot climate and uneven terrains, often with clay and stones, offers ideal operative conditions to severely test all our products, in order to win always new challenges worldwide.**





CICORIA
— ITALY - 1927 —

OUR WORLDWIDE PRESENCE

Four continents and more than 50 countries worldwide have chosen our pick-up balers. A great reward by the demanding

national and international markets to the special technological qualities of our products.



INTERNATIONAL COMPETENCE

ALBANIA, ALGERIA, ARGENTINA, AZERBAIJAN, BAHRAIN, BANGLADESH, BOLIVIA, BULGARIA, BURKINA FASO, CHILE, CHINA, COLOMBIA, CONGO, COSTA RICA, CROATIA, EGYPT, GREECE, HONG KONG, IRAQ, IRAN, ITALY, JORDAN, KENYA, KOREA, KUWAIT, LIBYA, MALAYSIA, MALTA, MOROCCO,

MEXICO, MOLDAVIA, NICARAGUA, PAKISTAN, POLAND, PORTUGAL, ROMANIA, RUSSIAN FEDERATION, SAUDI ARABIA, SPAIN, SUDAN, SYRIA, TAIWAN, TANZANIA, THAILAND, TUNISIA, TURKEY, TURKMENISTAN, UNITED ARAB EMIRATES, UKRAINE, URUGUAY, UZBEKISTAN, VENEZUELA.





CICORIA
— ITALY - 1927 —



A CERTIFIED TECHNICAL REPUTATION

Simple functionality, high performances, reliability in the intensive use, high commercial value over time.

Four characteristics that our numerous clients worldwide recognise as specific of our products, due to the extraordinary

structural quality and the continuous technological upgrade of the most important features, such as the extra long piston stroke, the wide feeding opening and the proven binding kit.



CICORIA
— ITALY - 1927 —

FEATURES OF THE MACHINE

FRONT SIDE

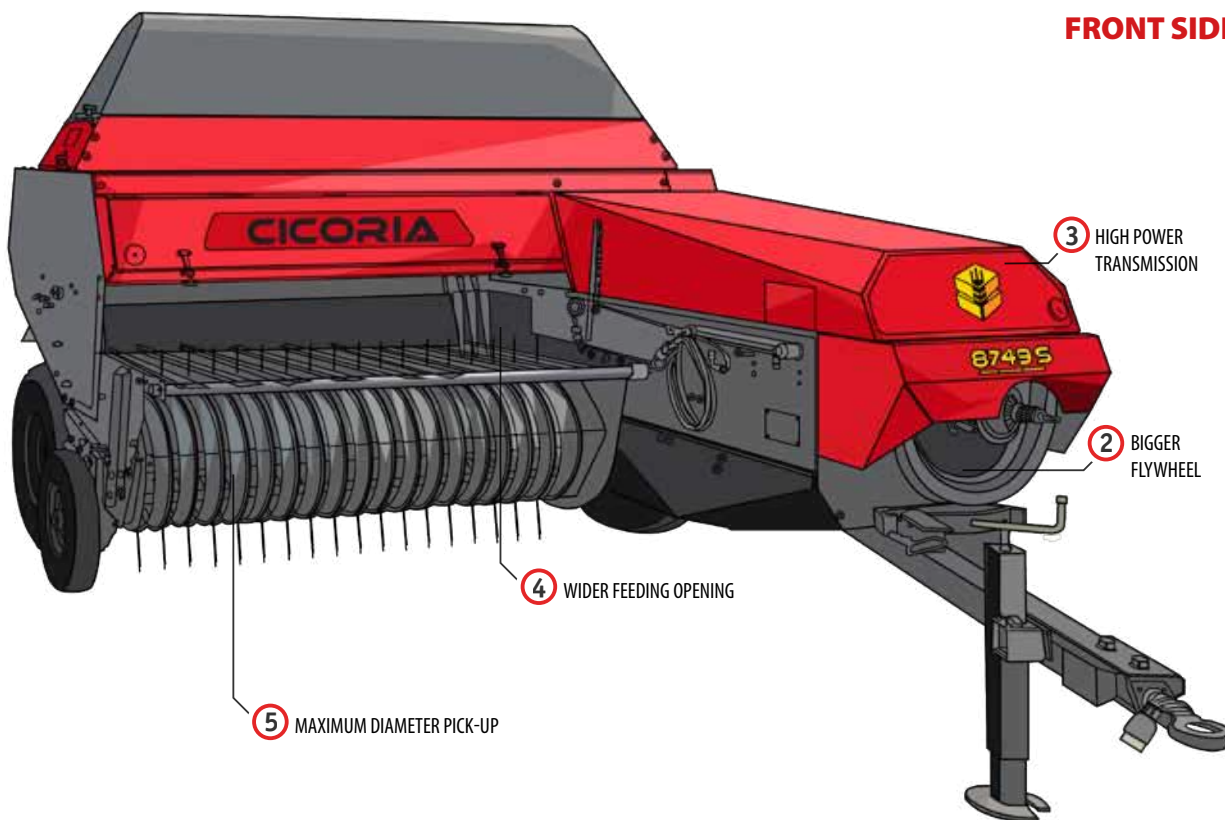

BACK SIDE

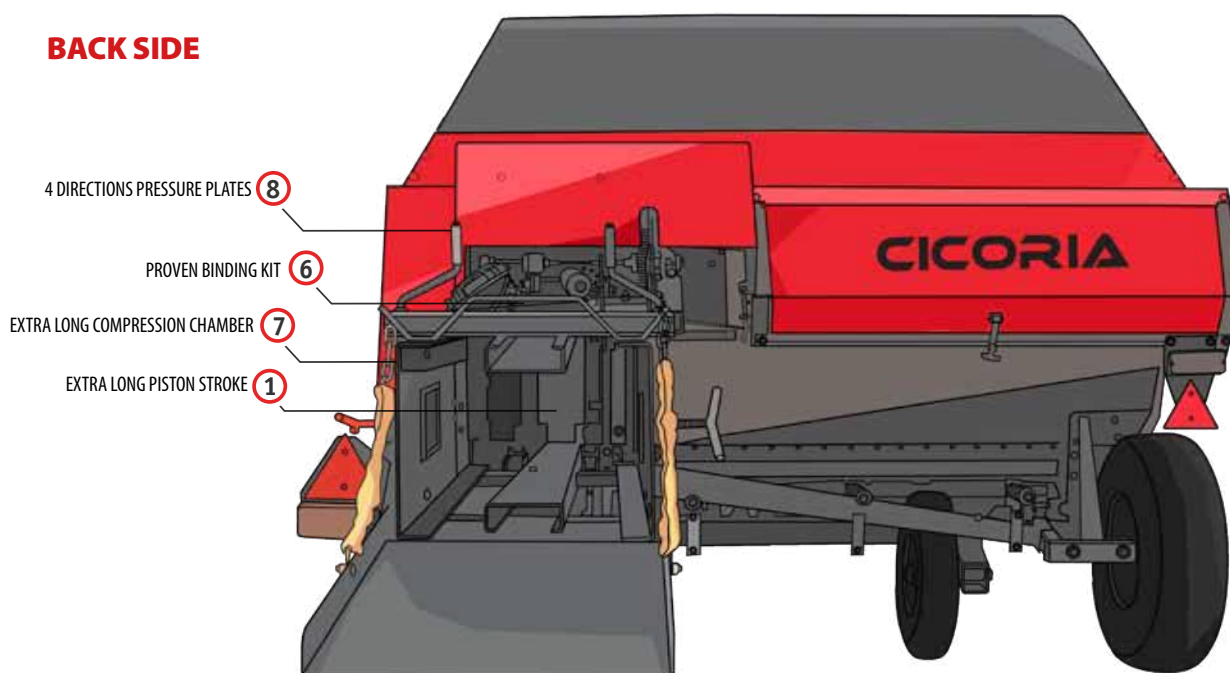



CICORIA
— ITALY - 1927 —

THE COMPRESSION COMPONENTS POWERFUL AND RELIABLE

EXTRA LONG PISTON STROKE

A functional characteristic which increases the efficacy of the piston, allowing a strong compression and a better control of the straw

pressure on the twines, to the advantages of weight increase and the perfect binding of the bales.

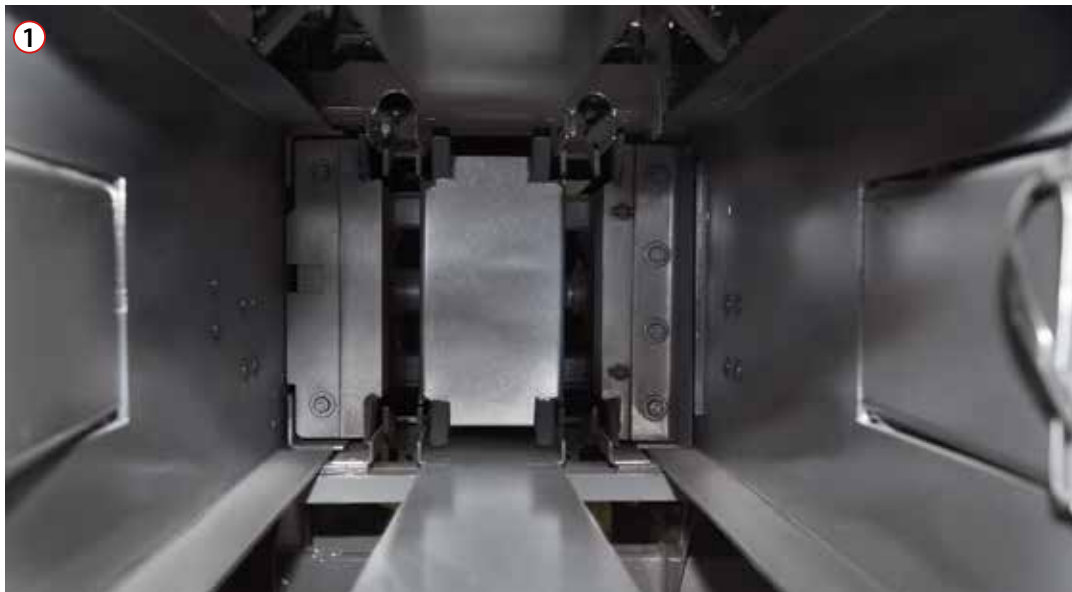

BIGGER FLYWHEEL

A technical solution which strenghtens the action of the flywheel, allowing a fast and flowing harvest, even in presence of irregular

windrows and accumulations of product, thanks to the high inertial momentum generated by the bigger flywheel.





CICORIA
— ITALY - 1927 —

HIGH POWER TRANSMISSION

High resistance gearbox, oversize bevel gear, big dimensional counterweight crank. A system of high efficiency able to push over to the

piston an extraordinary thrust, assuring safety of use, high baling speed and high density of the product.





CICORIA
— ITALY - 1927 —

FEEDING UNITS HIGH OPERATIVE CAPACITY

WIDE FEEDING OPENING

Higher productivity means to harvest the product in the best moment. With the new extra wide feeding opening performances

are increased by 20%, thanks to the bigger quantity of product that forks can force into the compression chamber.



MAXIMUM DIAMETER PICK-UP

A pick-up designed with the maximum allowed diameter in order to lead a considerable and uniform flow of product into the compression chamber and at the same time reduce the risk of external objects from entering into the

chamber. A choice that shows all its advantages in the increase of performances, a superior cleanliness of the product, then a higher value of the harvest.





CICORIA
— ITALY - 1927 —

THE BINDING UNITS **CERTAINTY AND IMPECCABLE PRECISION**

PROVEN BINDING KIT

A high-technological system sponsored by farmers, in over 50 countries worldwide, thanks to extraordinary capability in binding without mistake under any condition.

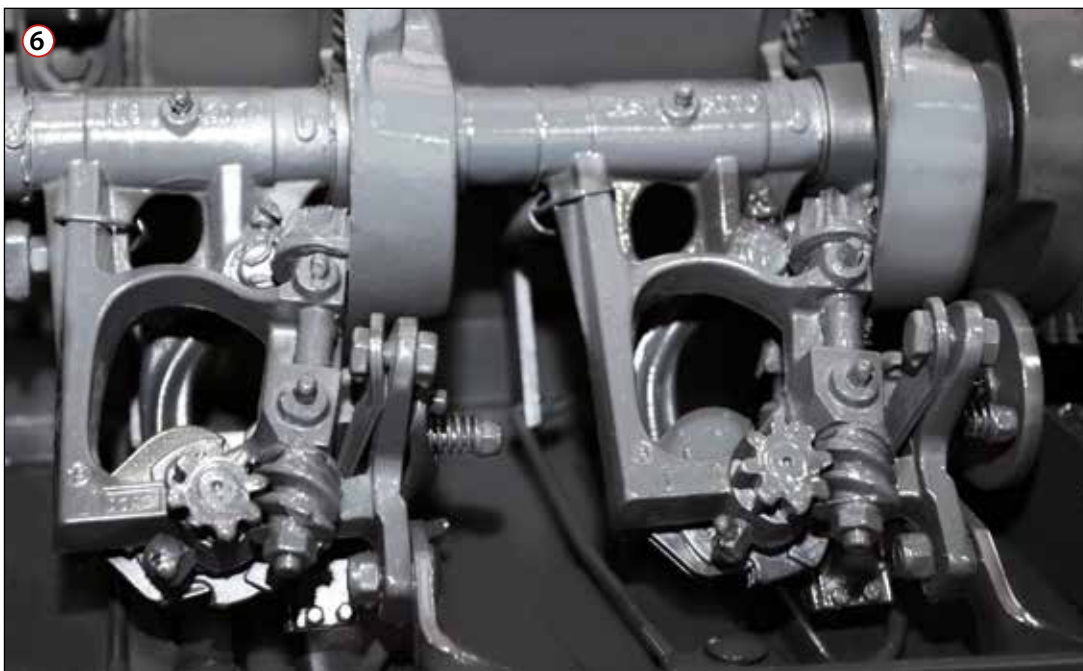

THE DENSITY AND UNIFORMITY UNITS PRESSURE FOR EVERY NEED

EXTRA LONG CHAMBER

An effective solution that further increases the pressure inside the compression chamber, compressing the product to obtain maximum uniformity and the density level specific for every need.



4 DIRECTIONS PRESSURE PLATES



A simple way to control the pressure, which allows to have the uniformity and the density of the product suitable for animal feeding or to obtain heavy bales needed for transport and trade.





CICORIA
— ITALY - 1927 —

SPECIAL CUT

HIGH PERFORMANCE CYLINDER

Pick-up balers model TP, with two or three knotters, are equipped with a special cutting and crushing unit that reduces the straw up to 3 cm

before baling.

An ideal length for animal feeding and to obtain heavy bales up to 50 kg.

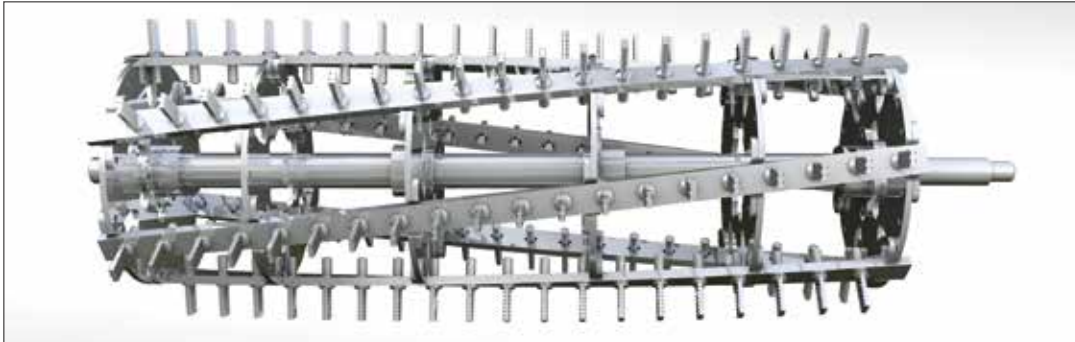

**HEAVY BALES
UP TO 50 KG**



**SHORT STRAW
UP TO 3 CM**



2 OR 3 RELIABLE KNOTTERS



OPTIONALS



WIDE ANGLE CARDAN SHAFT

Moving in narrow areas, head out on particular working angles. This is possible by adopting the wide angle cardan shaft, **which assures the power of the transmission in working angles up to 80° for brief periods and up to 25° continuously.**



TOWING EYE

A necessary optional that **avoids the torsion stress of the bar on the hook of the tractor**, allowing the baler and the tractor to adapt independently to the unevenness of the field.



HYDRAULIC PICK-UP LIFT

Quickly harvesting the product is crucial while working with uncertain weather conditions. The hydraulic pick-up **allows easily to overcome obstacles in front of pick-up and facilitates the harvest of the product in the field.**



PICK-UP SIDE WHEEL

To keep the pick up in the working position while working in an uneven field, this is the main task of the pick-up side wheel. The pick-up faces the instability of the field, avoiding guard tines and springs bumping the ground.



FAN KNOTTER CLEANING UNIT

A powerful device that **assures a complete cleanness of the binding system area**, removing heaps of dust and husk, even under the most hard working conditions.



THIRD CENTRAL WHEEL

Working with a balanced distribution in uneven fields. This is the task of the third central wheel, which **avoids the dip of the machine when there are obstacles, such as holes, ditches and others, with an optimal distribution of the weight on the ground.**



HYDRAULIC MOWING DRAWBAR

In a highly competitive sector the moving speed and the quick return to work are critical factors. Thanks to the hydraulic moving **the drawbar is quickly moved from the working to the transport position.**



KIT FOR SORGHUM AND MAIZE STALKS PICK-UP

An ideal optional to harvest smoothly and without loss voluminous, stiff, with high specific weight products, such as maize and sorghum stalks. **Thanks to this kit it is easy to produce very dense bales at high speed also for such difficult products.**



WORK LIGHT

Working at night like in the daytime, thanks to the swiveling 360° work light. The operator can **monitor the binding phase and the formation of the bale for a quick intervention by necessity.**



PNEUMATIC PRESSER WITH INFRARED CAMERA

An effective device, adjustable directly by the driver's seat, which allows quickly to set the pressure in the compression chamber, in order **to obtain a fixed density of the product in every working conditions.**



LOADING CHUTE WITH DRAWBAR

Clear the field off of bales immediately, speed the harvest for the sale, quicken the storage. The loading chute with drawbar **eases these operations, moving quickly bales from the compression chamber to the trailer, with a considerable saving of time.**

WIDE RANGE



A numerous family of **16 models**, one for each necessity, projected to work in both small and wide fields, by farmers and baling professionals.

TECHNICAL FEATURES

Series	Model	Knotters		Chamber	Bales Size		Piston	
		N.	TYING MATERIAL TYPE	SECTION CM	ADJUSTABLE LENGTH CM	WEIGHT KG	STROKE LENGTH CM	STROKES/MINUTE AT 540 RPM N.
SMALL	2545 S	2	Twine	35 x 47	40 -130	18 - 30	71	90
SMALL	2545 F	2	Wire	35 x 47	40 -130	18 - 30	71	90
STANDARD	2547 S	2	Twine	35 x 47	40 -130	18 - 30	71	90
STANDARD	2547 F	2	Wire	35 x 47	40 -130	18 - 30	71	90
PROFESSIONAL	2747 S	2	Twine	37 x 47	40 - 130	24 - 48	75	90
PROFESSIONAL	2747 F	2	Wire	37 x 47	40 - 130	24 - 48	75	90
PROFESSIONAL	2749 S	2/3	Twine	37 x 49	40 - 130	25 - 50	75	90
PROFESSIONAL	2749 F	2	Wire	37 x 49	40 - 130	25 - 50	75	90
TOP	8747 S	2	Twine	37 x 47	40 - 130	24 - 48	75	90
TOP	8747 F	2	Wire	37 x 47	40 - 130	24 - 48	75	90
TOP	8749 S	2/3	Twine	37 x 49	40 - 130	25 - 50	75	90
TOP	8749 F	2	Wire	37 x 49	40 - 130	25 - 50	75	90
TOP L	888 S	2/3	Twine	37 x 49	40 - 130	25 - 50	75	90
TOP L	888 F	2	Wire	37 x 49	40 - 130	25 - 50	75	90
TRINCIA PAGLIA	TP 2747 S2	2	Twine	37 x 47	40 - 130	24 - 48	75	90
TRINCIA PAGLIA	TP 2749 S3	3	Twine	37 x 49	40 - 130	25 - 50	75	90

DATA AND DESIGN WITHOUT OBLIGATION



CICORIA
— ITALY - 1927 —

SIDE VIEW

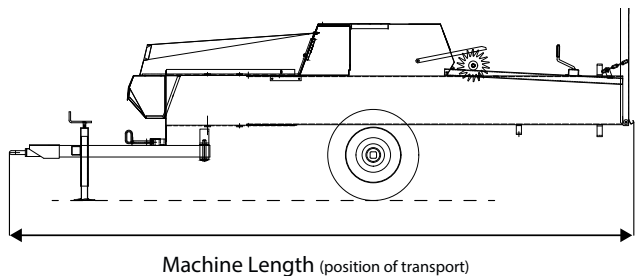

FRONT VIEW

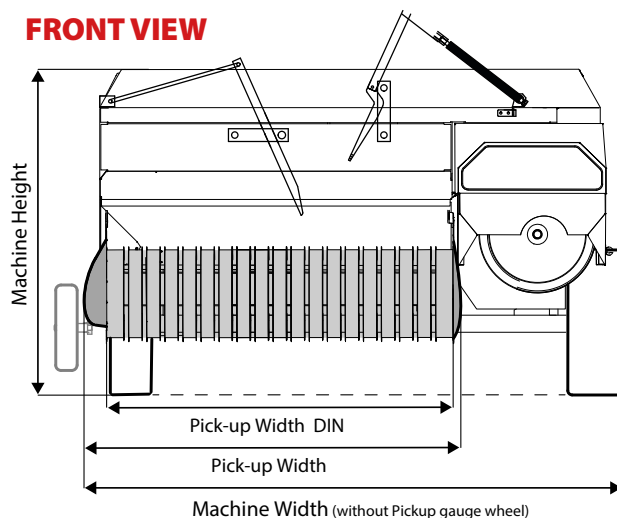

Pick-up				Forks	Feeding	Dimensions				Tractor requirements	
WIDTH	WIDTH DIN	TINE BARS	TINES	FRONT/BACK	OPENING	LENGTH	WIDTH	HEIGHT	WEIGHT	MINIMUM PTO POWER	PTO SPEED
CM	CM	N.	N.	N.	CMQ	CM	CM	CM	KG	KW/HP	RPM
140	128	4	56	1/1	1640	443	221	153	1200	22/30	540
140	128	4	56	1/1	1640	443	221	153	1240	22/30	540
160	145	4	64	1/1	1640	443	238	153	1250	25/34	540
160	145	4	64	1/1	1640	443	238	153	1290	25/34	540
160	145	4	64	1/1	1850	487	240	156	1375	29/39	540
160	145	4	64	1/1	1850	487	240	156	1425	29/39	540
160	145	4	64	1/1	1850	487	240	156	1450	33/44	540
160	145	4	64	1/1	1850	487	240	156	1500	33/44	540
180	162	5	90	1/1	1850	487	257	156	1500	37/50	540
180	162	5	90	1/1	1850	487	257	156	1550	37/50	540
180	162	5	90	1/1	1850	487	257	156	1575	40/54	540
180	162	5	90	1/1	1850	487	257	156	1625	40/54	540
205	190	5	110	1/2	1850	487	286	156	1670	44/59	540
205	190	5	110	1/2	1850	487	286	156	1745	44/59	540
160	145	4	64	1/1	1850	487	260	156	2000	50/68	540
160	145	4	64	1/1	1850	487	260	156	2050	50/68	540



CICORIA

SQUARE BALERS

CICORIA srl

S.S.168 Km 30,100
85026 Palazzo San Gervasio (PZ) Italia

Phone +39 0972 45131

Fax +39 0972 45132

E-mail info@cicoria.it

www.cicoria.it