



High-End Thermoforming for Vehicle Construction



INNOVATIONS THAT SHAPE THE WORLD OF PLASTICS.



THERMOFORMED PARTS – IDEAL FOR VEHICLE CONSTRUCTION

Moulded thermoformed parts made of plastic are playing an increasingly important role in vehicle construction. Compared to many other process technologies, the costs for moulds are significantly lower, and the simple and quick adaptability of the tools allows maximum flexibility in development. Thanks to high-performance plastics, the moulded parts are very light and the through-dyed plastics do not need to be painted, which saves costs and the environment. There are also many options for thermoformed plastic parts in terms of surface variety: For example, the colour scheme for the parts is freely selectable. Both vehicle exterior parts and interior parts can have matte surfaces, and exterior parts can also be produced with a high-gloss or metallic look. Vehicle interior parts can also be made with laminated fabric

or with soft-touch feel. Moulded parts produced using the twin-sheet process make it possible to achieve exceptional stability as well as different shapes on both sides.

One of the many strengths of the thermoforming process is its high cost-effectiveness in small batches. DUROtherm has also succeeded in producing 20,000 parts in serial production economically. Whether small series or large series – with over 50 years of know-how in thermoforming, DUROtherm is your ideal full-service partner for moulded parts for vehicle construction. Consulting and planning, development and design, prototyping and series production as well as logistics – all services come from a single source at DUROtherm.

THE BENEFITS AT A GLANCE

- Low tool costs
- Fast development and manufacturing times for the tools, and simple and cost-effective changes
- Short reaction times with fast changing design and model cycles
- Even zero series can be produced via cheap prototype tools
- Series tools are hardly subject to wear; even quantities up to 20,000 moulded parts can be produced
- Even huge mould sizes can be produced inexpensively
- Through-coloured plastics available in all colours; no painting required.
- High-quality design surfaces with excellent UV protection, in matte, high gloss or metallic optics feasible
- Injection-moulded optics possible through etched tools
- Exact design corners and edges can be realised
- Two-sided, with different shapes possible
- Low weight, high stability
- 100 % recyclable

THE OPTIMUM PROCESS ACCORDING TO REQUIREMENTS

Depending on the requirements and the desired condition with regard to shape and appearance, the thermoformed parts are deformed either positively or negatively.

In positive deformation, the tool is located at the bottom of the plastic sheet to be deformed. The sheet is pulled over the tool so that the visible side does not come into contact with it. High-gloss or metallic surfaces can be produced with excellent brilliance. Grooves are defined by the positive deformation.

mation of the plates and are available in a large selection. Although the radii are determined by the sheet thickness, they can still be shaped.

In negative deformation, the plastic sheet is pulled into the mould. This produces the visible side of the tool fitting side, which can have very fine radii, detailed edge curves and strong undercuts. In addition, a precisely defined surface can be etched directly into the tool so moulded parts can be produced with perfect injection-moulded optics.



Shaped radii with positive deformation; the material thickness defines the radii



Exact and detailed edges with negative deformation; applications optimally integrable



Positive deformation with applications, grains integrated directly into the sheet material



Negative deformation allows a freely definable surface structure and perfect injection-moulded look



Through-coloured plastics in freely selectable colours, also in metallic optics with positive deformation



Strong undercuts easily realisable thanks to negative deformation

POSITIVELY DEFORMED BODY PARTS – HIGH GLOSS AND SHAPED



Vacuum moulded parts with shaped radii, thanks to through-coloured plastics without painting and with high-gloss surfaces: DUROtherm also produces these positively deformed exterior parts for the Streetscooter. Accurate matching clearances round off the functional body

design of this electric van. The attachment mimics, which are mounted in the large assembly department at DUROtherm, and allow the moulded parts to be easily attached to the vehicle, are already firmly integrated in the delivery of the moulded parts.





Front grill



Left fender



Right fender



Mirror triangle



Engine bonnet



Door panel (front and rear view)



Cover B-pillar



Outer roof skin

POSITIVELY DEFORMED INTERIOR PARTS – FUNCTIONAL AND ELEGANT



The thermoforming process, which was deliberately chosen for this vehicle, also shows its strengths in the interior parts of this electric car. Because it enables the shortest development times with low mould costs and also adjustments that result in the course of the development process, projects can be carried out easily in a manageable budget. The internal

parts are positively deformed by DUROtherm. So the aesthetically pleasing graining is defined directly by the surface structure of the plastic sheet and, although the radii result from the sheet thickness, they integrate perfectly into the shaped interior design.





Dashboard cover



Door trim



Centre console



Boot lining side



Boot lining back

NEGATIVELY DEFORMED INTERIOR PARTS – FINE EDGES AND INJECTION MOULDING



Thermoformed parts with delicate edgings and the finest optics – that is how the numerous interior parts made by DUROtherm impress customers in the VW California. The strengths of the negative deformation shine: the grain structure is etched directly into the mould, which allows

the parts to achieve their excellent injection-moulded appearance. From pre-integrated loudspeakers to the prepared belt holder, the parts are delivered pre-assembled and can be fastened directly to the vehicle via concealed mounting elements.



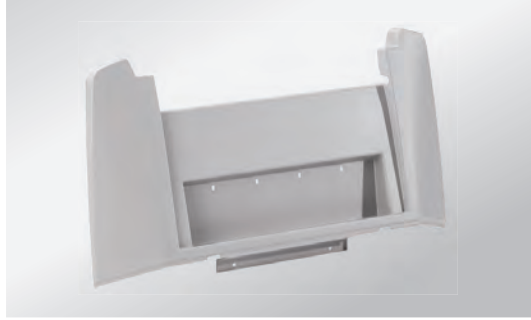

Seat cover

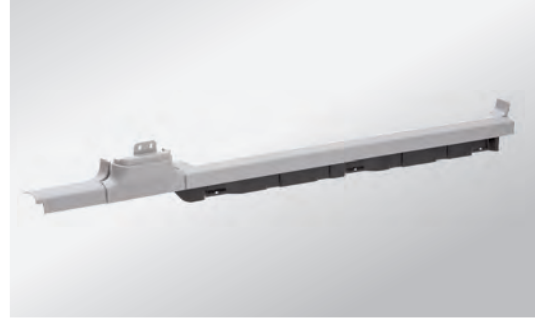

Socle wainscotting

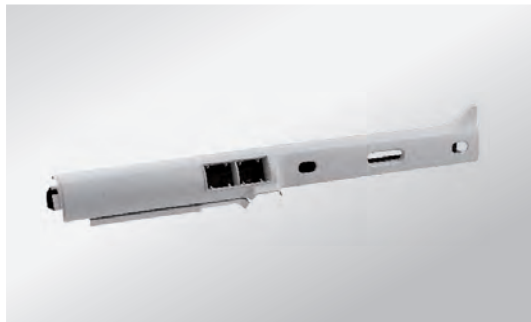

Roof frame panel



A-pillar trim (front and rear view)



Aperture through-loading



B-pillar trim (front and rear view)

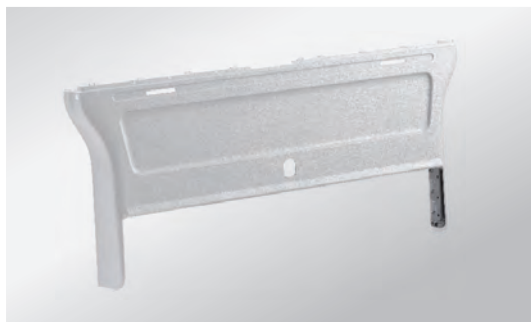

Tailgate panel



Sliding door panel



THE DUROTHERM GROUP

Since 1968, the DUROtherm Group has specialised in the development and production of high-quality vacuum moulded parts as well as plastic PUR and RRIM foam parts: Innovative moulded parts that leave nothing to be desired in terms of design variety, shape and size and are used in numerous industries. Due to the well-founded know-how of the employees and the state-of-the-art and large machinery, DUROtherm is one of the most important thermoforming companies in Europe today. In addition to five production plants in Germany, the DUROtherm Group has further branch plants in the Czech Republic and in Switzerland.

With around 400 employees, moulded parts are produced for a wide range of industries – the customer base includes numerous clients and industries. The company is also optimally positioned in terms of economic strength, machinery and production: Group sales have steadily increased over the years, and regular investments in additional equipment as well as the constant expansion of production areas are among the factors that ensure the success of the company.

The high quality standards of DUROtherm extend across all processes, from planning, through to production, to delivery in exact quantities, with the specified quality and on the agreed date. In order to constantly meet this high standard, all processes are organised within the framework of a quality management system according to IATF 16949:2016 and DIN EN ISO 9001:2015. In addition, DUROtherm attaches great importance to the conservation of resources and the environment and is therefore also certified according to EMAS, the European Union's quality seal for sustainable environmental management.



FULL RANGE OF SERVICES

Expert advice, careful planning

Careful planning of the individual project stands at the start of the company's holistic range of services. Depending on the task, the project team has project-specific planning groups available, which realise the customer's wishes by bringing in their in-depth know-how and many years of experience. The ultimate goal is to work out the optimum from the very beginning based on customer expectations and economic and technical feasibility, laying the foundation for a successful project.



High-tech CAD construction

Customers can also benefit from the know-how of DUROtherm engineers during development and design: From the concept and the first sketches, to the complex, coherent construction of several modules, to a "hands-on" model, DUROtherm offers all stages of product development. In close dialogue with the customer, design details are optimised with regard to their feasibility and material properties. This ensures the best possible functionality combined with innovative design is achieved.

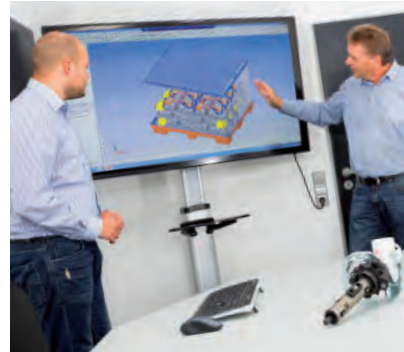

Prototyping: fast and flexible

On the basis of the CAD data taken over from the customer or developed by DUROtherm, high-quality sample or series tools are created within a very short time, which form the basis for optimum production. Final corrections and adjustments based on the customer's wishes can be implemented very promptly and cost-effectively. Due to decades of experience in the shaping of plastics, the choice of materials and the geometry of the deep-drawn parts are already taken into account in mould making, which guarantees a high degree of functionality for the later products.



Series production of consistently high quality

The most suitable process technology is used in series production depending on the task. As a result, DUROtherm is able to meet even the most difficult project requirements and to implement even unusual customer requirements. The state-of-the-art machinery combined with 3-shift production makes it possible to produce even large orders within the shortest possible time with consistently high production quality and to bridge bottlenecks optimally. For further processing of the thermoformed parts, innovative 5-axis-controlled CNC milling lines are available, and the latest CAD/CAM technology is used for programming. Individual parts, and even complete component groups, can be assembled and mounted in the large assembly department.

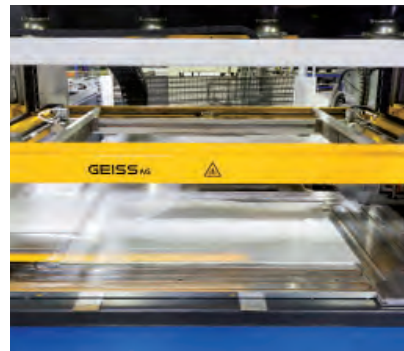

Well thought-out logistics processes

Thanks to a sophisticated logistics organisation, it is possible, on customer request, to keep even large quantities of goods available on short notice and on time. Order processing can be fully automated if required. To ensure uniform labelling and good traceability, all deliveries are made in accordance with VDA guidelines. The delivery notes can be transmitted online to the customer so that they are informed in detail about the quantity, content and time of arrival even before the arrival of the goods and can optimally manage further processing.





www.durotherm.de

YOUR POWERFUL PARTNER FOR THERMOFORMED PARTS

Specialist for vacuum formed parts since 1968. DUROtherm's primary concern is comprehensive customer satisfaction in all areas of collaboration. All our thoughts and actions and all processes are focused on this goal.

This strict focus on customer requirements is achieved both through sound consultation combined with technically perfect thermoformed parts, and also through a high degree of flexibility and reliability. Our friendly, helpful, well-trained staff is another factor that ensures consistent achievement of this goal.

The highest standards of quality, maximum flexibility and dependability, combined with cooperativeness and fairness are factors that contribute to our success, making DUROtherm a business partner that delivers high performance – now and in the future.

DUROtherm
Kunststoffverarbeitung GmbH
Industriestraße 52
72221 Haiterbach (Deutschland)
Telephone: +49 (0)7456 695-0
info@durotherm.de
www.durotherm.de

DUROtherm
Thermoforming Czechia s.r.o.
Alejni 630
41742 Krupka (Tschechien)
Telephone: +420 417 813911
info@durotherm.cz
www.durotherm.cz

CRISCO
Formtechnik AG
Augrabenstrasse 11
9466 Sennwald (Schweiz)
Telephone: +41 (0)81 7503600
info@crisco.ch
www.crisco.ch