

# Archetype

WHERE EVERYTHING BEGINS

 **EPOCA**  
*sprayers since 1968*

  
MADE IN ITALY



## 1968 - 2017

**We have been manufacturing plastic products for nearly 50 years and today we want to do more..**

Plastic..a word that commonly refers just to the material itself, has a thousand and more meanings to us.

Plastic things can be given shape and never change it: just like our plastic, floating in the empty space and never losing a bit of its strength and shape.

We want our products to look like this to you today: in their purest expression of form - not only for what they are used for, but for what they are: not just plastic.

We hope we have managed to do that!

### Why did we specialize?

To offer an Italian designed product, a manufacture Made in Italy, quality control and efficient logistics, assets, a family, a working group who faces daily challenges to meet your needs.

### Why are we innovative?

We want to offer a complete range of dynamic products, with the goal to constantly present novelties. Our aim is to allow you to renew your offer for your customers. **EPOCA** has been thoroughly selecting for years to reinvest company profits - and innovation and research are the most important sources for this choice.

### Why are we attractive and efficient?

For the care and attention that we put into every communication detail, from labels to instruction sheets, from packaging to advertising brochures that appear in specialized magazines in Italy and abroad. We are efficient in communication on the internet, media and social network too, and we take part, along with our distributors' network, to several international trade fairs and other events of geo-local marketing.

### Why are we reliable?

For our attention with respect to deliveries, and the strict checking adopted by our Quality Control System. In addition, we assure you to supply the products you've invested in with optimal performance standards – and in no time.

## CLEAR AND DETERMINATE GOALS

**THREE** is the common denominator of EPOCA's philosophy today,

**THREE** because three are the sisters leading the company

**THREE** because three are the core areas of business, like the three generations we care aiming at in the process of a generational relay,

**THREE** because three are the aspects that we treat with the utmost care: Customers, Products and Environment.

### Why are we solid?

To ensure you a feeling of solidity, and not just an image. Our increase in business volume and our growing presence into new markets, as well as consolidation of **EPOCA's** historical markets, are the result of a conscious selection and of a strong will of growth in Italy. The reverse of tendency is definitely a difficult decision, but it's one choice we continue to believe in.

### Why are we sustainable?

To offer hope to the environment and the opportunity for you to raise awareness among your customers in taking care, through daily activities, of a planet that we are ethically obliged to leave healthy to our children. Today 30% of our products are made of regenerated plastics, but in 2010 we were the first to build a market-leading line of items (Ecolove) with recycled plastic -and we have no intention to change direction. The choice of using recycled materials for our cardboard recyclable packaging, and to print our catalogues on FSC certified paper, has led us to the remarkable result of using more than 60% of recycled cartons, which are, of course, 100% recyclable.

### Why do we stand in solidarity?

To give hope to those who really need help support programs that promote health, human rights and education for adults and children (Doctors without Borders, the League of Golden Thread, AIRC, UNICEF and others). But the roots of solidarity within the company lie in the family members, who, all together, find the energy and the ability to solve problems, passing on to the employees a sense of belonging, source of tireless daily work. The sense of belonging which characterizes every member of Epoca is the engine of our success.



## ARCHETYPE

Epoca is proud to present a **brand new line of innovative pressure sprayers** under the name of **Archetype**.

Archetype sprayers are **Epoca's top sprayers** and they are widely used for industrial cleaning, chemical industry, industrial supplies and furthermore, thanks to their outstanding features, they are **ideal for the building and automotive field**.

**Archetype** includes sprayers in different capacities (1.5, 5 and 10 litres) available with different seals such as **VITON** (Fluorinated Hydrocarbon) and **EPDM** (Ethylene-Propylene-Diene). These types of seals grant excellent resistance to most chemicals.

### 1.5 LITRE PRESSURE SPRAYERS

The **1.5 litre sprayer** is fitted with our brand-new Kappa restyled head. The tank is available in black - for the VITON version - and in white - for the EPDM version; **gripping notches**, placed on top of the tank, improve the handling of the sprayer and a **sturdy base** enhance its stability. One of its main upside is that a translucent **view stripe** line with an integrated **embossed graduated scale** allows the user to monitor easily the level of the content of the tank. **A-Type 1.5 VITON** is also available with a **Polyamide (PA) head**.

translucent  
view stripe





## 5 AND 10 LITRES PRESSURE SPRAYERS

The **5 and 10 litres sprayers** are available in a **basic version - A-Type 5 & A-Type 10** - in a Premium version - **A-Type 5 PRE & A-Type 10 PRE** - fitted with wide stability base and in a **fully-fitted version - A-Type 5 PRO & A-Type 10 PRO** - with pressure gauge and check valve to connect air pump fitting.

Both versions have **sturdy tank** made of chemical-resistant plastic material and they are equipped with **padded waterproof straps, curved lance** and **vertical lance holder**.

The **fully-fitted** version is the first sprayer to have **four couplings right on the head** of the pump. Two of these couplings are designed to connect the lance tube and the safety valve, while the others host **the pressure gauge** and a coupling to connect **air pump fitting**. Furthermore, **two robust protection arches** will prevent any damage caused by accidental fall to the couplings and its devices.

We have decided to place all couplings not on the tank, but directly on the head of the sprayer, in order to give the tank a particular shape and to considerably enhance its performances and lifetime.

A-Type PRO is also equipped with a **large stability base** with a **reclosable compartment** to store the nozzles and spare O-rings.



## FOAMER SPRAYERS

Archetype line includes also a brand new **Foamer range** that consists of a 1.5 litre device - **AF-Type 1.5 Foamer** - and a 10 litres one - **AF-Type 10 PRO Foamer**. They are available both with **EPDM** and with **VITON** seals. These Foamer sprayers can be used efficiently both in professional cleaning field and in the car wash & car detailing.

AF-Type 1.5 Foamer, is fitted with a 110° foamer nozzle and it is particularly is meant to be used in small to medium size areas, while 10 litres pumps are equipped with a strong lance and they can be used on vast areas.

Finally **A-Type 6** is a black **watering can** with an **inclined angle spout** and it is designed to be used mainly on the service stations.



## A-TYPE 1.5 PRO



EPDM

VITON



brass insert



view stripe with graduated scale



### TECHNICAL SPECIFICATIONS

Total capacity ml	1860
Operating capacity ml	1500
Gasket	EPDM - VITON
Nozzle	adjustable
Safety valve	yes
Max pressure bar	3
Pumping rod	PP
Head colour EPDM	black-gray
Head colour VITON	black-blue
Bottle colour EPDM	white
Bottle colour VITON	black
Packing	bulk

### PLUS

- structural parts of the head in resistant polypropylene (PP)
- safety valve for automatic depressurization at + 3 bar;
- it can be used also manually for releasing the pressure, necessary prior to opening the container
- equipped with a protection cap that protects the non return valve from direct liquid contact prolonging its life time
- view stripe with graduated scale
- stability base
- gripping notches

CODE	GASKET	VERSION	EAN CODE	BOX				EURO PALLET	
				PCS/CTN	DIMENSIONS (cm)	WEIGHT (kg)	VOLUME (m <sup>3</sup> )	CTN/PLT	PCS/PLT
7830.R001	EPDM	with label - plastic nozzle	8003916066360	8	38,5 x 29,0 x 49,5	4,52	0,055	32	256
7840.R001	EPDM	anonymous - plastic nozzle	-	8	38,5 x 29,0 x 49,5	4,52	0,055	32	256
7882.R001	EPDM	anonymous - brass insert	-	8	38,5 x 29,0 x 49,5	4,54	0,055	32	256
7831.R001	VITON	with label - plastic nozzle	8003916066353	8	38,5 x 29,0 x 49,5	4,52	0,055	32	256
7841.R001	VITON	anonymous - plastic nozzle	-	8	38,5 x 29,0 x 49,5	4,52	0,055	32	256
7883.R001	VITON	anonymous - brass insert	-	8	38,5 x 29,0 x 49,5	4,54	0,055	32	256

## A-TYPE 1.5 PRO PA VITON



view stripe with graduated scale



### TECHNICAL SPECIFICATIONS

Total capacity ml	1860
Operating capacity ml	1500
Gasket	VITON
Nozzle	adjustable
Safety valve	yes
Max pressure bar	3
Pumping rod	PP
Head colour	black
Bottle colour	black
Packing	bulk

### PLUS

- structural parts of the head in resistant nylon (PA)
- safety valve for automatic depressurization at + 3 bar; it can be used also manually for releasing the pressure, necessary prior to opening the container.
- equipped with a protective cap that protects the non return valve from direct liquid contact prolonging its life time
- view stripe with graduated scale
- stability base
- gripping notches



brass insert

CODE	GASKET	VERSION	EAN CODE	BOX				EURO PALLET	
				PCS/CTN	DIMENSIONS (cm)	WEIGHT (kg)	VOLUME (m <sup>3</sup> )	CTN/PLT	PCS/PLT
7832.R001	VITON	with label - plastic nozzle	8003916066377	8	38,5 x 29,0 x 49,5	5,01	0,055	32	256
7842.R001	VITON	anonymous - plastic nozzle	-	8	38,5 x 29,0 x 49,5	5,01	0,055	32	256
7884.R001	VITON	anonymous - brass insert	-	8	38,5 x 29,0 x 49,5	5,04	0,055	32	256

# A-TYPE 5-10

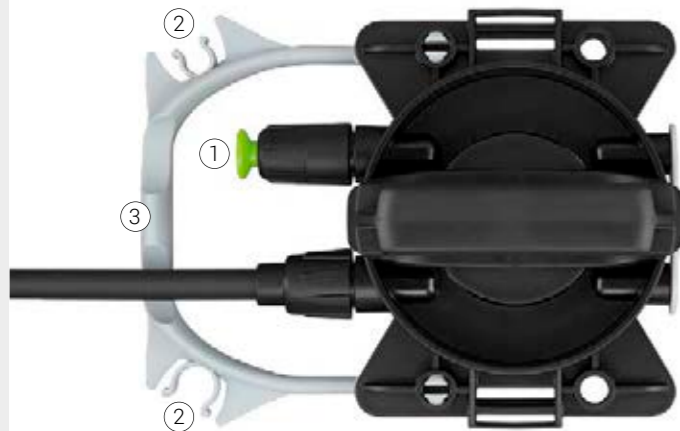

1. Safety valve
2. Vertical lance holder
3. Protective plastic bar



## A-TYPE 5



**TECHNICAL SPECIFICATIONS**

Total capacity ml	6500
Operating capacity ml	4875
Gasket	EPDM - VITON
Safety valve	yes
Max pressure bar	3
Head colour EPDM	black-gray
Head colour VITON	black-blue
Bottle colour	natural clear
Packing	single box

- PLUS**
- 1,4 m hose
  - protective plastic bar
  - vertical lance holder
  - sturdy tank made of chemical-resistant plastic material
  - padded waterproof straps
  - curved lance

CODE	GASKET	VERSION	EAN CODE	BOX				EURO PALLET	
				PCS/CTN	DIMENSIONS (cm)	WEIGHT (Kg)	VOLUME (m3)	CTN/PLT	PCS/PLT
7833.S001	EPDM	with label	8003916066452	1	19,5 x 19,5 x 42,5	2,25	0,016	120	120
7843.S001	EPDM	anonymous	-	1	19,5 x 19,5 x 42,5	2,25	0,016	120	120
7834.S001	VITON	with label	8003916066452	1	19,5 x 19,5 x 42,5	2,25	0,016	120	120
7844.S001	VITON	anonymous	-	1	19,5 x 19,5 x 42,5	2,25	0,016	120	120

## A-TYPE 10



**TECHNICAL SPECIFICATIONS**

Total capacity ml	11230
Operating capacity ml	8422
Gasket	EPDM - VITON
Safety valve	yes
Max pressure bar	3
Head colour EPDM	black-gray
Head colour VITON	black-blue
Bottle colour	natural clear
Packing	single box

- PLUS**
- 1,4 m hose
  - protective plastic bar
  - vertical lance holder
  - sturdy tank made of chemical-resistant plastic material
  - padded waterproof straps
  - curved lance

CODE	GASKET	VERSION	EAN CODE	BOX				EURO PALLET	
				PCS/CTN	DIMENSIONS (cm)	WEIGHT (Kg)	VOLUME (m3)	CTN/PLT	PCS/PLT
7837.S001	EPDM	with label	8003916066476	1	19,5 x 19,5 x 60,0	4,52	0,055	84	84
7847.S001	EPDM	anonymous	-	1	19,5 x 19,5 x 60,0	4,52	0,055	84	84
7838.S001	VITON	with label	8003916066469	1	19,5 x 19,5 x 60,0	4,54	0,055	84	84
7848.S001	VITON	anonymous	-	1	19,5 x 19,5 x 60,0	4,52	0,055	84	84

# A-TYPE 5-10 PRE

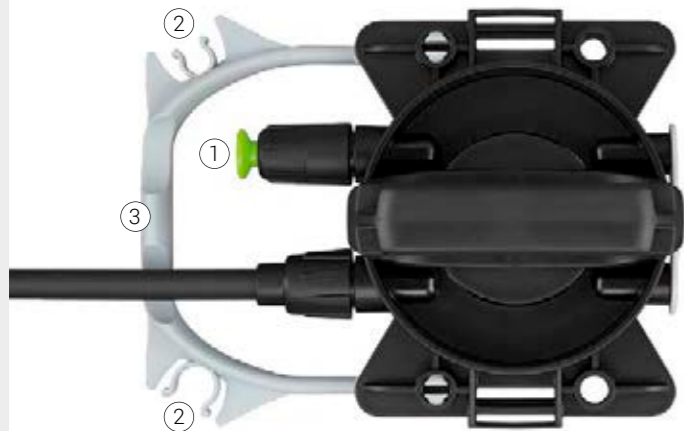

1. Safety valve
2. Vertical lance holder
3. Protective plastic bar
4. Extra wide stability base
5. Spare parts reclosable storage

## A-TYPE 5 PRE



**TECHNICAL SPECIFICATIONS**

Total capacity ml	6500
Operating capacity ml	4875
Gasket	EPDM - VITON
Safety valve	yes
Max pressure bar	3
Head colour EPDM	black-gray
Head colour VITON	black-blue
Bottle colour	natural clear
Packing	single box

- PLUS**
- 2 m hose
  - protective plastic bar
  - vertical lance holder
  - sturdy tank made of chemical-resistant plastic material
  - padded waterproof straps
  - extra wide stability base with nozzles & spare parts reclosable storage
  - curved lance with adjustable and fan effect nozzle - 110° angle

CODE	GASKET	VERSION	EAN CODE	BOX				EURO PALLET	
				PCS/CTN	DIMENSIONS (cm)	WEIGHT (Kg)	VOLUME (m3)	CTN/PLT	PCS/PLT
7865.S001	EPDM	with label	8003916066520	1	29,0 x 25,0 x 40,0	2,74	0,029	60	60
7875.S001	EPDM	anonymous	-	1	29,0 x 25,0 x 40,0	2,74	0,029	60	60
7866.S001	VITON	with label	8003916066513	1	29,0 x 25,0 x 40,0	2,74	0,029	60	60
7876.S001	VITON	anonymous	-	1	29,0 x 25,0 x 40,0	2,74	0,029	60	60

## A-TYPE 10 PRE



**TECHNICAL SPECIFICATIONS**

Total capacity ml	11230
Operating capacity ml	8422
Gasket	EPDM - VITON
Safety valve	yes
Max pressure bar	3
Head colour EPDM	black-gray
Head colour VITON	black-blue
Bottle colour	natural clear
Packing	single box

- PLUS**
- 2 m hose
  - protective plastic bar
  - vertical lance holder
  - sturdy tank made of chemical-resistant plastic material
  - padded waterproof straps
  - extra wide stability base with nozzles & spare parts reclosable storage
  - curved lance with adjustable and fan effect nozzle - 110° angle

CODE	GASKET	VERSION	EAN CODE	BOX				EURO PALLET	
				PCS/CTN	DIMENSIONS (cm)	WEIGHT (Kg)	VOLUME (m3)	CTN/PLT	PCS/PLT
7867.S001	EPDM	with label	8003916066544	1	29,0 x 25,0 x 58,5	3,25	0,042	42	42
7877.S001	EPDM	anonymous	-	1	29,0 x 25,0 x 58,5	3,25	0,042	42	42
7868.S001	VITON	with label	8003916066537	1	29,0 x 25,0 x 58,5	3,25	0,042	42	42
7878.S001	VITON	anonymous	-	1	29,0 x 25,0 x 58,5	3,25	0,042	42	42

# A-TYPE 5-10 PRO

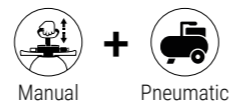

1. Safety valve
2. Vertical lance holder
3. Protective plastic bar
4. Extra wide stability base
5. Spare parts reclosable storage
6. Unidirectional valve to connect air pump fittings
7. Pressure gauge

## A-TYPE 5 PRO



**TECHNICAL SPECIFICATIONS**

Total capacity ml	6500
Operating capacity ml	4875
Gasket	EPDM - VITON
Safety valve	yes
Max pressure bar	3
Head colour EPDM	black-gray
Head colour VITON	black-blue
Bottle colour	natural clear
Packing	single box

- PLUS**
- 2 m hose
  - unidirectional valve to connect air pump fittings
  - pressure gauge
  - protective plastic bar
  - vertical lance holder
  - sturdy tank made of chemical-resistant plastic material
  - padded waterproof straps
  - extra wide stability base with nozzles & spare parts reclosable storage
  - curved lance with adjustable and fan effect nozzle - 110° angle

CODE	GASKET	VERSION	EAN CODE	BOX				EURO PALLET	
				PCS/CTN	DIMENSIONS (cm)	WEIGHT (Kg)	VOLUME (m3)	CTN/PLT	PCS/PLT
7835.S001	EPDM	with label	8003916066414	1	29,0 x 25,0 x 40,0	2,88	0,029	60	60
7845.S001	EPDM	anonymous	-	1	29,0 x 25,0 x 40,0	2,88	0,029	60	60
7836.S001	VITON	with label	8003916066407	1	29,0 x 25,0 x 40,0	2,88	0,029	60	60
7846.S001	VITON	anonymous	-	1	29,0 x 25,0 x 40,0	2,88	0,029	60	60

## A-TYPE 10 PRO



**TECHNICAL SPECIFICATIONS**

Total capacity ml	11230
Operating capacity ml	8422
Gasket	EPDM - VITON
Safety valve	yes
Max pressure bar	3
Head colour EPDM	black-gray
Head colour VITON	black-blue
Bottle colour	natural clear
Packing	single box

- PLUS**
- 2 m hose
  - unidirectional valve to connect air pump fittings
  - pressure gauge
  - protective plastic bar
  - vertical lance holder
  - sturdy tank made of chemical-resistant plastic material
  - padded waterproof straps
  - extra wide stability base with nozzles & spare parts reclosable storage
  - curved lance with adjustable and fan effect nozzle - 110° angle

CODE	GASKET	VERSION	EAN CODE	BOX				EURO PALLET	
				PCS/CTN	DIMENSIONS (cm)	WEIGHT (Kg)	VOLUME (m3)	CTN/PLT	PCS/PLT
7839.S001	EPDM	with label	8003916066438	1	29,0 x 25,0 x 58,5	3,39	0,042	42	42
7849.S001	EPDM	anonymous	-	1	29,0 x 25,0 x 58,5	3,39	0,042	42	42
7850.S001	VITON	with label	8003916066421	1	29,0 x 25,0 x 58,5	3,39	0,042	42	42
7860.S001	VITON	anonymous	-	1	29,0 x 25,0 x 58,5	3,39	0,042	42	42



## A-TYPE 1.5 PRO FOAMER



### TECHNICAL SPECIFICATIONS

Total capacity ml	1860
Operating capacity ml	1000
Gasket	EPDM - VITON
Nozzle	fan effect
Safety valve	yes
Max pressure bar	3
Pumping rod	PP
Head colour EPDM	black-gray
Head colour VITON	black-blue
Bottle colour EPDM	white
Bottle colour VITON	black
Packing	bulk

### PLUS

- structural parts of the head in resistant polypropylene (PP)
- safety valve for automatic depressurization at + 3 bar; it can be used also manually for releasing the pressure, necessary prior to opening the container.
- equipped with foam nozzle lance
- sturdy tank made of chemical-resistant plastic material
- fan effect nozzle - 110° angle
- view stripe with graduated scale
- stability base
- gripping notches

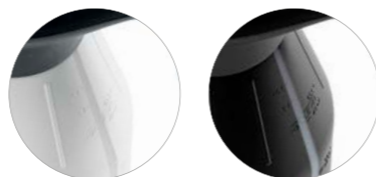

CODE	GASKET	VERSION	EAN CODE	BOX				EURO PALLET	
				PCS/CTN	DIMENSIONS (cm)	WEIGHT (Kg)	VOLUME (m3)	CTN/PLT	PCS/PLT
7851.R001	EPDM	with label	8003916066391	8	38,5 x 29,0 x 49,5	4,44	0,055	32	256
7861.R001	EPDM	anonymous	-	8	38,5 x 29,0 x 49,5	4,44	0,055	32	256
7852.R001	VITON	with label	8003916066384	8	38,5 x 29,0 x 49,5	4,44	0,055	32	256
7862.R001	VITON	anonymous	-	8	38,5 x 29,0 x 49,5	4,44	0,055	32	256

## A-TYPE 10 PRO FOAMER



### TECHNICAL SPECIFICATIONS

Total capacity ml	11230
Operating capacity ml	6000
Gasket	EPDM - VITON
Safety valve	yes
Max pressure bar	3
Head colour EPDM	black-gray
Head colour VITON	black-blue
Bottle colour	natural clear
Packing	single box



### PLUS

- 2 m hose
- unidirectional valve to connect air pump fittings
- pressure gauge
- protective plastic bar
- vertical lance holder
- sturdy tank made of chemical-resistant plastic material
- padded waterproof straps
- extra wide stability base with nozzles & spare parts reclosable storage
- equipped with curved foam nozzle lance
- fan effect nozzle - 110° angle

CODE	GASKET	VERSION	EAN CODE	BOX				EURO PALLET	
				PCS/CTN	DIMENSIONS (cm)	WEIGHT (Kg)	VOLUME (m3)	CTN/PLT	PCS/PLT
7853.S001	EPDM	with label	8003916066490	1	29,0 x 25,0 x 58,5	3,41	0,042	42	42
7863.S001	EPDM	anonymous	-	1	29,0 x 25,0 x 58,5	3,41	0,042	42	42
7854.S001	VITON	with label	8003916066483	1	29,0 x 25,0 x 58,5	3,41	0,042	42	42
7864.S001	VITON	anonymous	-	1	29,0 x 25,0 x 58,5	3,41	0,042	42	42

## A-TYPE 6



### TECHNICAL SPECIFICATIONS

Total capacity ml	6050
Packing	bulk

### PLUS

- with inclined angle spout

CODE	COLORE	EAN CODE	BOX				EURO PALLET	
			PZ/SAC. PL.	DIMENSIONS (cm)	WEIGHT (Kg)	VOLUME (m3)	SAC. PL./PLT	PCS/PLT
7855.S001	black	8003916070985	12	84,0 x 56,0 x 31,0	3,36	0,146	14	168

### EPDM

Gaskets in Ethylene-Propylene-Diene. Ideal with glycol-based hydraulic fluids and organic and inorganic acids, detergents, solutions of sodium and potassium, oxygenated solvents (ketones and esters), and atmospheric agents.

### VITON

Gaskets in Fluorinated Hydrocarbon. Ideal with oils and mineral fats silicone based, animal and vegetable oils, aliphatic hydrocarbons, aromatic hydrocarbons, very good resistance to weather, ozone, oxygen and sunlight.

Epoca recommends testing a sample of the product in question (including its seals) with your chemical compositions.



for manufacturing defects







EPOCA SPA  
LOCALITÀ SAN LAZZARO  
VIA SANT'ANDREA 24  
36061 BASSANO DEL GRAPPA (VI) - ITALY

Tel. +39 0424 88 49 11 - Fax +39 0424 56 72 46  
info@epocaspa.com - www.epocaspa.com



UK