

*The effective technology and complex services*

# Farmet®



## PRODUCT RANGE

FARMET AGRICULTURAL MACHINERY

### 2020



**extra STEEL line®**  
ultra high strength steel technology







Farmet a. s. is the Czech engineering company with the tradition since 1992. Its production program is divided into two divisions. **Agricultural Machinery Division** specializes in the development and production of agricultural machines for the soil treatment and sowing. **Oil & Feed Tech Division** is the leading global manufacturer and supplier of technologies of processing oilseeds, vegetable oil refining and filtration, and feed extrusion.



**EU HOMOLOGATION**

<b>FARMET a.s.</b> <b>S2a</b> <b>e8*167/2013*00060*00</b> <b>FAR12580JK0000783</b> 10000 kg A-0: 3000 kg A-1: 10000 kg A-2: ----- kg A-3: ----- kg		 Jiřínková 276 552 03 Česká Skalice MADE IN CZECH REPUBLIC	
<b>SOFTER SF12,5PS</b>			
ROK/ YEAR	<b>2019</b>	CELK. HMOTNOST/ TOTAL WEIGHT	<b>13000 kg</b>
kg	T-1	T-2	T-3
B-1	---	---	---
B-2	---	---	---
B-3	---	---	---
B-4	---	---	---
		 <a href="http://www.farmet.cz">www.farmet.cz</a>	
			





# eXtra STEEL line®

ultra high strength steel technology

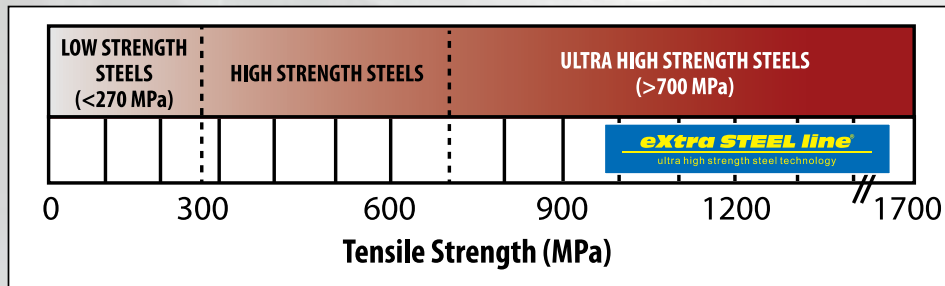

## Frame from high-strength steel

- 3 times higher strength and high flexibility of construction
- Significantly lower weight of machine
- Used on frame, working units and extremely burdened parts
- For extended service life of machine
- Fuel economy

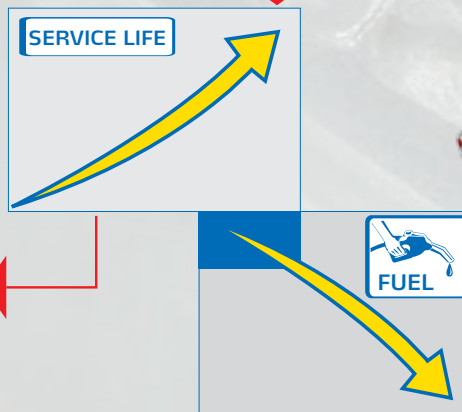

# CONTENT

## SHALLOW SOIL PROCESSING

 | 4–15 cm

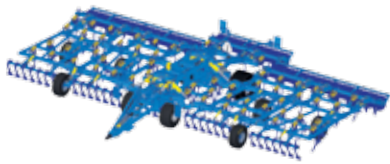

**FANTOM** | 6

 | 3,5–12 cm

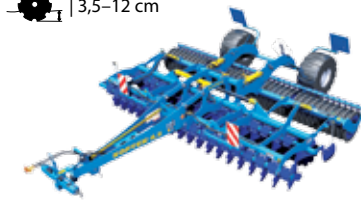

**SOFTER  
SOFTER & SYNCULT** | 10

 | 5–18 cm

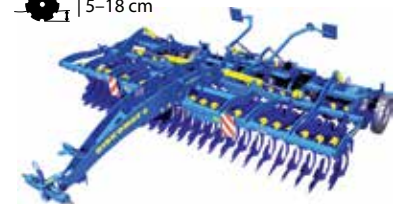

**DISKOMAT** | 16

## DEEP SOIL PROCESSING

 | 10–35 cm



**TERRIX  
TERRIX DUAL** | 20

 | 3,5–12 cm



**TRITON** | 22

 | 6–35 cm

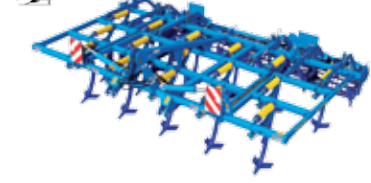

**TRIOLENT  
DUOLENT** | 24

 | 6–35 cm



**FERTIS** | 30

 | 20–35 cm



**STRIP-TILL** | 31

 | 25–50 cm



**DIGGER** | 34

 | 25–50 cm



**DIGGER FERT+  
DIGGER FERT+ COMPACT** | 37

 | 30–60 cm

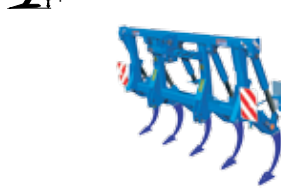

**KRTEK** | 38

## PRESOWING PREPARATION

 | 0–10 cm

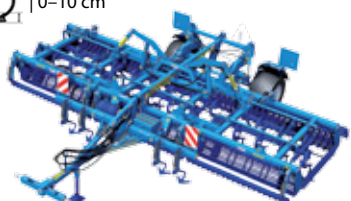

**KONPAKTOMAT** | 40



**DV** | 49

 | 0–10 cm

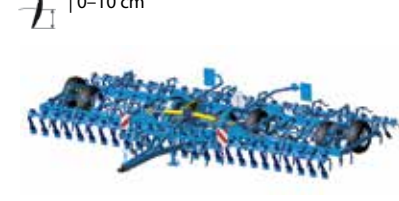

**VERSO** | 50



**SOWING**



**FALCON PRO** | 54



**FALCON STRIP** | 60



**FALCON TANDEM** | 62



**FALCON SW** | 64



**FALCON COMPACT** | 67



**IMPACT** | 68



**MONSUN** | 70

**CULTIVATION, ROLLING, MANURE MANAGEMENT**

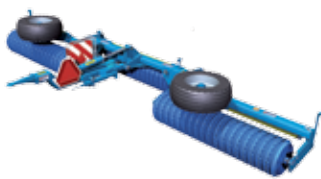

**CAMBRIDGE** | 72



**KULTIS** | 73



**ELEFANT** | 74

**OIL & FEED TECH**



**OIL & FEED TECH** | 75



# FANTOM

share cultivators

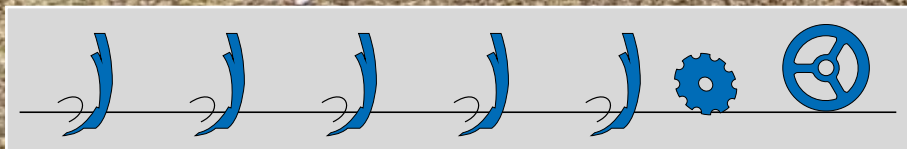

Cultivator Fantom is especially suitable for **full-area post harvest stubble-breaking with intensive mixing effect**. The soil is processed up to the depth of 15 cm. It allows stubble-breaking, loosening and pre-sowing preparations.

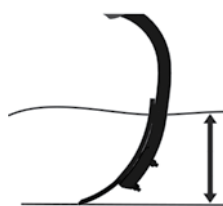

40–150 mm (1.6–6 in)

**8–12 km/h**  
**5–7 mph**

**eXtra STEEL line**  
ultra high strength steel technology



N

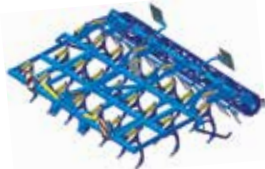

NS



CLASSIC

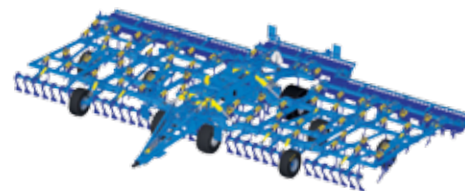

PRO



- Due to its design, the Fantom NS cultivator is **very versatile** and can be used for stubble breaking, pre-sowing soil processing or incorporation of manure. Machine's low weight decreases by loading of the rear parts of tractors during transport. Thanks to its simple and massive design, the Fantom cultivator offers an **optimal compromise between the acquisition price and utility value.**

### High performance and quality of work

- Low traction resistance** and excellent mixing of the soil due to the optimized design of ploughshares.
- Precise deep guiding** with optimum soil compaction.
- Excellent penetration of the tines into the soil.
- Maintenance-free working units** fitted with plates of cemented carbides for minimal wear.
- The design of the ploughshares ensures **high passability** for plant residues.

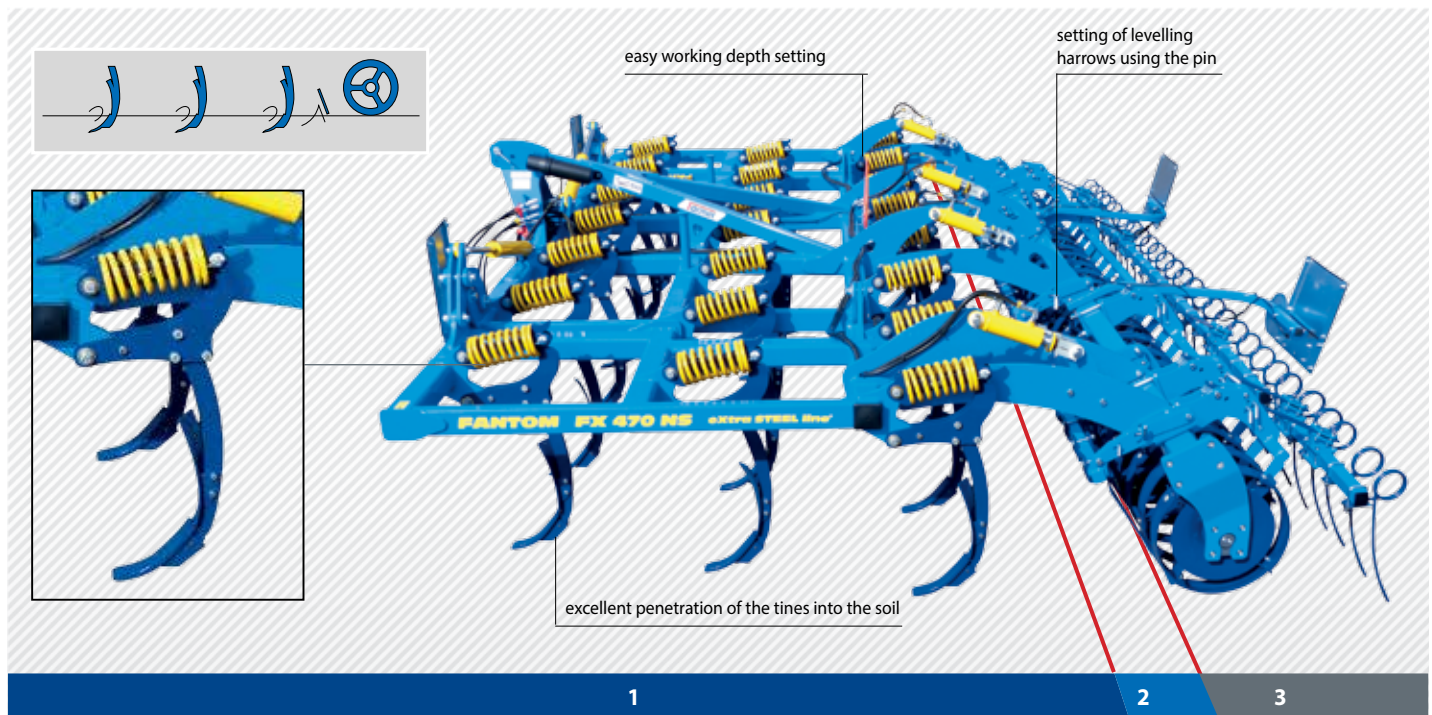

1. The soil is cultivated by the tines in three rows.
2. The rod levelling bar ("RR" and "TR" roller) levels out the surface.
3. The soil is compacted by the rear roller (Optional rollers, page 39)

Technical parameters	Units	Fantom 300 N	Fantom 350 N	Fantom 470 NS
Working width	mm / ft	3000 / 9.8	3500 / 11.5	4700 / 15.4
Transport width	mm / ft	3000 / 9.8	3500 / 11.5	3000 / 9.8
Transport height	mm / ft	1330 / 4.4	1380 / 4.5	1930 / 6.3
Total machine length	mm / ft	3330 / 11	3330 / 11	3450 / 11.3
Working depth	mm / in	40–150 / 1.6–6	40–150 / 1.6–6	40–150 / 1.6–6
Number of ploughshares	pcs	14	16	22
Working performance	ha/h (ac/h)	2.4–3.6 (6–8.8)	2.8–4.2 (7–10.4)	3.7–5.5 (9.1–13.6)
Towing vehicle	kW / HP	110–165 / 150–225	120–180 / 160–240	150–225 / 200–300
Machine weight	kg / lb.	1100 / 2425	1350 / 2976	2000 / 4409

More info at [www.farmet.eu](http://www.farmet.eu)





# FANTOM CLASSIC

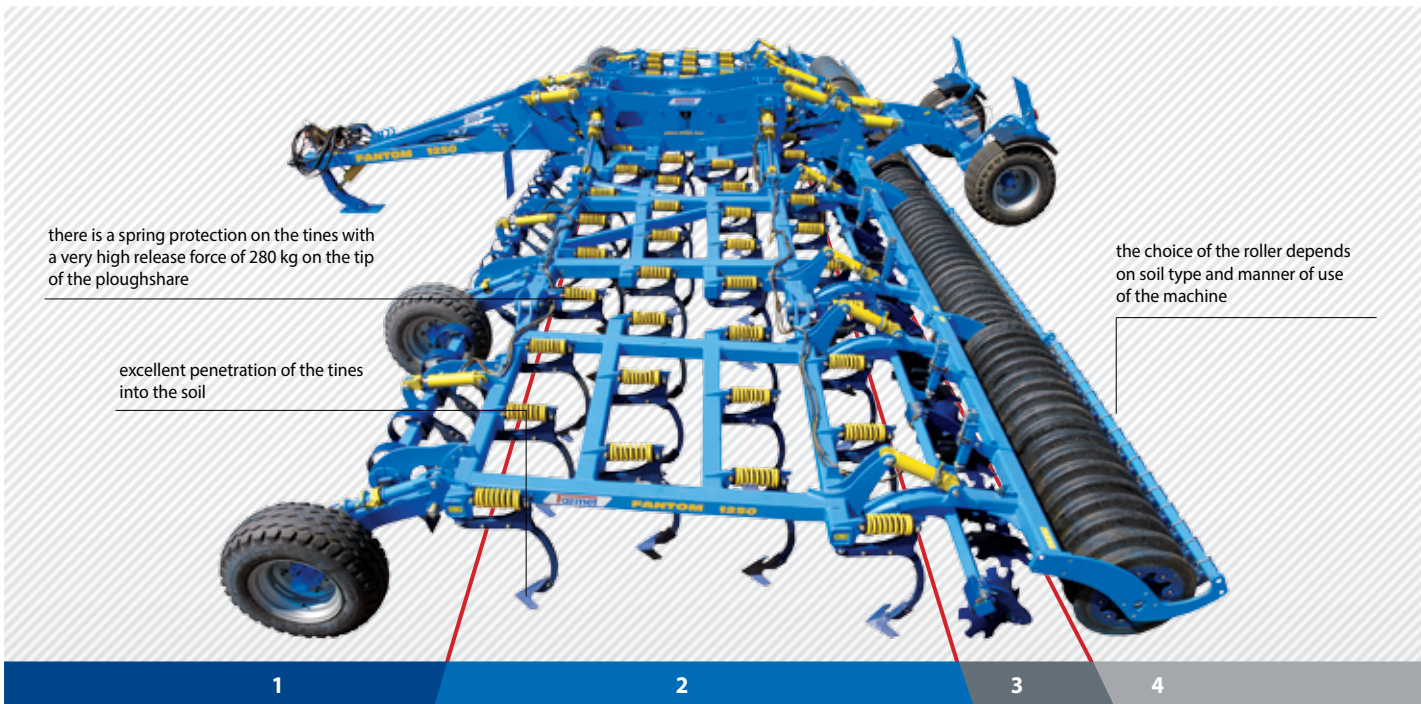

there is a spring protection on the tines with a very high release force of 280 kg on the tip of the ploughshare

excellent penetration of the tines into the soil

the choice of the roller depends on soil type and manner of use of the machine

1. Hydraulically controlled front flexi-board leveller for smoothing of the soil surface and crumbling of clods before the whole processing.
2. Optional working bodies in 4 rows **A / B / C**
3. The rear coordination disks located behind the working bodies in front of the row of rollers with the aim to level the soil surface in front of the rollers are easily height-adjustable.
4. Optional rear rollers for various conditions. (page 39)



Technical parameters	Units	Fantom 1250 CLASSIC
Working width	mm / ft	12500 / 41.1
Transport width	mm / ft	3000 / 9.8
Working depth	mm / in	40–150 / 1.6–6
Number of ploughshares	pcs	65
Working performance	ha/h (ac/h)	10.0–15.0 (24.7–37)
Towing vehicle	kW / HP	330–440 / 450–675
Machine weight	kg / lb.	11220 / 24736

More info at [www.farmet.eu](http://www.farmet.eu)

**Quick-change share system**

A - standard	B - long life	C - stubble cultivation

reinforced carbide shares





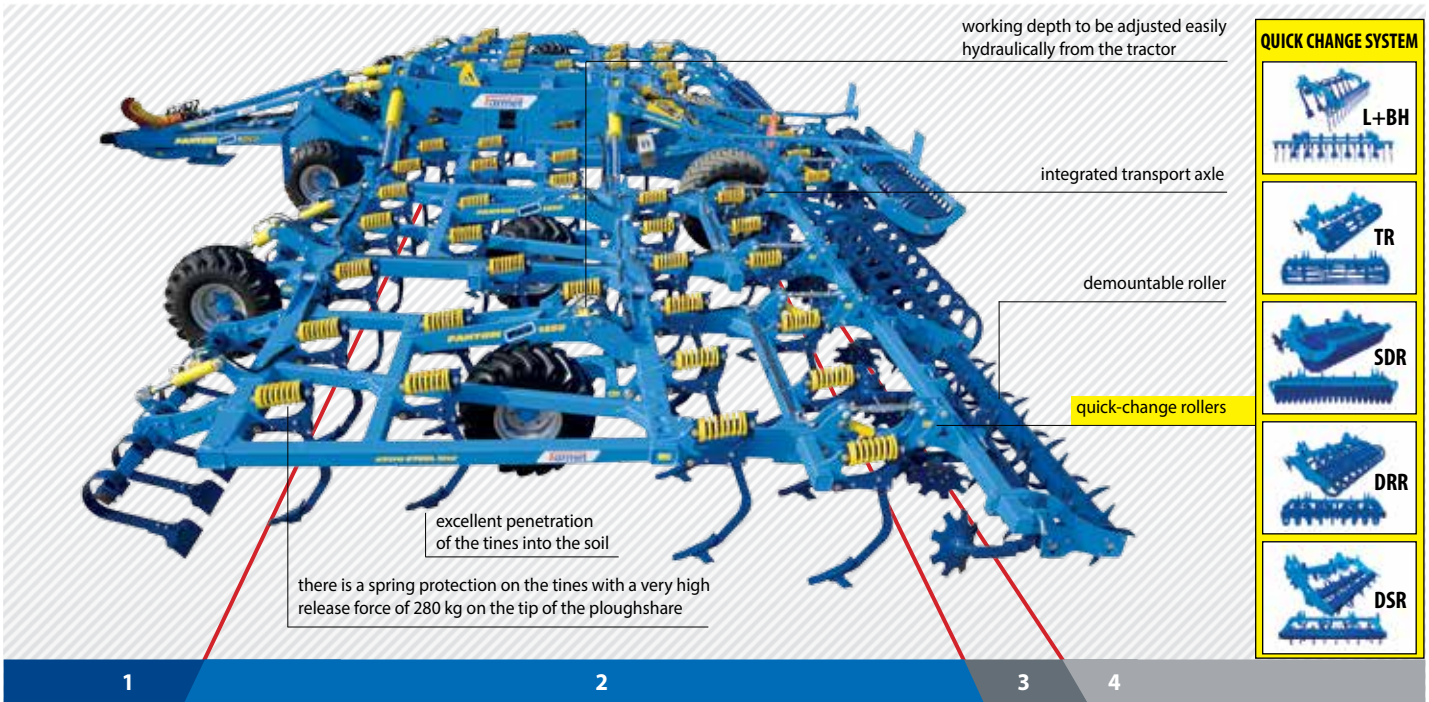

1. Hydraulically controlled front flexi-board leveller for smoothing of the soil surface and crumbling of clods before the whole processing.
2. Optional working bodies in 5 rows **A / B / C**
3. The rear coordination disks located behind the working bodies in front of the row of rollers with the aim to level the soil surface in front of the rollers are easily height-adjustable.
4. Optional rear rollers for various conditions. (page 39). **Option of working without the optional rollers and guiding disks.**



The semi-mounted 5-row modular Fantom PRO cultivator with a low tractive resistance and a variable soil cultivation depth is suitable for spring, summer and autumn works and its modularity provides for early spring works as the machine also manages to work with moister soil.

Technical parameters	Units	Fantom 650 PRO	Fantom 800 PRO	Fantom 850 PRO	Fantom 1050 PRO	Fantom 1250 PRO
Working width	mm / ft	6500 / 21.3	8000 / 26.3	8500 / 27.9	10500 / 34.5	12500 / 41.1
Transport width	mm / ft	3000 / 9.8 (3060 / 10)*	3000 / 9.8 (3060 / 10)*	3000 / 9.8 (3060 / 10)*	3000 / 9.8 (3060 / 10)*	3000 / 9.8 (3060 / 10)*
Working depth	mm / in	40–150 (180)* / 1.6–6 (7)*	40–150 (180)* / 1.6–6 (7)*	40–150 (180)* / 1.6–6 (7)*	40–150 (180)* / 1.6–6 (7)*	40–150 (180)* / 1.6–6 (7)*
Number of ploughshares	pcs	35	43	45	57	67
Working performance	ha/h (ac/h)	4.8–7.2 (11.8–17.8)	6.4–9.6 (15.8–23.8)	6.8–10.2 (16.8–25.2)	8.0–12.0 (20–30)	10.0–15.0 (24.7–37)
Towing vehicle	kW / HP	200–300 / 270–405	230–350/310–475	245–370 / 330–495	295–400 / 400–550	330–440 / 450–675
Machine weight	kg / lb.	5022 / 11074	8950 / 19736	9150 / 20175	11160 / 24608	14480 / 31929

\* by using special thin chisels. More info at [www.farmet.eu](http://www.farmet.eu)





# SOFTER

disk plough-harrows

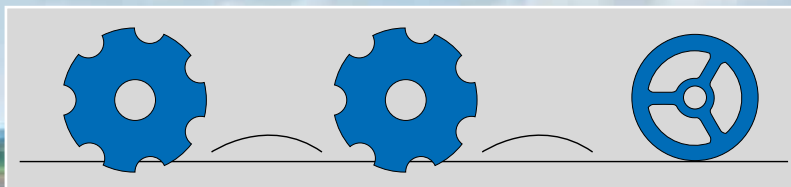





Disk plough-harrow Softer is especially suitable for **shallow stubble-breaking with perfect undercut and intensively mixed plant residues**. It incorporates organic fertilizer, catch crops or difficult vegetation. **Intensively prepares the sowing bed** after stubble-breaking or ploughing with optimum recompaction of the soil.

Ø 510 mm (20 in)

Ø 560 mm (22 in)

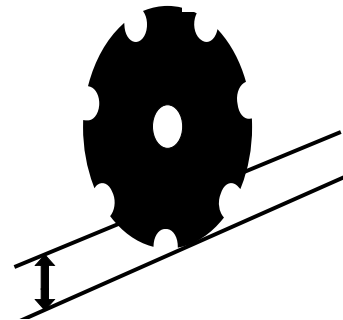

35–120 mm (1,5–4,5 in)

**10–15 km/h**  
**6–9 mph**



N



NS



PS



PS

**eXtra STEEL line®**  
ultra high strength steel technology



# SOFTER N/NS

- The main advantage of disk plough-harrow Softer is a **universal usage from the first stubble-breaking to subsequent pre-sowing preparation of the soil** after the stubble-breaking or ploughing.
- **Simple design with increased resistance.** When used with a tractor of sufficient traction power, Softer enables preparation of soil with **speeds up to 15 km/h**. It guarantees easy incorporation of plant residues into the top-soil after harvest. Softer is characterized with **simple design with increased resistance, compactness and versatility** with a minimum of adjusting and lubricating points. High pressure to each disk together with dentate circumference ensures optimum penetration even to heavy and over-dried soil.
- Very short structure of the machine results in **precise deep guiding, excellent stability at work and effective quick turning at headlands.**

## High performance and quality of work

- High working speed **up to 15 km/h**.
- Gear disks for trouble-free penetration into the soil and intensive mixing.
- Working angle of disks and pressure to each disk ensure **uncompromising penetration even to heavy and over-dried soils** and perfect undercut of the processed profile.
- High quality rubber mounting for **optimal working angles of the disks**.
- **Precise deep guiding** with optimum soil compaction.
- Disks with the diameter of 510 / 560 mm are located in two rows. For the case of contact with some obstacle, each disk is **separately effectively protected** by means of rubber mounting.

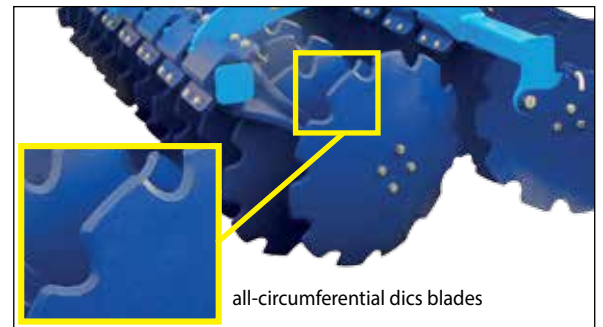

## Robust design

- **High-strength refined materials** in connection with **eXtra STEEL line** technology guarantee long service life of our machines even in the most difficult conditions.
- **High-strength refined materials** used for crucial nodes to ensure long service life. Strongly dimensioned frame of high-strength steel.
- **Maintenance-free placement of disks** ensuring operation of the machine with no need of additional lubrication.
- Resistant and **maintenance-free rubber mounting** for adaptation to terrain with protection against overload.





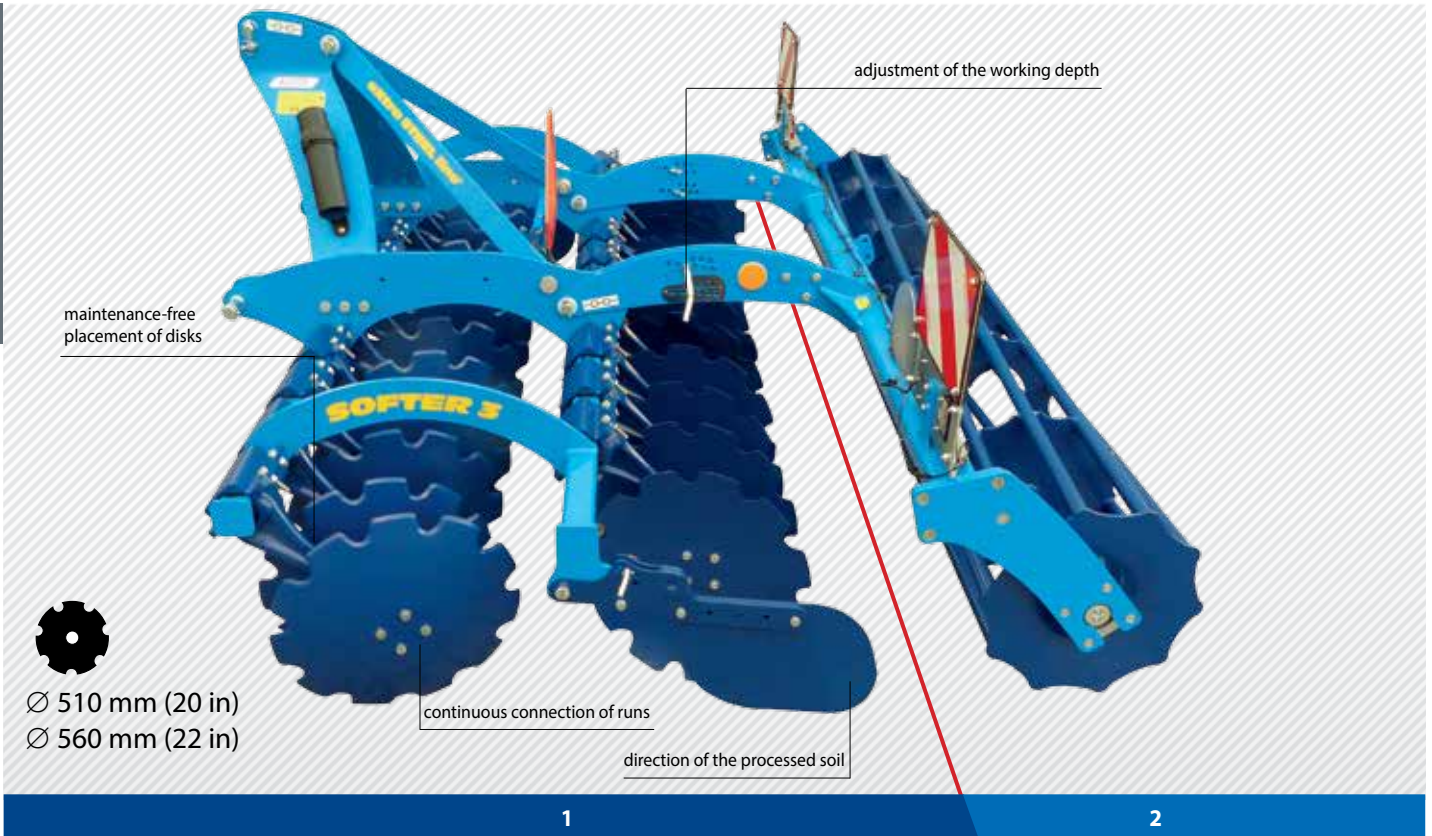

1. Disks with the diameter of 510 mm / 560 mm located in two rows will undercut the soil. Working depth is 3,5–12 cm.
2. Clods are crumbled by the rear roller. (Optional rollers, page 39)



Technical parameters	Units	Softer 2,5 N	Softer 3 N	Softer 3,5 N	Softer 4,5 NS* Softer 4,5 NS Syncult	Softer 5 NS* Softer 5 NS Syncult	Softer 6 NS* Softer 6 NS Syncult
Working width	mm / ft	2400 / 7.9	2900 / 9.5	3500 / 11.5	4500 / 14.8	5000 / 16.4	6000 / 19.7
Transport width	mm / ft	2500 / 8.2	3000 / 9.8	3500 / 11.5	3000 / 9.8	3000 / 9.8	3000 / 9.8
Transport height	mm / ft	1370 / 4.5	1370 / 4.5	1370 / 4.5	2500 / 8.2	3000 / 9.8	3300 / 10.8
Total machine length	mm / ft	2500 / 8.2	2500 / 8.2	2500 / 8.2	2700 / 8.9	2700 / 8.9	2700 / 8.9
Working depth	mm / in	35–120 / 1.5–4.5	35–120 / 1.5–4.5	35–120 / 1.5–4.5	35–120 / 1.5–4.5	35–120 / 1.5–4.5	35–120 / 1.5–4.5
Number of ploughshares	pcs	20	24	28	38	42	50
Working performance	ha/h (ac/h)	2.5–3.8 (6–9)	3–4.5 (7–11)	3.5–5.3 (9–13)	4.5–7 (11–17)	5–7.5 (12–18)	6–9 (15–22)
Towing vehicle	kW / HP	65–100 / 90–140	80–120 / 110–165	90–140 / 120–190	120–180 / 160–240	130–190 / 180–260	150–225 / 200–300
Machine weight	kg / lb.	1400 / 3100	1540 / 3400	1950 / 4300	2950 / 6505	3150 / 6930	3650 / 8050



More info at [www.farmet.eu](http://www.farmet.eu)





# SOFTER PS

- The main advantage of disk plough-harrow Softer is an **universal usage** from the first stubble-breaking to subsequent **pre-sowing preparation of the soil** after the stubble-breaking or ploughing.
- Softer is characterized with **simple design with increased resistance, compactness and versatility** with a minimum of adjusting and lubricating points. When used with a tractor of sufficient traction power, Softer enables preparation of soil **with speeds up to 15 km/h**. It guarantees easy incorporation of plant residues into the top-soil after harvest. High pressure to each disk together with dentate circumference ensures optimum penetration even to heavy and over-dried soil.
- **Excellent stability and precise deep guiding**. Very short structure of the machine results in precise deep guiding, excellent stability at work and effective quick turning at headlands.

## High performance and quality of work

- High working speed **up to 15 km/h**.
- Working angle of the disks and pressure to each disk ensure **uncompromising penetration even to heavy and over-dried soils** and perfect undercut of the processed profile.
- High quality rubber mounting for **optimal working angles** of the disk.
- **Precise deep guiding** with optimum soil compaction.
- Disks with the diameter of 510 / 560 mm are located in two rows. For the case of contact with an obstacle, each disk is **separately effectively protected** by means of rubber mounting.



## Robust design

- **High-strength refined materials** in connection with **eXtra STEEL line** technology guarantee long service life of our machines even in the most difficult conditions.
- **High-strength refined materials** used for crucial nodes to ensure long service life. Strongly dimensioned frame from high-strength steels.
- **Maintenance-free placement** of the disks ensuring operation of the machine with no need of additional lubrication.
- Resistant and **maintenance-free rubber mounting** for adaptation to terrain with protection against overload.





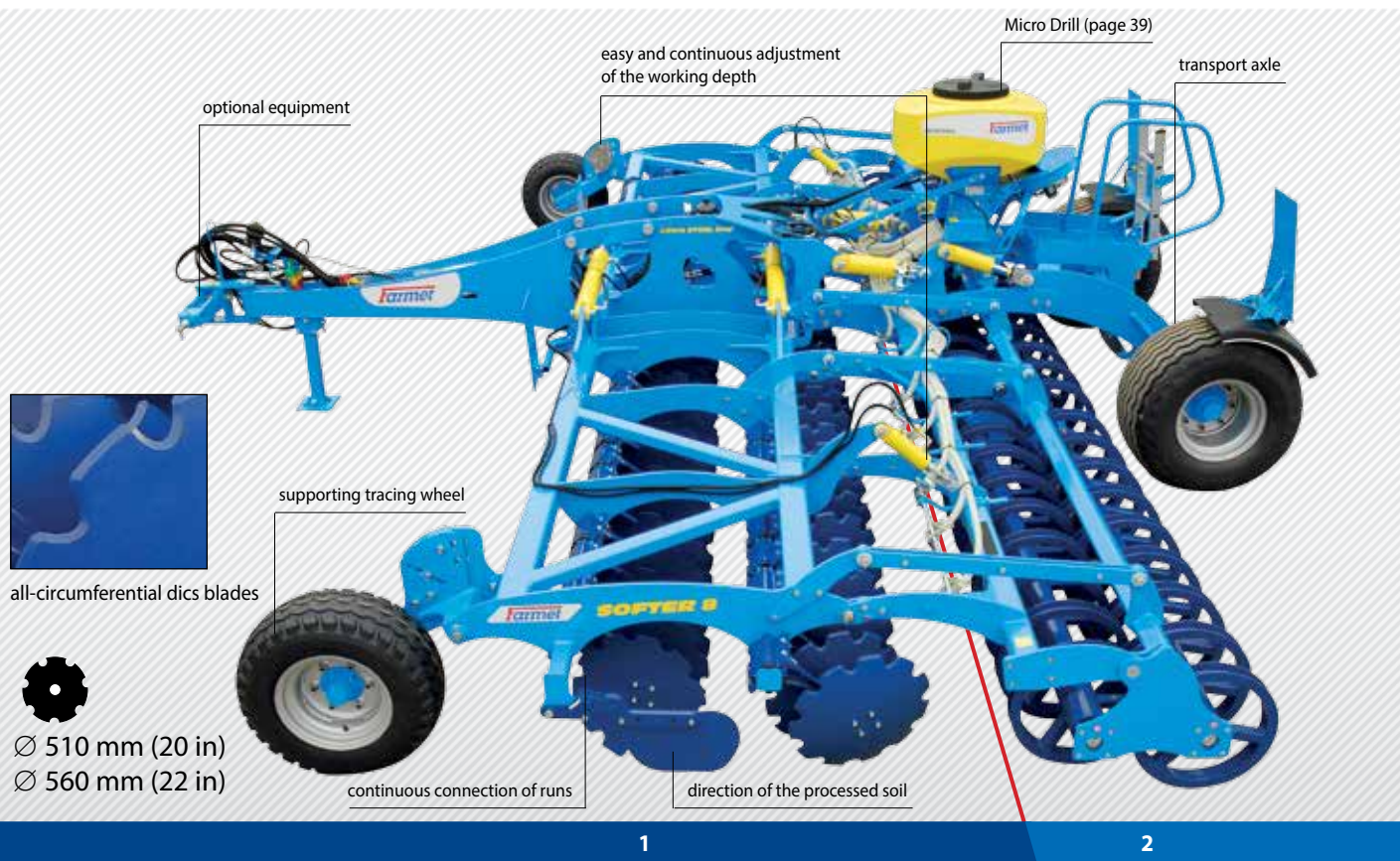

1. Disks with the diameter of 510 mm / 560 mm located in two rows undercut the soil. Working depth is 3,5–12 cm.
2. Clods are crumbled by the rear roller. (Optional rollers, page 39).

**NEW**
**NEW**
**NEW**

Technical parameters	Units	Softer 4 FIX P	Softer 4,5 PS	Softer 5 PS	Softer 6 PS	Softer 8 PS	Softer 9 PS W	Softer 11 PS	Softer 12 PS W	Softer 12,5 PS
Working width	mm / ft	4100 / 13.5	4600 / 15.1	5080 / 16.7	6000 / 19.7	7650 / 25.1	8650 / 28.4	10880 / 35.7	11880 / 39.0	12250
Transport width	mm / ft	4330 / 14.2	3000 / 9.8	3000 / 9.8	3000 / 9.8	3000 / 9.8	4000 / 13.1	3000 / 9.8	4000 / 13.1	3000
Transport height	mm / ft	1600 / 5.3	2650 / 8.7	2900 / 9.5	3370 / 11.0	4000 / 13.1	4000 / 13.1	4000 / 13.1	4000 / 13.1	4000
Total machine length	mm / ft	6675 / 21.9	5740 / 18.8	6675 / 21.9	5740 / 18.8	5960 / 19.6	6850 / 22.5	5960 / 19.6	6520 / 21.4	8200
Working depth	mm / in	35–120 / 1.5–4.5	35–120 / 1.5–4.5	35–120 / 1.5–4.5	35–120 / 1.5–4.5	35–120 / 1.5–4.5	35–120 / 1.5–4.5	35–120 / 1.5–4.5	35–120 / 1.5–4.5	35–120 / 1.5–4.5
Number of ploughshares	pcs	34	38	42	50	62	70	90	98	101
Working performance	ha/h (ac/h)	4.0–6.0 (10–15)	3.6–7 (9–17)	5.0–7.5 (12–19)	6–9 (15–22)	8–12 (20–30)	9.0–13.5 (22–33)	11–17 (27–42)	12.0–18.1 (30–44.5)	12.3–18.4 (30.3–45.3)
Towing vehicle	kW HP	110–160 150–215	120–180 160–240	130–190 175–255	150–225 200–300	200–300 270–405	220–320 295–430	245–370 330–495	280–410 380–550	300–450 400–600
Machine weight	kg / lb.	3600 / 7940	3600 / 7940	4350 / 9590	4500 / 9930	6300 / 13903	7600 / 16758	8860 / 19540	10920 / 24080	13000 / 28665

 More info at [www.farmet.eu](http://www.farmet.eu)



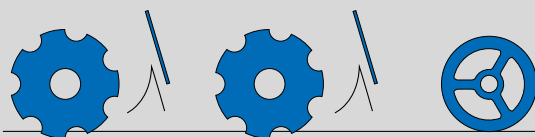

# DISKOMAT

disk plough-harrows

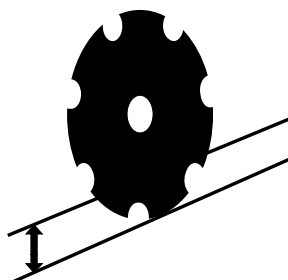

Disk plough-harrow Diskomat is especially suitable for stubble-breaking with intensively mixed stubble and cultivation up to the depth of 18 cm. It incorporates large quantities of organic matter, e.g. corn, organic fertilizer, catch crops or high weed infestation. Intensively prepares the sowing bed with optimum soil compaction. Perfectly undercuts the processed soil profile.

Ø 620 mm (24 in)



50–180 mm (2–7 in)

**10–15 km/h**  
**6–9 mph**

**eXtra STEEL line®**  
ultra high strength steel technology



N

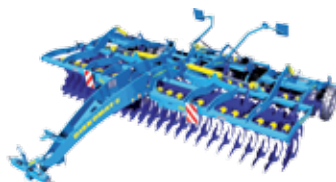

PS

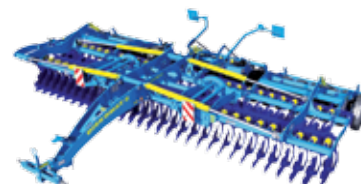

PS



- A great advantage of the conception of the machine is the generally known levelling effect so the disk plough-harrow is also suitable for **pre-sowing soil processing** when emphasis is put on **good levelling of the land** and quality soil processing.
- Disk plough-harrow Diskomat is unique in **the overall construction and design** as well as in the solution of the individual technical nodes and the use of special material technologies. That provides the machine with very **compact dimensions** (mainly for transport on the road network), **very low weight** and its favourable distribution onto the working bodies and particularly very **low maintenance requirements**.
- There are **several types of rear rollers** depending on the soil conditions. The integrated transport axle with braked wheels is a part of the double rubber-tyred roller.
- Great emphasis is put on the overall design and ergonomics of the machine. All adjusting nodes are easily accessible to the operator and meet strict safety requirements. Most controlling elements are solved by hydraulics and can be comfortably regulated directly from the operator's position in the tractor during work.

### High performance and quality of work

- **Work without clogging** due to high framework clearance.
- **Perfect undercut** due to optimized tilt of the disks.
- Gear disks for safe penetration into the soil and intensive mixing.
- **Maintenance-free spring protection** for optimal working angles of the disk.
- **Precise deep guiding** with optimum soil compaction due to support and compaction rollers.



### Robust design

- Each of the disks is separately protected thereby is ensure perfect protection of working units and **high passability for plant residues**.
- Robust placement of the disks ensuring operation of the machine in the most demanding conditions.
- Wide placement of the working units ensuring stability. Resistant and maintenance-free spring protection with high release force.
- **The mounting of working units using replaceable high-strength cases extends the service life of the machine**





# DISKOMAT N

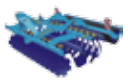
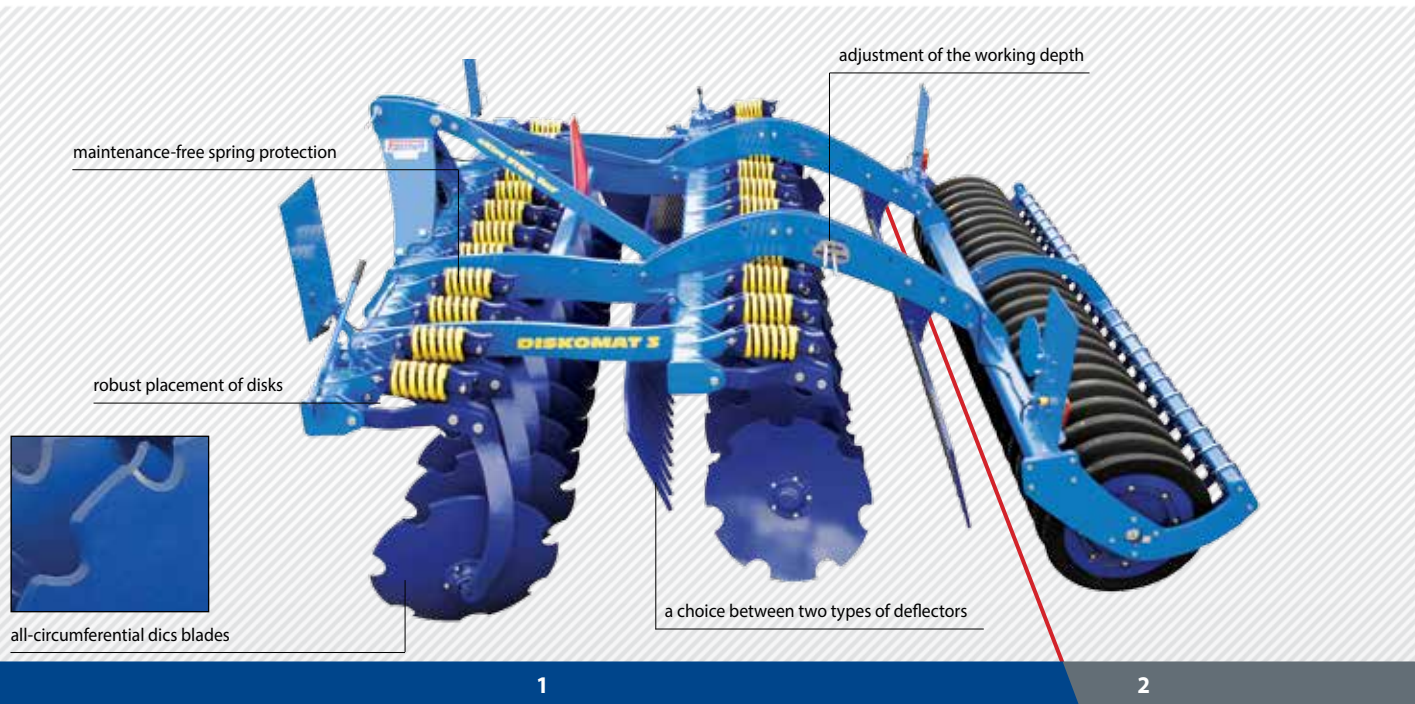

1. Disks with diameter of 620 mm located in two rows will undercut the soil. Working depth is 5–18 cm. Behind each row of disks is a deflector striking down flying clods.
2. Clods are crumbled by the rear roller. (Optional rollers, page 39).

Technical parameters	Units	Diskomat 3 N	Diskomat 3,5 N
Working width	mm / ft	3000 / 9.8	3500 / 11.5
Transport width	mm / ft	3000 / 9.8	3500 / 11.5
Transport height	mm / ft	1600 / 5.3	1600 / 5.3
Total machine length	mm / ft	3300 / 10.8	3300 / 10.8
Working depth	mm / in	50–180 / 2–7	50–180 / 2–7
Number of ploughshares	pcs	12 / 12	14 / 14
Working performance	ha/h (ac/h)	3.0–4.5 (8–11)	2.35–5.25 (6–13)
Towing vehicle	kW / HP	105–158 / 140–165	120–180 / 160–240
Machine weight	kg / lb.	2400 / 5300	2600 / 5750

More info at [www.farmet.eu](http://www.farmet.eu)





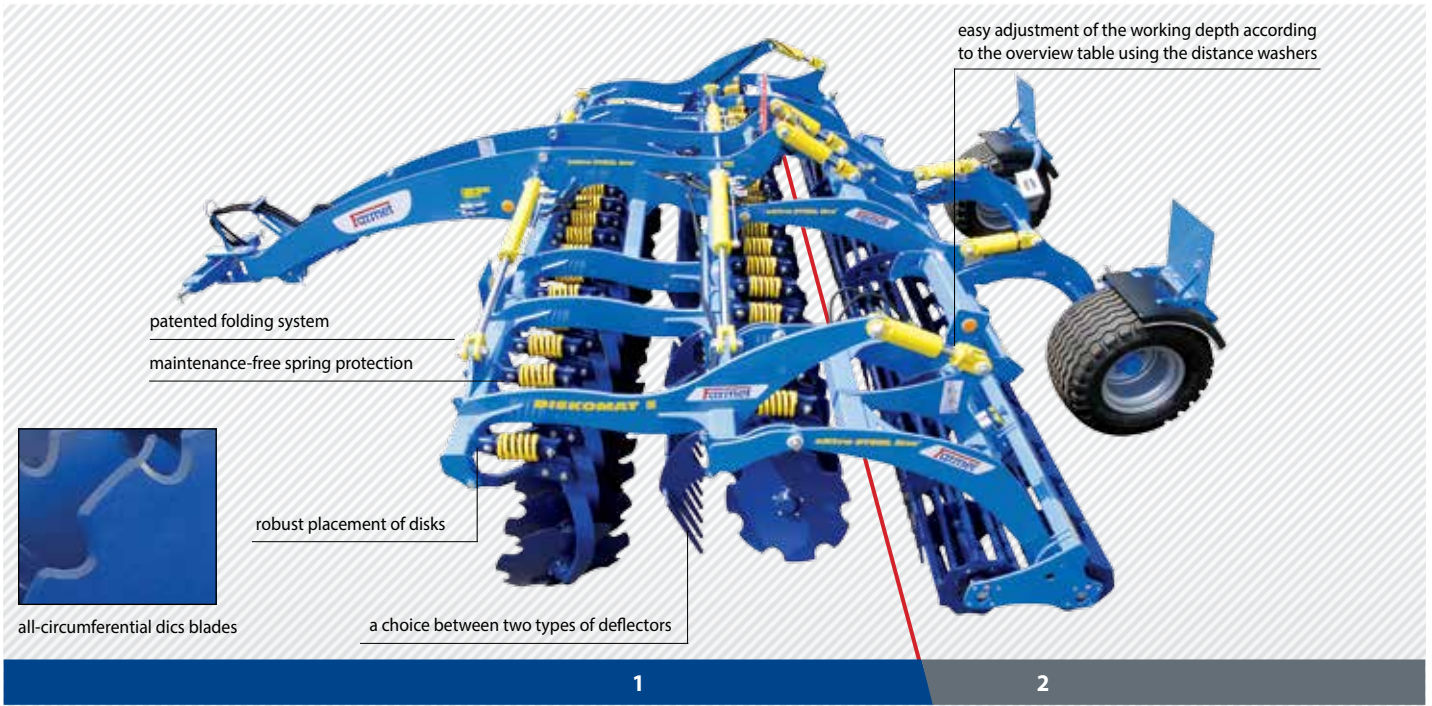

1. Disks with the diameter of 620 mm located in two rows undercut the soil. Working depth is 5–18 cm. Behind each row of disks is a deflector striking down flying clods.
2. Clods are crumbled by the rear roller. (Optional rollers, page 39).



Technical parameters	Jednotky	Diskomat 5 PS	Diskomat 6 PS	Diskomat 8 PS
Working width	mm / ft	5000 / 16.4	6000 / 19.7	7800 / 25.6
Transport width	mm / ft	3000 / 9.8	3000 / 9.8	3000 / 9.8
Transport height	mm / ft	3300 / 10.8	3650 / 12	4000 / 13.1
Total machine length	mm / ft	6600 / 21.7	6600 / 21.7	6600 / 21.7
Working depth	mm / in	50–180 / 2–7	50–180 / 2–7	50–180 / 2–7
Number of ploughshares	pcs	20 / 20	24 / 24	30 / 30
Working performance	ha/h (ac/h)	5.0–8.0 (12–20)	6.0–9.0 (15–22)	8.0–12.0 (20–30)
Towing vehicle	kW / HP	150–220 / 205–300	180–260 / 245–355	240–300 / 325–410
Machine weight	kg / lb.	6200 / 13700	6950 / 15330	8660 / 19100

More info at [www.farmet.eu](http://www.farmet.eu)





# TERRIX TERRIX DUAL

chisel cultivators

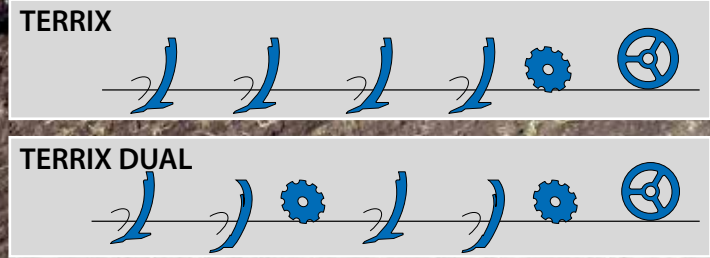

- A four-row tined cultivator with a wide range of application from shallow stubble cultivation to deep soil loosening of up to 35 cm. Overall loosening of the cultivated surface with intense mixing of crop residue. Highly versatile and suitable for all types of soil.
- The **Terrix** chisel cultivator is equipped with four rows of working tines with a spacing of 84 cm in each row and an overall tine spacing of 21 cm. This allows intense overall loosening and cultivation, with the entire soil profile being processed. The release force of each tine is 450 kg, allowing a consistent working depth at the sub surface levels of up to 35 cm. The chisels can be equipped with wings for better lifting during shallow stubble cultivation work. Levelling disks after each row of tines, combined with the rear packer help achieve a level and consolidated surface.

The four-row TERRIX tined cultivators ensure high soil and crop residue mixing, with excellent incorporation and levelling effect. While TERRIX offers excellent soil cultivation, TERRIX DUAL offers gradual deep loosening through the soil layers, achieving an even greater incorporation of trash and soil mixing.

**8–12 km/h**  
**5–7 mph**

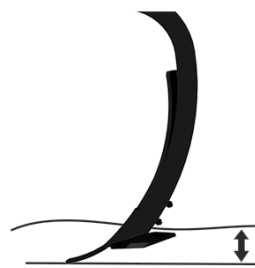

100–350 mm  
(3.9–13.8 in)



TERRIX



TERRIX DUAL



**extra STEEL line**  
ultra high strength steel technology



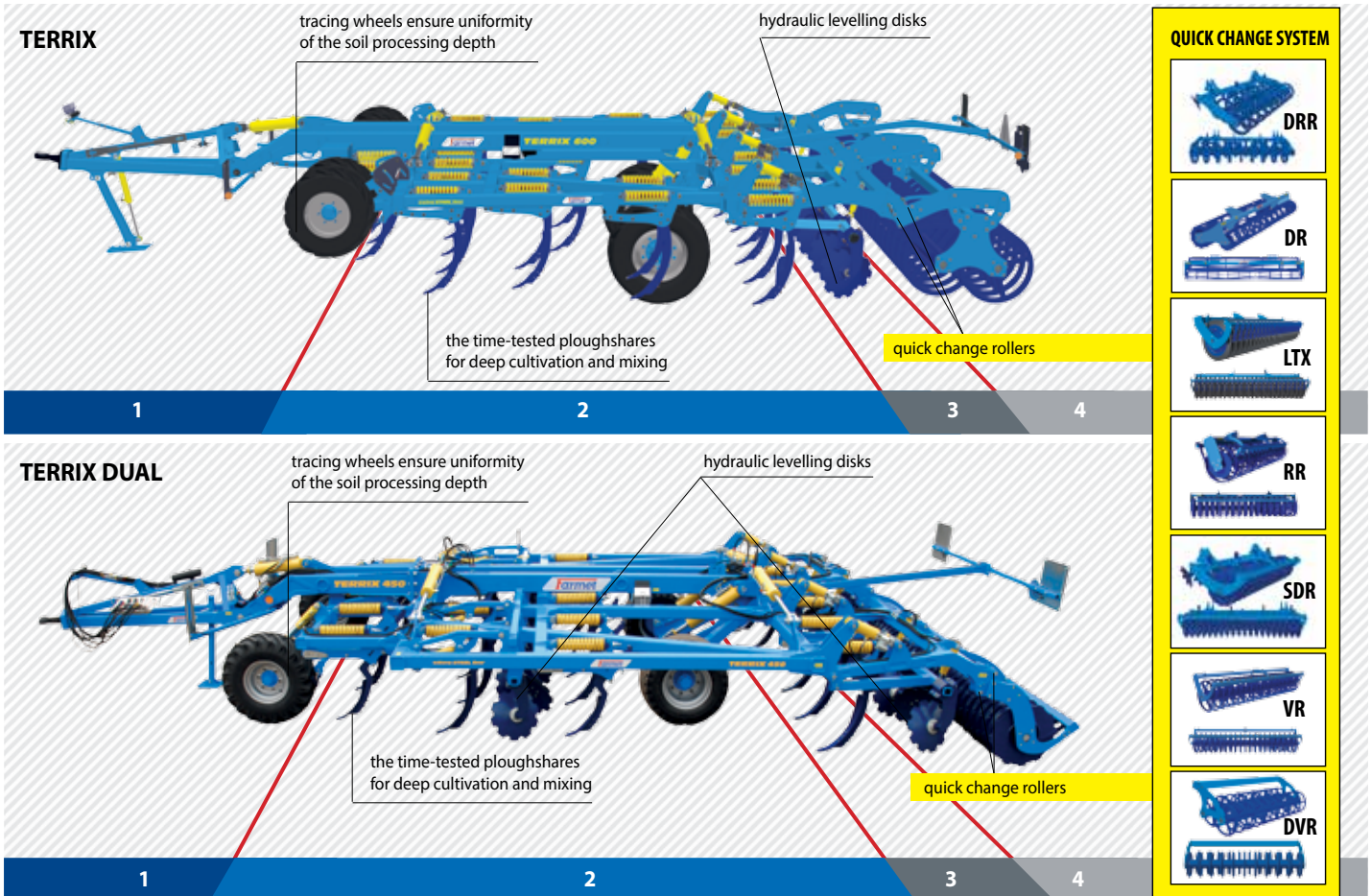

1. Supporting tracing wheels for uniform processing of the soil.
2. Four rows of massive ploughshares for stubble-breaking and deep cultivation up to the depth of 35 cm. (Opt. ploughshares, page 33).
3. Coordination disks for fine structure of the soil on surface.
4. Rear double tyre-packer compacts the soil. It includes transport axle. (Optional rollers, page 39).

**Option of working without the optional rollers and guiding disks.**

- The four-row **TERRIX DUAL** tined cultivator operates on the principle of gradual soil cultivation up to a working depth of 35 cm. This gives a significantly better quality of loosening and a very high, two-level effect of crop residue incorporation. The soil surface is processed both along the entire area and by deeper loosening in a single pass.
- The **Terrix Dual** chisel cultivator is equipped with four rows of working tines with a spacing of 84 cm in each row. Unlike Terrix, the tines are configured in tandem so there is gradual deepening during loosening. This significantly improves the quality of work and reduces the draft requirement. Levelling discs are mounted behind the second and fourth row of tines. The Terrix Dual layout significantly increases the effect of crop residue incorporation when compared with conventional cultivators and can be an alternative to conventional tillage methods. It works especially well in heavier soils with a large quantity of crop residue.

### High performance and quality of work

- **Great solution for all types of soils** but especially good for heavy soils.
- **High permeability** of soil and crop residue.
- High level of crop residue mixing and incorporation.
- **Deep overall (Terrix) or progressive (Terrix Dual)** loosening with minimal clod information.

### Robust design

- **High-strength materials** are used on key elements of the frame for durability
- **Durable and maintenance-free protection** of loosening tines, combined with a high release force of 450kg
- Time-tested share design using an **extremely high-strength and abrasion-resistant steels with added carbide tips**



Technical parameters	Units	TERRIX 450 PS	TERRIX 600 PS	TERRIX DUAL 450 PS	TERRIX DUAL 600 PS
Working width	mm / ft	4500 / 14.8	6000 / 19.7	4300 / 14.1	6000 / 19.7
Transport width	mm / ft	3000 / 9.8	3000 / 9.8	3000 / 9.8	3000 / 9.8
Transport height	mm / ft	3340 / 11.0	4000 / 13.1	3340 / 11.0	4000 / 13.1
Total machine length	mm / ft	10500 / 34.5	10500 / 34.5	10500 / 34.5	10500 / 34.5
Working depth	mm / in	100–350 / 3.9–13.8	100–350 / 3.9–13.8	100–350 / 3.9–13.8	100–350 / 3.9–13.8
Number of ploughshares	pcs	22	30	22	30
Working performance	ha/h (ac/h)	3.6–5.4 / 9–13.4	4.8–7.2 / 12–17.8	3.6–5.4 / 9–13.4	4.8–7.2 / 12–17.8
Towing vehicle	kW / HP	225–350 / 300–450	350–460 / 470–630	225–350 / 300–450	350–460 / 470–630
Machine weight	kg / lb.	7300 / 16100	8000 / 17640	7300 / 16100	8000 / 17640

More info at [www.farmet.eu](http://www.farmet.eu)



# TRITON

combined cultivators

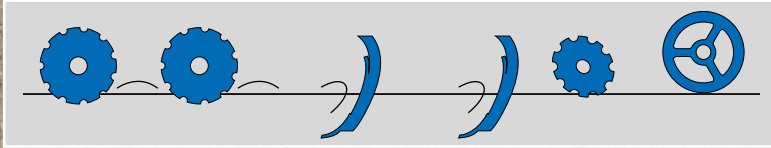

DEEP SOIL PROCESSING

- The combined disk-and- tine cultivator is ideal for working through heavier soils with a large quantity of crop residue. Trash is evenly mixed into the overall processed soil layer while the soil is loosened and worked by the different working elements.
- The Triton combination cultivator is equipped with two rows of disks of 510 mm or 560 mm diameter with maintenance-free overload protection. The discs have a working depth of 12 cm and have excellent crop residue mixing properties. The following two rows of heavy duty tines have a wide spacing of 42 cm and loosen the soil up to 35 cm depth, while allowing excellent water penetration through to the subsurface. The final row of levelling disks combined with the rear packer help to achieve a level and consolidated surface

The TRITON combination cultivator provides the advantages of a disc stubble cultivator and chisel tined cultivator in a single pass. The result is efficient cutting and mixing of crop residue into processed soil with deeper aeration providing excellent water penetration through the soil.

**8–12 km/h**  
**5–7 mph**

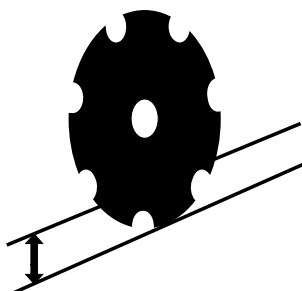

Ø 510 mm (20 in) 35–120 mm (1.4–4.8 in)  
Ø 560 mm (22 in) 35–120 mm (1.4–4.8 in)



100–350 mm  
(3.9–13.8 in)





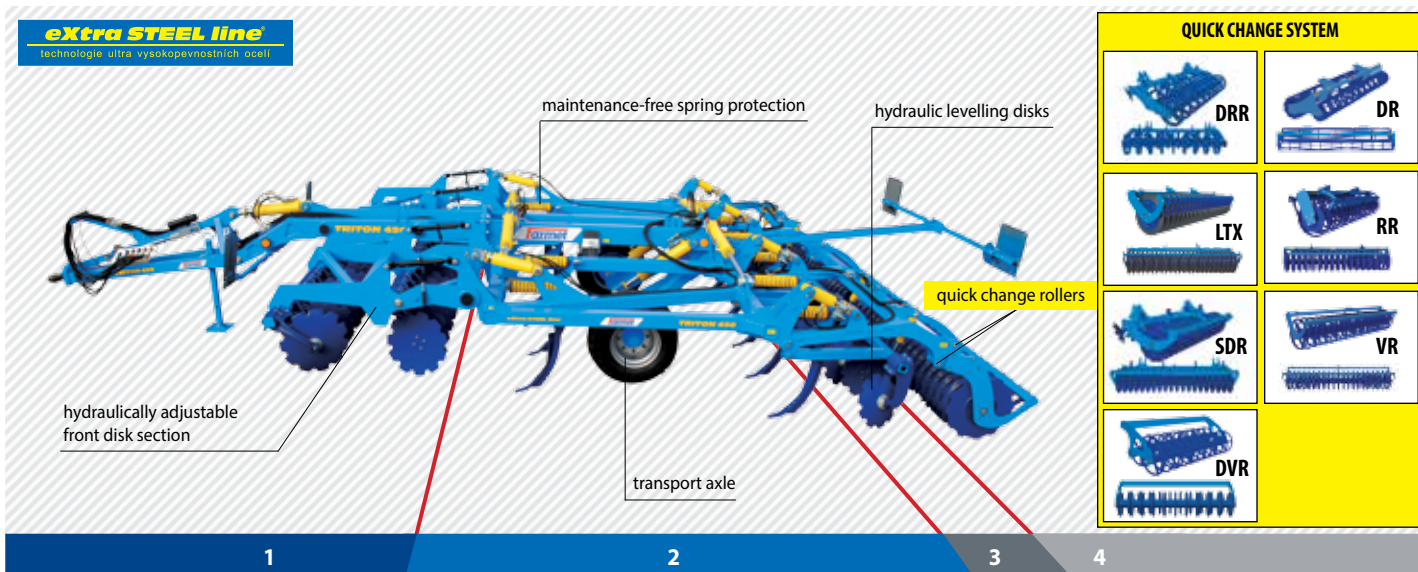

1. Disks with the diameter of 510 / 560 mm located in two rows undercut the soil.
2. Massive ploughshares situated in 2 rows ensure quality loosening of the soil and incorporation of plant residues. (Optional ploughshares, page 33).
3. Coordination disks for fine structure of the soil on surface.
4. Back roller provides good recompaction of the soil, crumbling of clods and levelling of the area surface. (Optional rollers, page 39).

**Option of working without the optional rollers and guiding disks.**

Technical parameters	Units	Triton 450 PS	Triton 600 PS
Working width	mm / ft	4300 / 14.1	5970 / 19.6
Transport width	mm / ft	3000 / 9.8	3000 / 9.8
Transport height	mm / ft	3400 / 11.2	4000 / 13.1
Total machine length	mm / ft	10000 / 32.8	10000 / 32.8
Working depth	mm / in	100–350 / 3.9–13.8	100–350 / 3.9–13.8
Number of ploughshares / disks	pcs	11 / 38	15 / 42
Working performance	ha/h (ac/h)	3.6–5.4 / 8.9–13.4	4.8–7.2 / 12–17.8
Towing vehicle	kW / HP	210–320 / 290–440	335–465 / 460–640
Machine weight	kg / lb.	7200 / 15840	8800 / 19360

More info at [www.farmet.eu](http://www.farmet.eu)

### High performance and quality of work

- Excellent solution for heavy soils.
- **Low draft resistance** in work.
- **High performance** mixing of soil and crop residue.
- **Efficient cutting** and even mixing of crop residue into the processed soil layers.
- Deep soil loosening with minimal clod formation.

### Robust design

- **High-strength materials** are used on key elements of the frame for durability.
- Durable and maintenance-free protection of the cultivating disks.
- Durable and maintenance-free protection of loosening tines, combined with a high release force of 450 kg.
- Time-tested share design using an **extremely high-strength and abrasion-resistant steels** with added carbide tips.





# ***TRIOLENT*** ***DUOLENT***

chisel cultivators





TRIOLENT

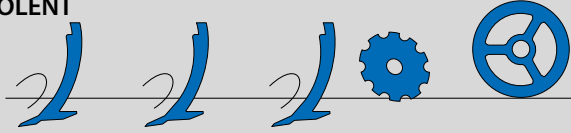

DUOLENT

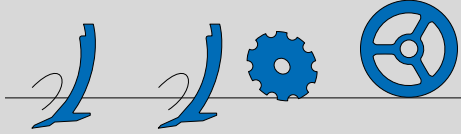

Chisel cultivators Trioilent / Duolent are especially suitable for full-area stubble-breaking with intensive mixing effect. The soil is processed **up to the depth of 35 cm** and thus can replace ploughing. Excellently incorporates plant residues into the soil.

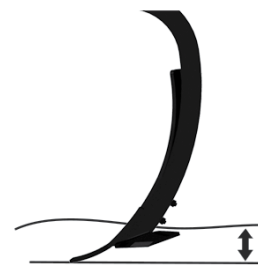

60–350 mm (2,4–13,8 in)

**8–12 km/h**  
**5–7 mph**

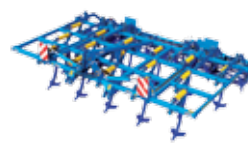

Trioilent NS



Trioilent PS

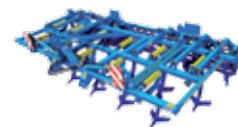

Duolent NS

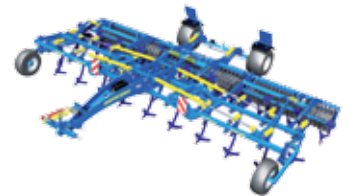

Duolent PS

**eXtra STEEL line®**  
ultra high strength steel technology



# TRIOLENT/DUOLENT N/NS

- Chisel cultivator is suitable for both common stubble breaking and cultivation, and for deepening to the depth greater than usual depth of ploughing.
- Chisel cultivator is equipped with three rows (Triolent), two rows (Duolent) of working units with the ploughshare pitch of 290 mm (420 mm), which ensures quality loosening of the soil and incorporation of plant residues with relatively low traction resistance. The ploughshares are equipped with spring protection with release force of 450 kg and enable to work to the depth of 35 cm. For work to the depth of 20 cm ploughshares can be equipped with winglets for full-area undercut. For greater depths it works better without winglets since the traction resistance is significantly reduced. The quality of processing is not deteriorated.

## High performance and quality of work

- **Low traction resistance and excellent mixing of the soil** due to the optimized design of ploughshares.
- **Excellent permeability** for plant residues.
- The spiral shape of the upper part of ploughshares for controlled flow of the soil.
- **Maintenance-free working members** fitted with plates of cemented carbides for minimal wear.
- Chisels with winglets for full-area undercut up to the depth of 20 cm. **Ideal for incorporation of a large quantity of plant residues.**

## Robust design

- **High-strength refined materials** used for crucial nodes to ensure long service life.
- Resistant and maintenance-free spring protection with high release force of 450 kg.
- The time-tested ploughshares are made of high-strength abrasion resistant steels.



## DUOLENT





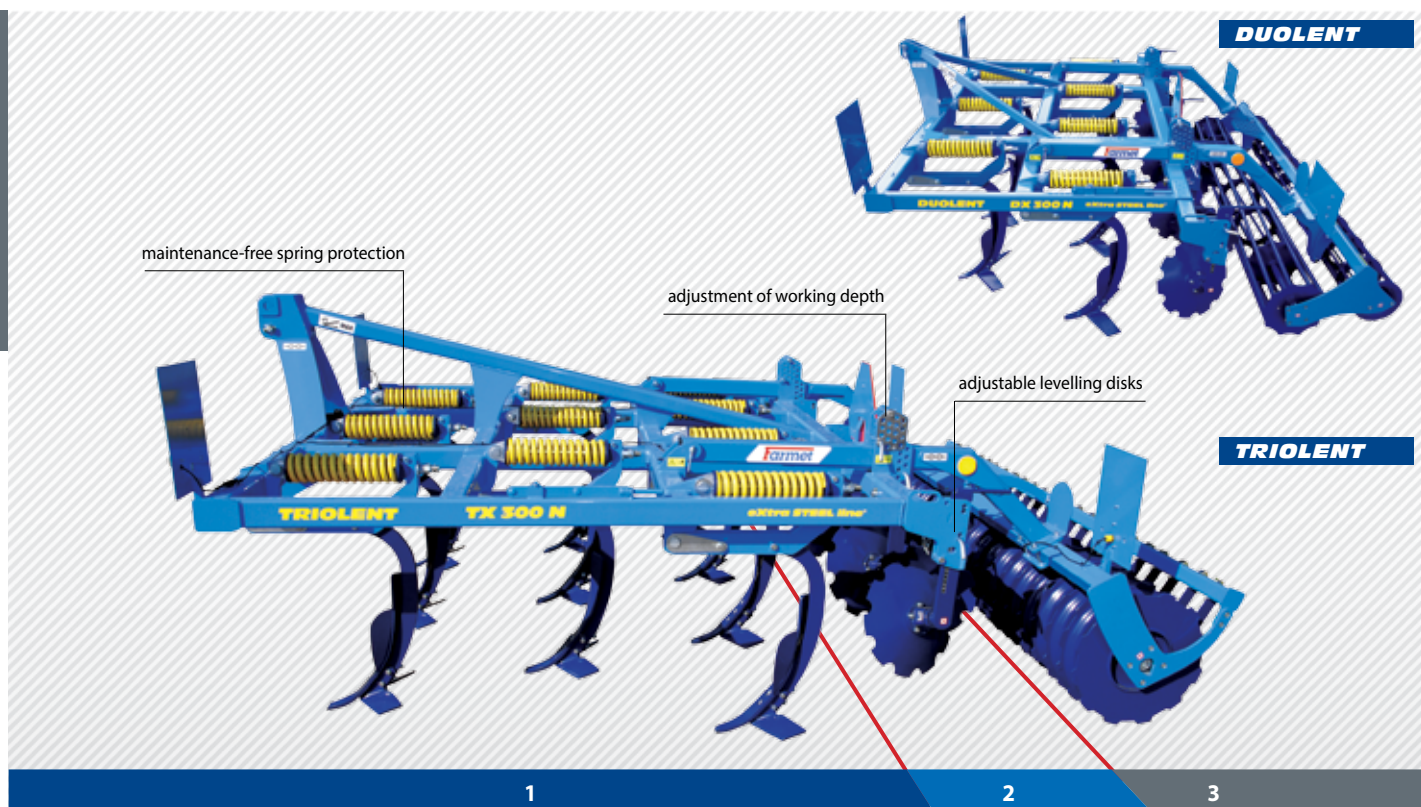

1. Massive ploughshares situated in 3 rows (Triolent), 2 rows (Duolent) ensure quality loosening of the soil and incorporation of plant residues. (Optional ploughshares, page 33).
2. Coordination disks for fine structure of the soil on surface.
3. Back roller provides good recompaction of the soil, crumbling of clods and levelling of the area surface. (Optional rollers, page 39).

Technical parameters	Units	Triolent TX 300 N	Triolent TX 350 N	Triolent TX 380 NS	Triolent TX 470 NS
Working width	mm / ft	3000 / 9.8	3500 / 11.5	3800 / 12.5	4700 / 15.4
Transport width	mm / ft	3000 / 9.8	3500 / 11.5	2300 / 7.6	3000 / 9.8
Transport height	mm / ft	1400 / 4.6	1400 / 4.6	2500 / 8.2	2500 / 8.2
Total machine length	mm / ft	4060 / 13.3	4060 / 13.3	4050 / 13.3	4050 / 13.3
Working depth	mm / in	60–350 / 2.4–13.8	60–350 / 2.4–13.8	60–350 / 2.4–13.8	60–350 / 2.4–13.8
Number of ploughshares	pcs	10	13	13	16
Working performance	ha/h (ac/h)	2.4–3.6 (6–8.4)	2.8–4.2 (7–10.4)	3.1–4.5 (7.7–11)	3.7–5.6 (9–13.9)
Towing vehicle	kW / HP	110–165 / 150–225	120–175 / 160–240	125–190 / 170–255	150–220 / 200–300
Machine weight	kg / lb.	1680 / 3704	1920 / 4233	2655 / 5853	3010 / 6636

More info at [www.farmet.eu](http://www.farmet.eu)



Technical parameters	Units	Duolent DX 210 N	Duolent DX 300 N	Duolent DX 350 N	Duolent DX 380 NS	Duolent DX 460 NS	Duolent DX 550 NS
Working width	mm / ft	2100 / 6.9	3000 / 9.8	3500 / 11.5	3800 / 12.5	4600 / 15	5500 / 18
Transport width	mm / ft	2230 / 7.3	3000 / 9.8	3500 / 11.5	2200 / 7.2	3000 / 9.8	3000 / 9.8
Transport height	mm / ft	1400 / 5	1400 / 5	1400 / 5	2500 / 8.2	2500 / 8.2	2500 / 8.2
Total machine length	mm / ft	3350 / 11	3350 / 11	3350 / 11	3350 / 11	3350 / 11	3350 / 11
Working depth	mm / in	60–350 / 2.4–13.8	60–350 / 2.4–13.8	60–350 / 2.4–13.8	60–350 / 2.4–13.8	60–350 / 2.4–13.8	60–350 / 2.4–13.8
Number of ploughshares	pcs	5	7	9	9	11	13
Working performance	ha/h (ac/h)	1.7–2.5 (4.2–6.2)	2.4–3.6 (6–8.9)	2.8–4.2 (7–10.4)	3.1–4.5 (7.7–11)	3.7–5.5 (9–13.6)	4.4–6.6 (10.9–16.3)
Towing vehicle	kW / HP	65–110 / 90–135	90–135 / 120–180	105–160 / 140–210	120–180 / 160–240	150–225 / 200–300	180–270 / 240–360
Machine weight	kg / lb.	1060 / 2337	1375 / 3031	1585 / 3494	2220 / 4894	2515 / 5545	2870 / 6327

More info at [www.farmet.eu](http://www.farmet.eu)





# TRIOLENT/DUOLENT PS

- Chisel cultivator is suitable for both common stubble breaking and cultivation, and for deepening to the depth greater than usual depth of ploughing.
- Chisel cultivator is equipped with three rows (Triolent), two rows (Duolent) of working members with the ploughshare pitch of 290 mm (420 mm), which ensures quality loosening of the soil and incorporation of plant residues with relatively **low traction resistance**. The ploughshares are equipped with spring protection with release force of 450 kg and enable to work to the depth of 35 cm. For work to the depth of 20 cm ploughshares can be equipped with winglets for **full-area undercut**. For greater depths it works better without winglets since the traction resistance is significantly reduced. The quality of processing is not deteriorated.

## High performance and quality of work

- **Low traction resistance** and excellent mixing of the soil due to the optimized design of ploughshares.
- **Excellent permeability** for plant residues.
- The spiral shape of the upper part of ploughshares for controlled flow of the soil.
- **Maintenance-free working members** fitted with plates of cemented carbides for minimal wear.
- Chisels with winglets for full-area undercut up to the depth of 20 cm. **Ideal for incorporation of a large quantity of plant residues.**

## Robust design

- **High-strength refined materials** used for crucial nodes to ensure long service life.
- Resistant and maintenance-free spring protection with high release force of 450 kg.
- The time-tested ploughshares are made of high-strength abrasion resistant steels.



## TRIOLENT





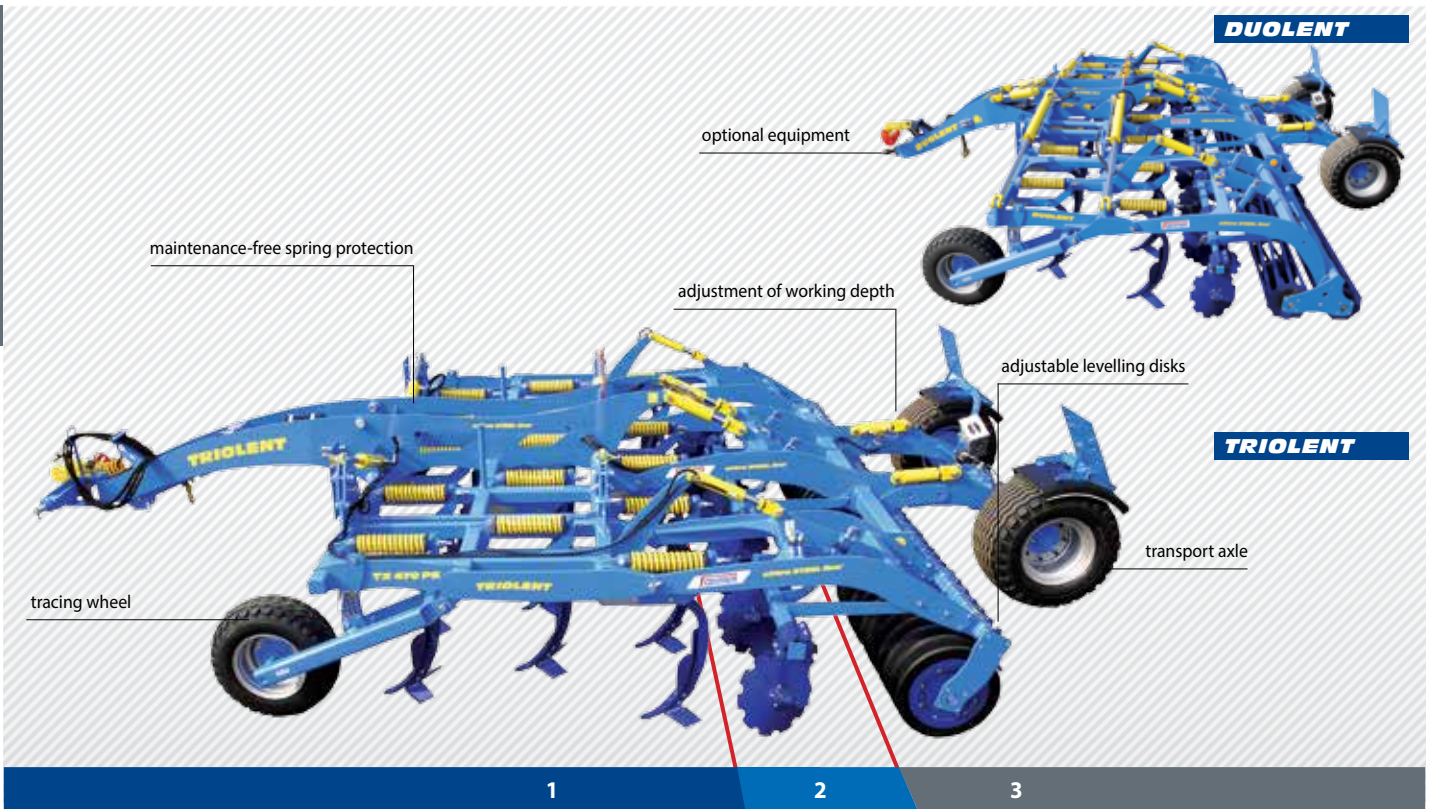

1. Massive ploughshares situated in 3 rows (Triolent), 2 rows (Duolent) ensure quality loosening of the soil and incorporation of plant residues. (Optional ploughshares, page 33).
2. Coordination disks for fine structure of the soil on surface.
3. Back roller provides good recompaction of the soil, crumbling of clods and levelling of the area surface. (Optional rollers, page 39).



Technical parameters	Units	Triolent TX 470 PS	Triolent TX 600 PS	Triolent TX 800 PS	Duolent DX 460 PS	Duolent DX 600 PS	Duolent DX 800 PS
Working width	mm / ft	4700 / 15.4	6200 / 20.3	7900 / 26	4600 / 15	6200 / 20.3	7900 / 26
Transport width	mm / ft	3000 / 9.8	3000 / 9.8	3000 / 9.8	3000 / 9.8	3000 / 9.8	3000 / 9.8
Transport height	mm / ft	2800 / 9.2	3300 / 10.8	4000 / 13	2800 / 9.2	3300 / 10.8	4000 / 13
Total machine length	mm / ft	7495 / 24.6	7495 / 24.6	7495 / 24.6	6800 / 22.3	6762 / 25.5	6762 / 25.5
Working depth	mm / in	60–350 / 2.4–13.8	60–350 / 2.4–13.8	60–350 / 2.4–13.8	60–350 / 2.4–13.8	60–350 / 2.4–13.8	60–350 / 2.4–13.8
Number of ploughshares	ks	16	19	25	11	15	19
Working performance	ha/h (ac/h)	3.7–5.6 (9.2–13.8)	4.8–7.2 (11.8–17.8)	6.4–9.6 (15.8–23.7)	3.7–5.5 (9.2–13.5)	4.8–7.2 (11.8–17.8)	6.4–9.6 (15.8–23.7)
Towing vehicle	kW / HP	150–220 / 200–300	245–370 / 330–500	295–440 / 400–600	150–225 / 200–305	220–330 / 300–450	265–400 / 360–540
Machine weight	kg / lb.	4620 / 10185	6750 / 14881	7550 / 16645	4080 / 9000	6050 / 13338	6795 / 14980



More info at [www.farmet.eu](http://www.farmet.eu)





# FERTIS

cultivators and fertilizer applicators

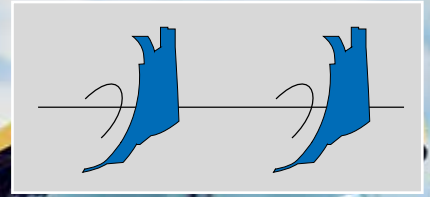

DEEP SOIL PROCESSING



Cultivator and fertilizer applicator Fertis is especially suitable for **deep row cultivation and aeration of soils – strip till technology up to the depth of 35 cm.** It also ensures targeted applications of supply fertilization in two depths (to the seeds and to the roots) – due to which it is possible to decrease the applied amount of fertilizers while maintaining the required yields.



1. Chisel ploughshares for additional fertilization and cultivation in two rows. (Optional ploughshares, page 31).



Technical parameters	Units	Fertis 4,5
Working width	mm / ft	4500 / 14.8
Transport width	mm / ft	3000 / 9.8
Transport height	mm / ft	2800 / 9
Total machine length	mm / ft	3000 / 9.8
Working depth	mm / in	100–350 / 4–13.8
Number of ploughshares	pcs	13
Working performance	ha/h (ac/h)	2.0–4.5 (5–11)
Towing vehicle	kW / HP	180–270 / 240–360
Machine weight	kg / lb.	2860 / 6305

**8–12 km/h**  
**5–7 mph**

**extra STEEL line**  
ultra high strength steel technology



# STRIP-TILL

track cultivators

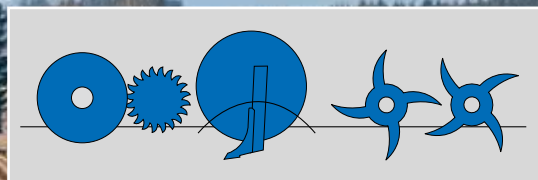

8–12 km/h  
5–7 mph

**eXtra STEEL line**  
ultra high strength steel technology

The Strip-Till track cultivator is suitable for soil tillage where soil is processed in strips with the spacing of 70 or 75 cm and depth of up to 35 cm with the option to apply fertiliser at two depth levels. The strip till method is most suitable for wide-row crops as it prevents the loss of moisture from soil and has an anti-erosion effect.

Ploughshare width	150 mm (5.9 in)
Towing vehicle	22–33 kW/ploughshare 30–45 HP/ploughshare



Ploughshare width	50 mm (2 in)
Towing vehicle	15–22 kW/ploughshare 20–30 HP/ploughshare

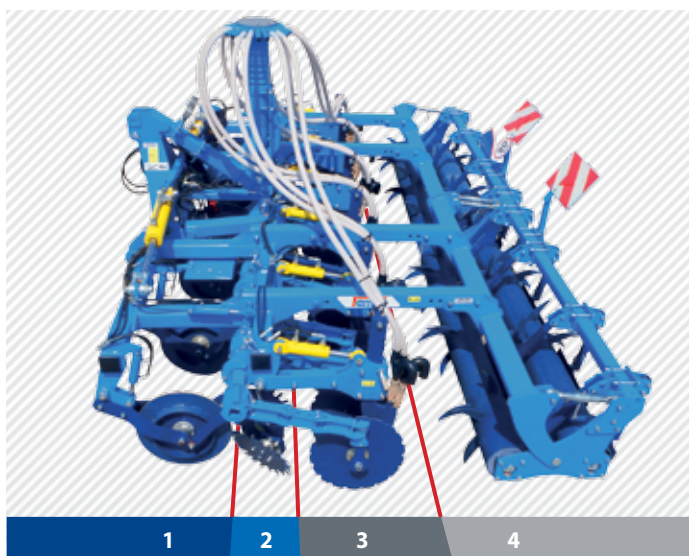

1. The front disc with a vertical setting angle cuts through the crop residue layer.
2. The spreading disk spreads crop residue into the inter-row.
3. The massive shares loosen soil in the strip up to the depth of 35 cm.
4. The rear double spiked roller crushes clods and compacts the top layer of the loosened row.

Technical parameters	Units	Strip-Till 3	Strip-Till 4,5	Strip-Till 6
Working width	mm / ft	3000 / 9.8	4500 / 14.8	6000 / 19.7
Transport width	mm / ft	3000 / 9.8	3000 / 9.8	3000 / 9.8
Transport height	mm / ft	1800 / 5.9	2600 / 8.5	3350 / 11
Total machine length	mm / ft	3000 / 9.8	3050 / 10	3050 / 10
Working depth	mm / in	200–350 / 8–13.8	200–350 / 8–13.8	200–350 / 8–13.8
Number of ploughshares	pcs	4	6	8
Ploughshare spacing	mm / in	750 (700) / 29.5 (27.5)	750 (700) / 29.5 (27.5)	750 (700) / 29.5 (27.5)
Working performance	ha/h (ac/h)	2,4–3,6 / 5.9–8.9	3,6–5,4 / 8.9–13.3	4,8–7,2 / 11.9–17.8
Machine weight	kg / lb.	1650 / 3638	2300 / 5071	2750 / 6064

More info at [www.farmet.eu](http://www.farmet.eu)



# STRENGTHENED CARBIDE PLOUGHSHARES

# CARBIDE

**NEW**

## 75 MULTICARBIDE PRO

### Extra Long Life

New massive forged shares with an extended service life and efficient protection against wear and tear thanks to the strong carbide plates.

**Up to 5 times longer service life**

Catalog No.	4017938
Share width	75 mm
Share body hardness	up to 58 HRC
Widia plate hardness	up to 92 HRA

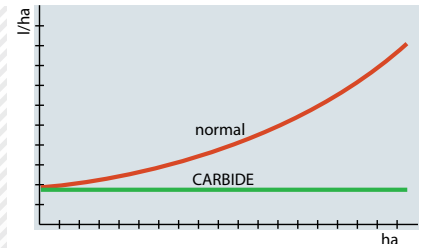

Reinforced share body

massive forged share

strong carbide plates



**TERRIX**



**TERRIX DUAL**



**TRITON**

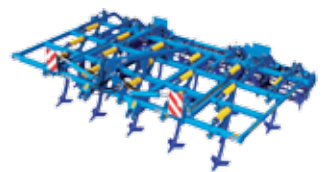

**TRIOLENT**

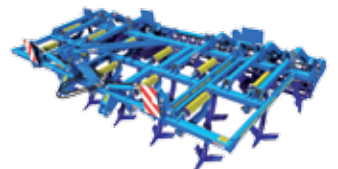

**DUOLENT**



**FERTIS**





Possibility to combine various shares in a single machine.

### CARBIDE



+ 100–200 %



- 15 %

### MULTICARBIDE



+ 150–400 %



- 15 %

### MULTICARBIDE PRO



+ 200–500 %



- 15 %

Effective working depth 6–30 cm

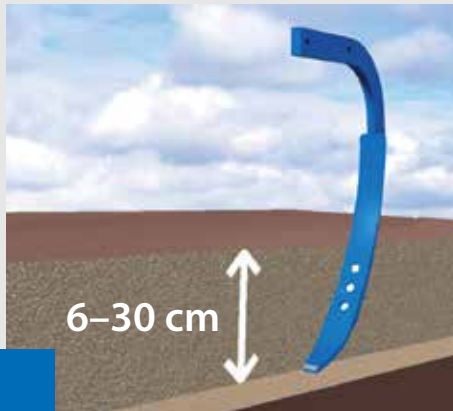

Catalog No.	4005271
Share width	75 mm
Share thickness	15 mm
Share body hardness	up to 55 HRC
Widia plate hardness	up to 92 HRA



Standard

**extra STEEL line**  
with high strength steel technology

75 CARBIDE

Catalog No.	4017627
Share width	75 mm
Share body hardness	up to 58 HRC
Widia plate hardness	up to 92 HRA



Long Life  
Massive forged share

75 MULTICARBIDE

Effective working depth 15–35 cm

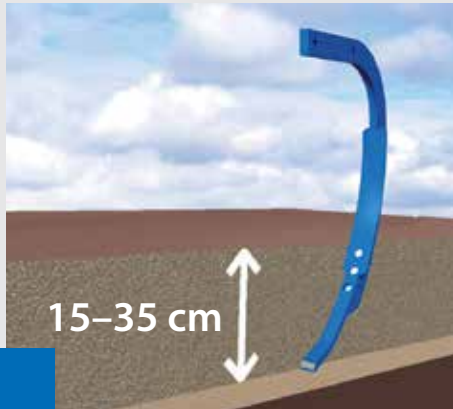

40 MULTICARBIDE narrowed shares (40 mm) to reduce tractive resistance and efficient protection against wear and tear thanks to carbide plates.

Catalog No.	4010983
Share width	40 mm
Share thickness	20 mm
Share body hardness	up to 55 HRC
Widia plate hardness	up to 92 HRA



40 MULTICARBIDE

Effective working depth 15–38 cm

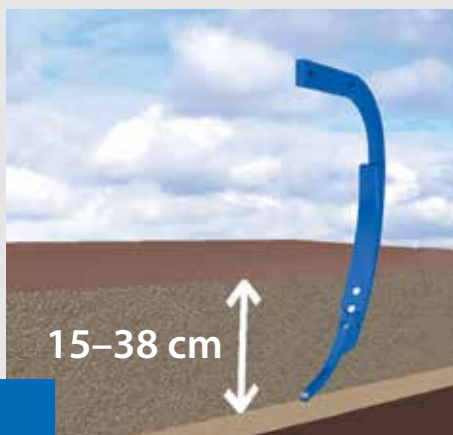

20 MULTICARBIDE narrow and elongated shares (20 mm) to reduce tractive resistance and to increase the depth of soil cultivation up to 38 cm with efficient protection against wear and tear thanks to carbide plates.

Catalog No.	4010984
Share width	20 mm
Share thickness	20 mm
Share body hardness	up to 55 HRC
Widia plate hardness	up to 92 HRA



20 MULTICARBIDE



# DIGGER

deep cultivators

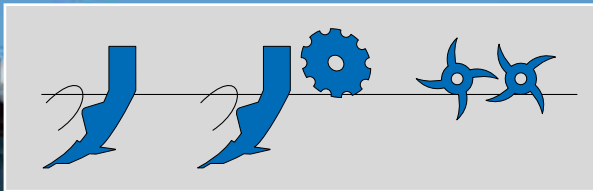

**eXtra STEEL line®**

ultra high strength steel technology



Digger is suitable especially as equivalent to **standard ploughing at higher capacity and lower operating costs**. It is also suitable for deep cultivation of impermeable layer of soil, levelling and fine processing of clods. It significantly improves absorption of compacted and wet soils and revitalizes headlands after harvest. It is also used for loosening of subsoil layer without risk of mixing with the biologically inactive soil.

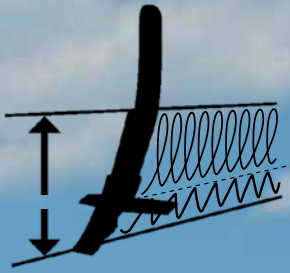

250–500 mm



### DIGGER BASIC VERSIONS

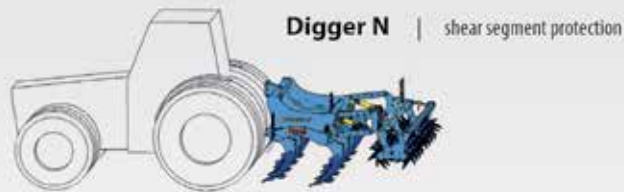

**8–12 km/h**  
**5–7 mph**



# DIGGER

- Performs deep loosening of impermeable subsoil layer, cultivation of topsoil with incorporation of plant residues and levelling together with fine processing of clods as well. The soil is ready for sowing, e.g. with sowing combination, without other operations. The processing quality **substitutes ploughing at higher performance and lower costs.**
- **Massive construction of the frame** and working units is determined for processing of soil **up to the depth of 50 cm.** The soil processing is performed differentially according to the processing depth. Compacted subsoil layer is disintegrated and loosened without mixing with upper layers and water regime is restored. A special ploughshare with reinforced standard and adjustable height of winglets separating the depth by processing the production layer of soil with mixing from the lower part with cultivation only.
- Each farmer appreciates independent **hydraulic control of working depth** for each row of the ploughs directly from the tractor. It is a very practical solution. In adverse weather conditions, e.g. in a wet part of the field, the operator can work only with one row. In case of congestion, the machine is simply cleared by lifting one row up.

## High performance and quality of work

- The new ploughshare design has a **very low traction resistance** and enables a high **working speed up to 12 km/h.**
- Ploughshares smoothly penetrate the soil and **the soil is cultivated without mixing it with subsoil layer**, so-called biologically inactive soil.
- Possibility of **lifting one row of the ploughshares under heavy conditions** such as marshes, headlands or when ploughing roads after harvest.
- Two rows of ploughshares provide a very good stability of the machine and **precise depth guiding** without the need to use tracing wheels. The high frame clearance of 750 mm provides **excellent passability.**
- The ploughshares with winglets incorporate plant residues very well and the levelling disks together with the double spiked roller perfectly level furrows.

## Robust design

- **High-strength refined materials** used for crucial nodes to ensure long service life.
- The tips of ploughshares are fitted with plates of **cemented carbides** for long service life, low wear and to maintain optimum geometry.
- The ploughshares are hydraulically protected by a release force at the tip of 1100 kg or you can choose the variant with mechanical protection.

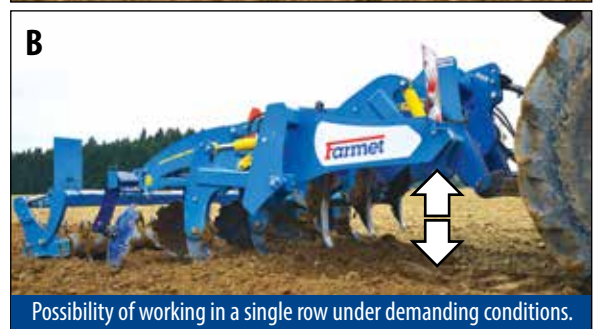

Possibility of working in a single row under demanding conditions.





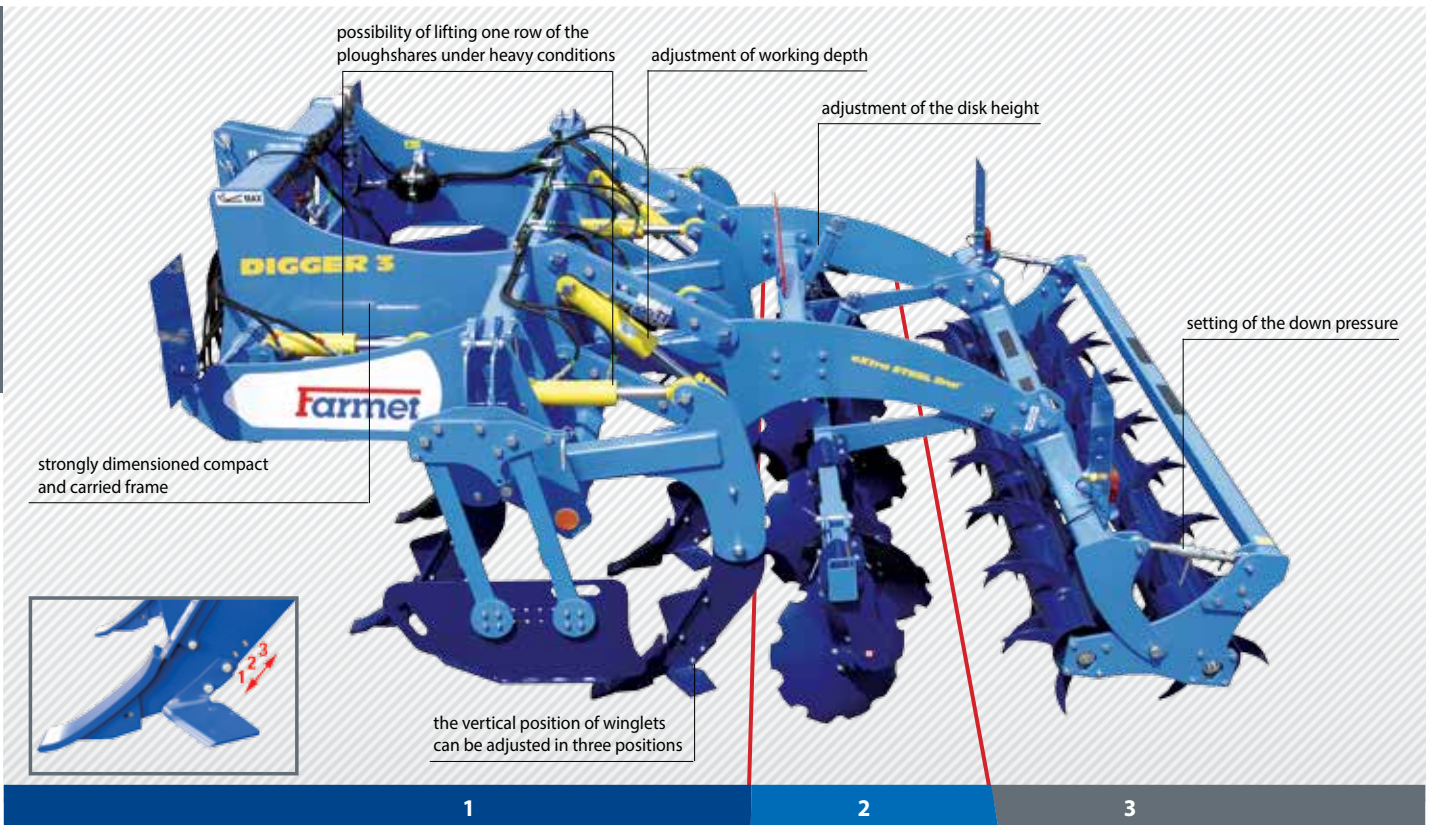

1. Massive ploughshares situated in 2 rows for deep cultivation 25–50 cm.
2. The levelling disks for striking down flying clods and partial cutting of clods on the surface.

3. The rear double spiked roller for crumbling of clods (Page 39).

Technical parameters	Units	NEW		NEW		NEW		NEW	
		Digger 3 N / Digger 3 N Fert+	Digger 4 N / Digger 4 N Fert+	Digger 3 N Fert+ Compact	Digger 4 N Fert+ Compact	Digger 3 N-P Fert+ Compact	Digger 4 N-P Fert+ Compact	Digger 3 P FW	Digger 4 P FW
Working width	mm / ft	2900 / 9.5	3900 / 12.8	2900 / 9.5	3900 / 12.8	2990 / 9.8	2990 / 9.8	2900 / 9.5	3900 / 12.8
Transport width	mm / ft	2990 / 9.8	3990 / 13.1	2990 / 9.8	3990 / 13.1	2990 / 9.8	3990 / 13.1	2990 / 9.8	3990 / 13.1
Transport height	mm / ft	1790 / 5.9	1790 / 5.9	3500 / 11.4	3500 / 11.4	3500 / 11.4	3500 / 11.4	2790 / 9.2	2790 / 9.2
Total machine length	mm / ft	4000 / 13	4000 / 13	4125 / 13.5	4125 / 13.5	7720 / 25.3	7720 / 25.3	10980 / 36	10980 / 36
Working depth	mm / in	250–500/10–20	250–500/10–20	250–500/10–20	250–500/10–20	250–500/10–20	250–500/10–20	250–500/10–20	250–500/10–20
Number of ploughshares	pcs	7	9	7	9	7	9	7	9
Working performance	ha/h	2.4–3.6	3.1–4.7	2.4–3.6	3.1–4.7	2.4–3.6	3.1–4.7	2.4–3.6	3.1–4.7
	ac/h	6–9	7.7–11.4	6–9	7.7–11.4	6–9	7.7–11.4	6–9	7.7–11.4
Towing vehicle	kW	180–270	240–360	180–270	290–435	220–330	265–400	220–330	265–400
	HP	240–360	330–450	240–360	400–540	300–450	360–540	300–450	360–540
Machine weight	kg	2800 / 2860	3700 / 3760	3460	4600	6900–7500	7900–8700	5150–5750	5850–6650
	lb.	6180 / 6310	8160 / 8290	7630	10140	15210–16540	17420–19190	11360–12680	12900–14670

More info at [www.farmet.eu](http://www.farmet.eu)

## DIGGER 75 MULTICARBIDE PRO

New massive forged shares with an extended service life and efficient protection against wear and tear thanks to the strong carbide plates.

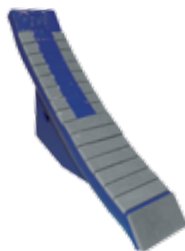

### DIGGER FERT+ COMPACT

up to 2000 l



### DIGGER FERT+ & MONSUN MF

MONSUN MF  
up to 1700 l



Application of fertiliser at two levels.



# KRTEK

deep cultivators

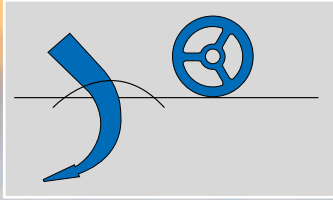

Krtek is especially suitable for deep cultivation of compacted and impermeable layer of soil. It significantly improves absorption of compacted and wet soil. Loosening of subsoil layer is performed without risk of mixing of biologically inactive soil with topsoil.

8–12 km/h  
5–7 mph

**eXtra STEEL line**  
ultra high strength steel technology



1

1. Ploughshares in one row for deep cultivation up to the depth of 60 cm.

- The deep cultivator is designed for work in all soil conditions which is enabled by hydraulic automatic protection.
- The time-tested ploughshares with possibility of powerful automatic hydraulic protection or alternatively with maintenance-free fixed pull rods.
- Supporting tracing wheels for more precise deep guiding of the machine.



Technical parameters	Units	Krtek DG 3	Krtek DG 5	Krtek DG 7
Working width	mm / ft	2690 / 8.8	2990 / 9.8	4400 / 14.4
Transport width	mm / ft	2700 / 8.8	3000 / 9.8	4450 / 14.6
Transport height	mm / ft	1980 / 6.5	1980 / 6.5	1980 / 6.5
Total machine length	mm / ft	1330 / 4.4	1380 / 4.5	1380 / 4.5
Working depth	mm / in	300–600 / 12–24	300–600 / 12–24	300–600 / 12–24
Nr. of ploughshares	pcs	3	5	7
Working performance	ha/h (ac/h)	0.8–1.0 (2–2.5)	1.0–1.4 (2.5–3.5)	2.8–4.2 (6.9–10.4)
Towing vehicle	kW / HP	110–165 / 150–225	180–270 / 245–360	250–380 / 335–510
Machine weight	kg / lb.	880 / 1940	1170 / 2579	1750 / 3859

More info at [www.farmet.eu](http://www.farmet.eu)

300–600 mm  
12–24 in

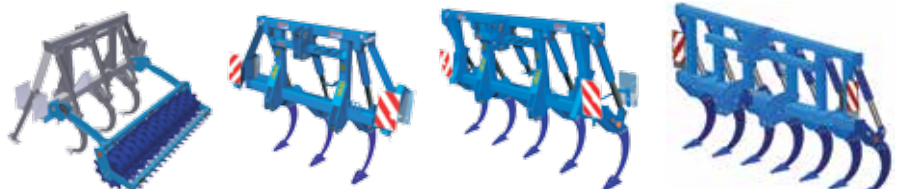
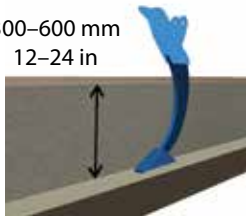



**1 TR**

	mm	510
	kg/m	90

**2 DR**

	mm	400/350 (PS) 400/300 (NS)
	kg/m	120

**3 RR**

	mm	520
	kg/m	160

**4 DRR**

	mm	4.1 540/540	4.2 680/680
	kg/m	195	340

**NOVINKA**

**5 LTX**

	mm	586
	kg/m	200

**6 SDR**

	mm	580
	kg/m	220

**7 DP**

	mm	820/520
	kg/m	190

**8 DSR**

	mm	570
	kg/m	175

**9 CR**

	mm	400
	kg/m	180

**10 VR**

	mm	600
	kg/m	175

**11 DVR**

	mm	680/680
	kg/m	290

**NOVINKA**

**12 MICRO DRILL**

	1	2	3	4.1	4.2	5	6	7	8	9	10	11	12
Fantom NS	×	×	×				×				×		×
Fantom CLASSIC	×					×	×						
Fantom PRO	×			×			×		×				
Terrix / Terrix Dual PS		×	×		×	×	×				×	×	×
Triton PS		×	×		×	×	×				×	×	×
Triolent NS / Duolent NS	×	×	×			×	×			×	×		×
Triolent PS / Duolent PS		×	×	×		×	×				×		×
Digger							×		×				
Krtek							×						
Softer NS	×	×	×			×	×				×		×
Softer PS	×	×	×	×	11PS	×	×				×		×
Diskomat N	×	×	×			×	×				×		×
Diskomat PS		×	×	×		×	×	×			×		×
Strip Till													×
Falcon PRO / COMPACT													×



# KOMPAKTOMAT

presowing combinators

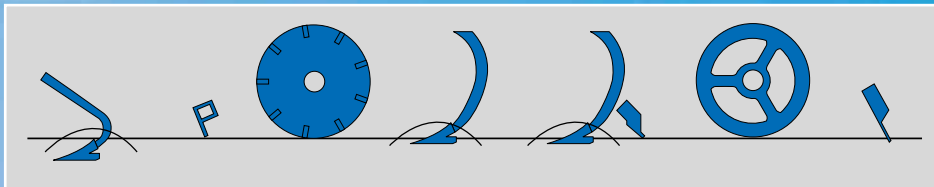





Presowing combinators Kompaktomat are time-tested machines designed for **presowing preparation of the soil after ploughing**. During one run the soil is perfectly processed to the state required for sowing of crops.

The advantage of the machine is **excellent levelling of the surface**, fine crumbling of clods and **formation of well-compacted sowing bed**. The land is perfectly levelled also due to smoothing harrows that can level and spread even high unevenness.



0–100 mm (0–4 in)

**10–14 km/h**  
**6–8 mph**



N



NS



P



PS

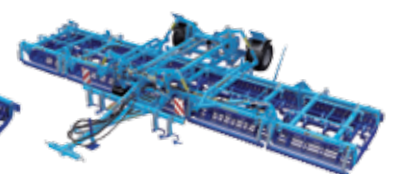

PS

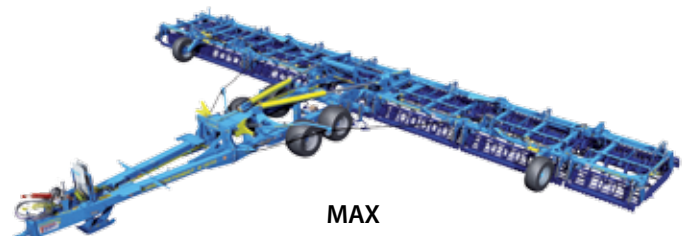

MAX

**extra STEEL line**  
ultra high strength steel technology



### High performance and quality of work

- 7 operations performed during one run.
- High working speed up to 14 km/h.
- Excellent recompaction and restoration of soil capillarity ensuring equal introduction.
- Precise adjustment of the depth of the ploughshare ensures precise preparation of the sowing bed for each crop.
- Automatic protection of ploughshares ensures trouble-free operation.
- Excellent levelling effect of field unevenness.

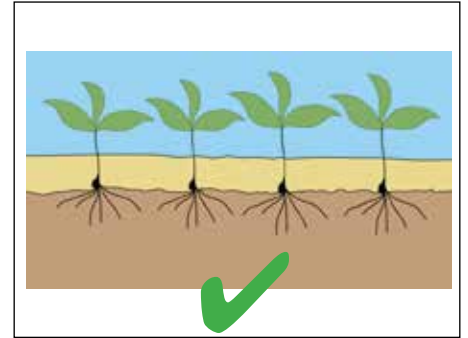
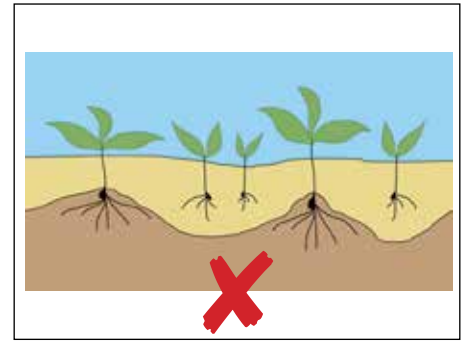

### Robust design

- High-strength refined materials used for crucial nodes to ensure long service life. Heavily designed frame.
- The robust front smoothing harrow ensuring removal of upper layers of topsoil.
- Automatically unprotected ploughshares.
- The control elements of the presowing combinator are designed in order to achieve maximum safety of workers. Simple but quality construction with minimum maintenance requirements.

AL



CF



AP



AL 4

NEW





- Due to **high working speed**, **high working performance** can be achieved even with lower working span of the Kompaktomat machine. A key consideration is that due to its well-considered design and favourable weight Kompaktomat can prepare the soil after ploughing during one run, whereas the soil is processed not only on the surface, but in the whole horizon.
- During the run Kompaktomat performs **several working operations**, during which the surface of the soil is levelled and compacted to the depth. In the cultivated soil capillarity is restored and in the required depth the sowing bed is formed. The clods are finely crumbled. To achieve an ideal level, Kompaktomat is equipped with three smoothing harrows. The front leveller is located in front of the roller so that the machine can level and spread even high unevenness.
- Optionally, the combinator can be equipped with **hydraulic adjustment of depth of the share section and hydraulic adjustment of the front leveller**.

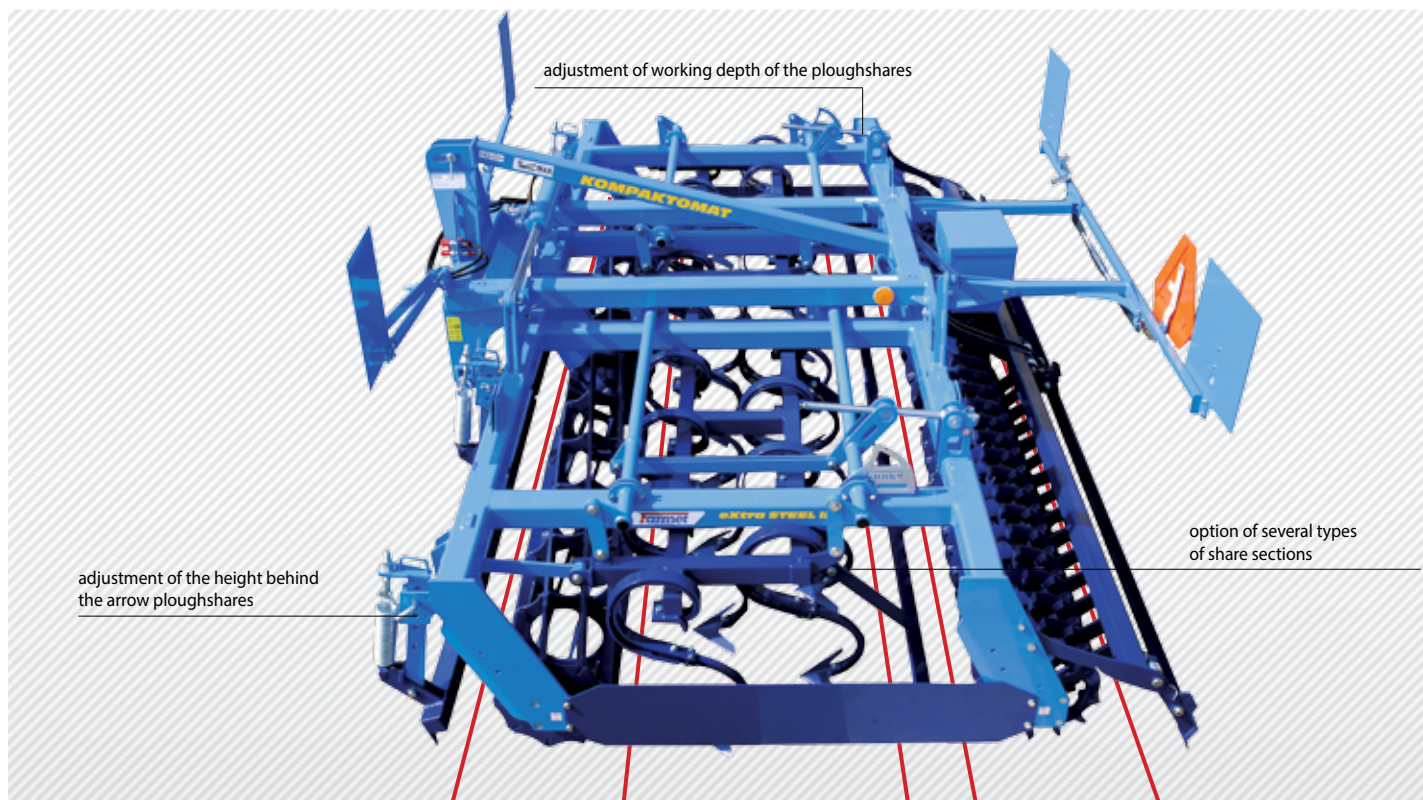

1 2 3 4 5

1. Front smoothing harrow for coarse levelling of the surface.
2. Front roller for rough crumbling of clods.
3. Share working section undercuts and cultivates the soil.
4. Central smoothing harrow levels the cultivated soil and the soil is directed below the rear roller.
5. The rear roller for fine soil processing
6. The rear smoothing harrow levels the surface.

Technical parameters	Units	Kompaktomat K 250 N	Kompaktomat K 300 N	Kompaktomat K 400 NS	Kompaktomat K 500 NS	Kompaktomat K 600 NS
Working width	mm / ft	2580 / 8.5	3000 / 9.8	4000 / 13	5000 / 16.4	6000 / 19.7
Transport width	mm / ft	2580 / 8.5	3000 / 9.8	3000 / 9.8	3000 / 9.8	3000 / 9.8
Total machine length	mm / ft	2640 / 8.6	2640 / 8.6	2930 / 9.6	3200 / 10.5	3200 / 10.5
Working depth	mm / in	0-100 / 0-4	0-100 / 0-4	0-100 / 0-4	0-100 / 0-4	0-100 / 0-4
Number of ploughshares AL/CF/AP	pcs	11 / 26 / 11	13 / 30 / 12	18 / 39 / 16	23 / 49 / 23	27 / 59 / 24
Working performance	ha/h (ac/h)	2.0-3.0 (5-7.5)	2.2-3.2 (5.5-8)	3.0-4.0 (7.4-10)	5.0-6.0 (12.4-14.8)	6.0-7.2 (14.8-17.8)
Towing vehicle	kW / HP	55 / 75	70 / 95	90 / 125	120 / 165	130 / 180
Machine weight	kg / lb.	1155 / 2546	1510 / 3329	2670 / 5886	3150 / 6946	3500 / 7718



More info at [www.farmet.eu](http://www.farmet.eu)





# KOMPAKTOMAT P/PS

- Half-carried machines are offered with the working span from 3 m to 9.85 m. Wide range of working spans covers both small farmers with small tractors and large agricultural holdings equipped with powerful tractors.
- During the run Kompaktomat performs **several working operations**, during which the surface of the soil is levelled and compacted to the depth. In the cultivated soil capillarity is restored and in the required depth the sowing bed is formed.
- Optionally the combinator can be equipped with **hydraulic adjustment of depth of the share section and hydraulic adjustment of the front leveller**.
- Half-carried machines can also be equipped with the rear three-point linkage of category 2 or 3, where **additional crumbling crosskill rollers can be aggregated**. These rollers are suitable especially for summer when hard dry clods must be intensively crumbled. Aggregation of the sowing machine and formation of productive sowing combination is another possibility. (Page 49 and 71).





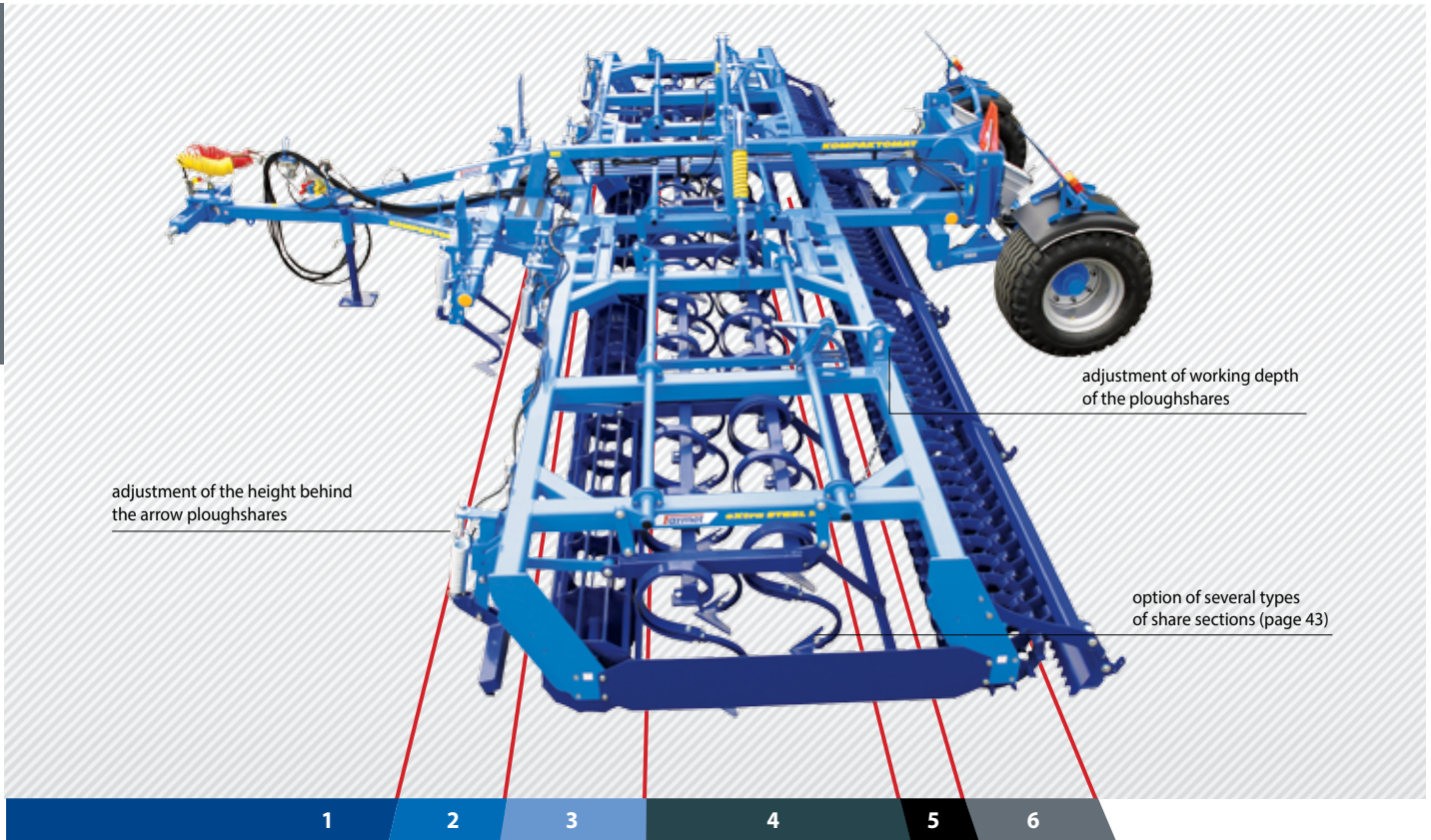

1. Tractor trail cultivators for lifting of the compacted soil.
2. Front smoothing harrow for coarse levelling of the surface.
3. Front roller for rough crumbling of clods.
4. Share working section undercuts and cultivates the soil.
5. Central smoothing harrow levels the cultivated soil and the soil is directed below the rear roller.
6. The rear roller for fine soil processing
7. The rear smoothing harrow levels the surface.

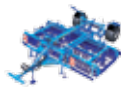

Technical parameters	Units	Kompaktomat K 300 P	Kompaktomat K 400 PS	Kompaktomat K 450 PS	Kompaktomat K 500 PS	Kompaktomat K 600 PS	Kompaktomat K 700 PS	Kompaktomat K 800 PS	Kompaktomat K 1000 PS
Working width	mm / ft	3000 / 9.8	4000 / 13.1	4500 / 14.8	5000 / 16.4	6000 / 19.7	7000 / 23	8000 / 26.3	9850 / 32.3
Transport width	mm / ft	3000 / 9.8	3000 / 9.8	3000 / 9.8	3000 / 9.8	3000 / 9.8	3000 / 9.8	3000 / 9.8	3000 / 9.8
Transport height	mm / ft	1650 / 5.5	2670 / 8.7	3030 / 9.9	2790 / 9.1	3230 / 10.6	3830 / 12.6	4220 / 13.9	4190 / 13.8
Total machine length	mm / ft	5965 / 19.6	5965 / 19.6	5965 / 19.8	6105 / 22	6105 / 22	6105 / 22	6105 / 22	6660 / 24
Working depth	mm / in	0-100 / 0-4	0-100 / 0-4	0-100 / 0-4	0-100 / 0-4	0-100 / 0-4	0-100 / 0-4	0-100 / 0-4	0-100 / 0-4
Number of ploughshares AL/CF/AP	pcs	13 / 30 / 12	18 / 39 / 16	20 / 47 / 20	23 / 49 / 23	27 / 59 / 24	31 / 69 / 31	35 / 77 / 32	43 / 91 / 38
Working performance	ha/h (ac/h)	2.2-3.2 (5.5-8)	3.0-4.0 (7.4-10)	3.5-4.5 (8.6-11)	3.0-5.0 (7.4-12.4)	3.5-6.0 (8.6-14.8)	4.5-7.0 (11-17)	5.5-8.0 (13.6-19.8)	8.5-10.0 (21-24.7)
Towing vehicle	kW / HP	70 / 95	90 / 125	110 / 150	120 / 165	130 / 180	150 / 205	160 / 220	180 / 245
Machine weight	kg / lb.	2360 / 5203	3010 / 6636	3340 / 7363	4025 / 8874	4360 / 9612	4960 / 10935	5345 / 11784	6920 / 15256

More info at [www.farmet.eu](http://www.farmet.eu)





# KOMPAKTOMAT MAX

- The wide span variant of the Kompaktomat machine is manufactured in the working width of 12.5 m and 15.7 m. It is designed for large agricultural holdings equipped with tractors with power up to 600 HP.
- During the run Kompaktomat performs several working operations, during which the surface of the soil is levelled and compacted to the depth. In the cultivated soil capillarity is restored and in the required depth the sowing bed is formed. The clods are finely crumbled. To achieve an ideal level, Kompaktomat is equipped with three smoothing harrows. The front leveller is located in front of the roller so that the machine can level and spread even high unevenness.
- Optionally the combinator can be equipped with hydraulic adjustment of depth of the share section and hydraulic adjustment of the front leveller.





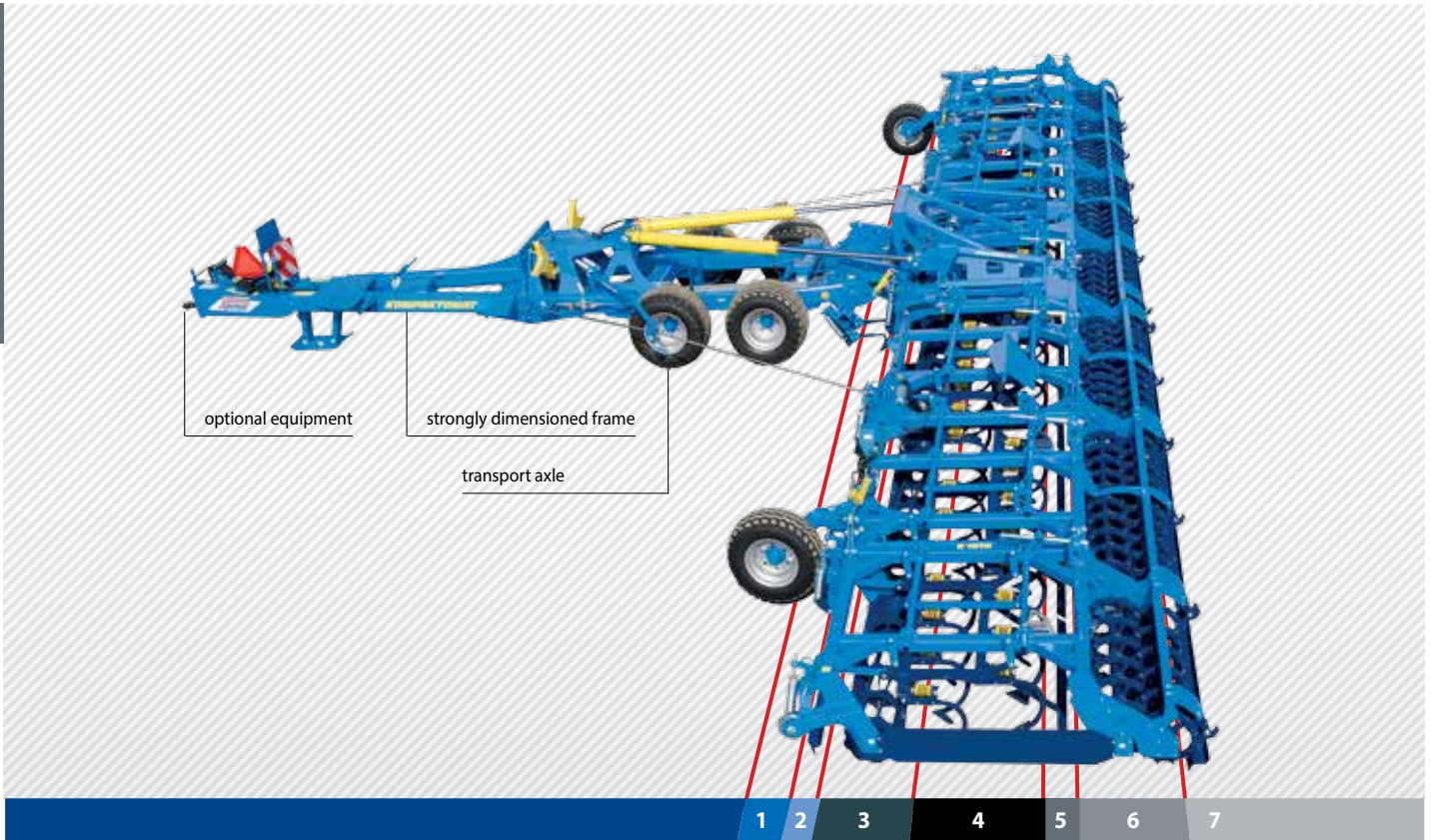

1. Tractor trail cultivators for lifting of the compacted soil.
2. Front smoothing harrow for coarse levelling of the surface.
3. Front roller for rough crumbling of clods.
4. Share working section undercuts and cultivates the soil.
5. Central smoothing harrow levels the cultivated soil and the soil is directed below the rear roller.
6. The rear roller for fine soil processing
7. The rear smoothing harrow levels the surface.



Technical parameters	Units	Kompaktomat K 1250 MAX	Kompaktomat K 1570 MAX
Working width	mm / ft	12500 / 41	15700 / 51.5
Transport width	mm / ft	3000 / 9.8	3000 / 9.8
Transport height	mm / ft	3500 / 11.5	3500 / 11.5
Total machine length	mm / ft	9550 / 31.3	9550 / 31.3
Working depth	mm / in	0-100 / 0-4	0-100 / 0-4
Number of ploughshares AL/CF/AP	pcs	53 / 119 / 53	67 / 149 / 67
Working performance	ha/h (ac/h)	12.0-15.0 (29.6-37)	13.0-20.0 (32.1-49.4)
Towing vehicle	kW / HP	120 / 165	180 / 245
Machine weight	kg / lb.	10500 / 23149	12500 / 27558

More info at [www.farmet.eu](http://www.farmet.eu)





# ROLLERS

1 BR

	mm	400
	kg/m	60

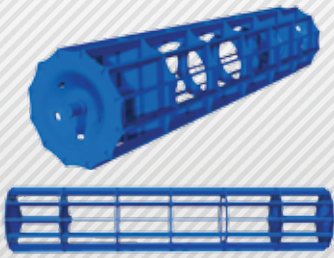

2 SB

	mm	400
	kg/m	60

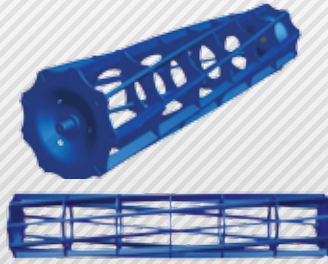

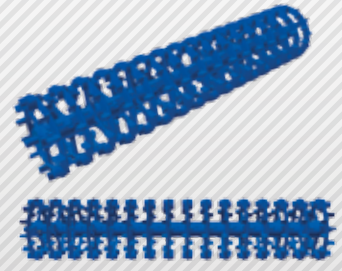

3 CR

	mm	400
	kg/m	170



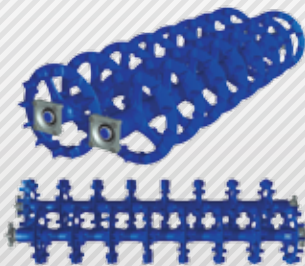

4 DCR

	mm	400
	kg/m	202



5 RR

	mm	400
	kg/m	115



PRESOWING PREPARATION

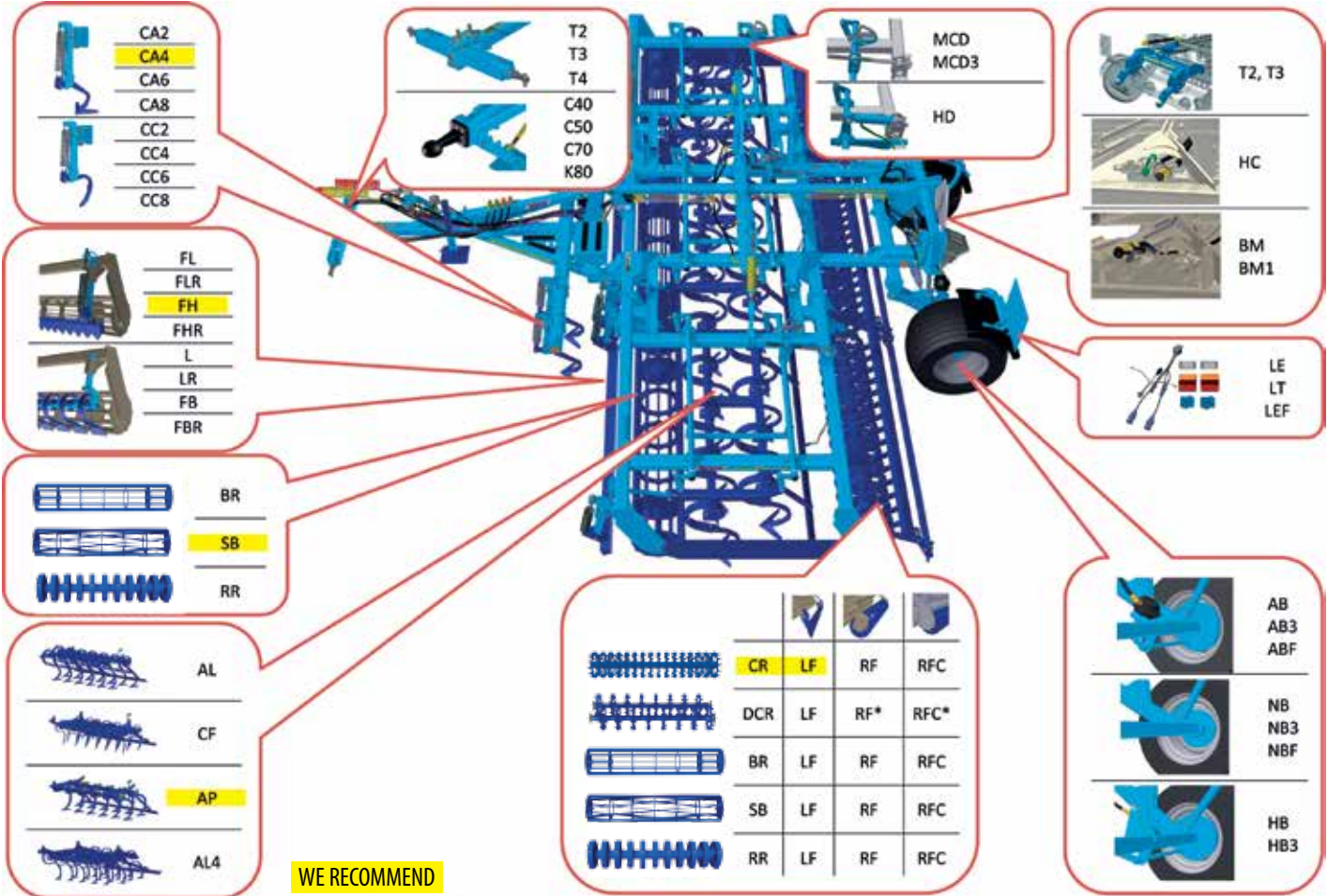

WE RECOMMEND

\*DCR/RF(RFC) | K250N | K300N | K400NS | K500NS | K600NS | K1250PS | K1570PS





**eXtra STEEL line**  
ultra high strength steel technology

**10–14 km/h**  
**6–8 mph**

Crumbling rollers are especially suitable for improvement of the soil processing with Kompaktomat. They are used mainly in heavy soils, in summer and autumn seasons. They effectively crumble clods.

Technical parameters	Units	DV 300 N	DV 400 NS	DV 450 NS	DV 500 NS	DV 600 NS	DV 700 NS	DV 800 NS	DV 1000 NS
Working width	mm / ft	3000 / 9.8	4000 / 13.1	4500 / 14.8	5000 / 16.4	6000 / 19.7	7000 / 23	8000 / 26.3	9850 / 32.3
Transport width	mm / ft	3000 / 9.8	3000 / 9.8	3000 / 9.8	3000 / 9.8	3000 / 9.8	3000 / 9.8	3000 / 9.8	3000 / 9.8
Transport height	mm / ft	1045 / 3.4	1650 / 5.4	1890 / 6.2	2130 / 6.9	2610 / 8.6	3090 / 10.1	3565 / 11.7	3755 / 12.3
Total machine length	mm / ft	1500 / 4.9	1500 / 4.9	1500 / 4.9	1500 / 4.9	1500 / 4.9	1500 / 4.9	1500 / 4.9	2200 / 7.2
Number of wheels	pcs	24	34	40	44	52	60	68	81
Working performance	ha/h (ac/h)	2.5–3.0 (6–7.5)	3.0–4.0 (7.5–10)	3.0–4.5 (7.5–11.1)	3.0–5.0 (7.5–12.4)	3.5–6.0 (8.7–14.8)	4.5–7.0 (11–17.3)	5.5–8.0 (14–19.8)	7.0–10.0 (17.3–24.7)
Towing vehicle	kW / HP	15 / 20	20 / 27	23 / 31	25 / 34	30 / 39	35 / 46	40 / 52	50 / 65
Machine weight	kg / lb.	560 / 1235	1055 / 2326	1135 / 2502	1255 / 2767	1400 / 3087	1600 / 3527	1760 / 3880	2550 / 5622

Více informací na [www.farmet.cz](http://www.farmet.cz)



1

1. Fine pre-sowing soil processing – crushing of clods by rolling.

- Additional crumbling crosskill rollers aggregated to the rear hitch TPH of the presowing combinator Kompaktomat are in widespread use for **more intensive processing of the soil**, especially heavy soil.
- During transportation the rollers are carried and therefore manoeuvrability of the machine is not reduced at all.
- The advantage of this machine is its **multipurposeness and adjustability** bringing **high variability of work**.



N

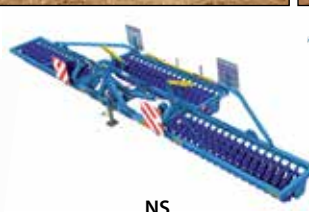

NS

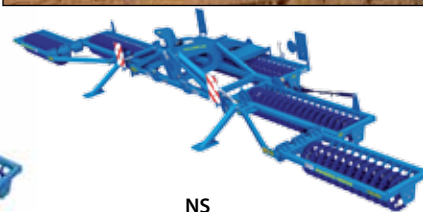

NS



# VERSO

cultivators

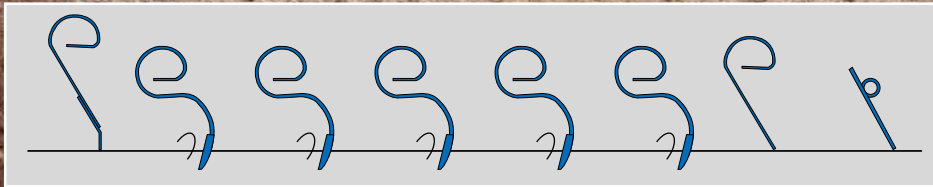

PRESOWING PREPARATION







Cultivator Verso is especially suitable for **pre-sowing preparation of the soil after ploughing or stubble-breaking**. It levels the soil surface and prepares the sowing bed.

It also ensures **excellent passability under heavier and wet conditions**. It is resistant to rolling up and congestion with a high levelling effect. It is also suitable for very early spring soil processing after winter or for autumn works. It ensures shallow cultivation with incorporation of plant residues and destruction of weeds. It is equipped with chisels with plates of cemented carbides.

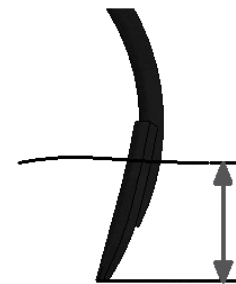

0–100 mm (0–4 in)

**8–15 km/h**  
**5–9 mph**

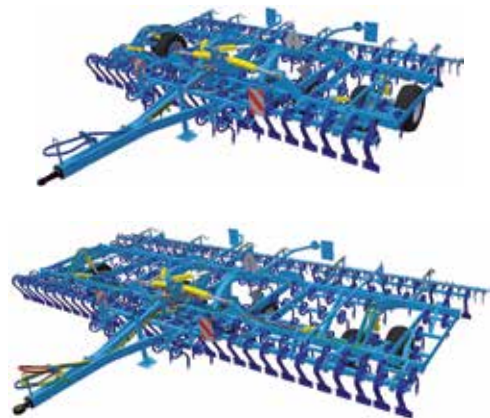

**eXtra STEEL line®**  
ultra high strength steel technology



# VERSO PS

- Cultivator Verso is especially suitable for **pre-sowing preparation of the soil after ploughing or stubble-breaking – levelling of the surface and preparation of the sowing bed.**
- Verso is a half-carried 5-row cultivator with **low traction resistance** and variable processing depth from 0 to 10 cm. Flexible ploughshares with chisels of the width of 37 mm ensure **intensive and fine soil processing.** The tines are flexibly fixed to the frame in the distance of 57 cm with **the possibility of deflection in case of an impact on an obstacle.**
- A great advantage of the cultivator is its **excellent passability and resistance to clogging.** When in operation, the cultivator is carried by integrated travel wheels that allow the operating staff to smoothly regulate the working depth according to the current soil conditions and thus prevent potential clogging of the machine, e.g. by lifting it up.

## High performance and quality of work

- High working **speed up to 15 km/h.**
- **Low traction resistance** and excellent mixing of the soil due to the optimized design of ploughshares and their distribution.
- **Flexible ploughshares with chisels** of the width of 37 mm ensure intensive and fine soil processing.
- The chisels are flexibly fixed to the frame with **the possibility of deflection in case of an impact on an obstacle.**
- Frame height of 43 cm, integrated travel axle with hydraulic adjustment of the working depth and flexi boards controlled from the tractor.



## Robust design

- The spacing of chisels is 75 mm. The curved shape of the shank has an excellent ability to maintain **the same working depth** according to the setting, even in the harshest conditions.
- The cultivator can simply be folded into the maximum transportation width of 3 metres and height of 4 metres, which meets the regulations for operation on the road network.





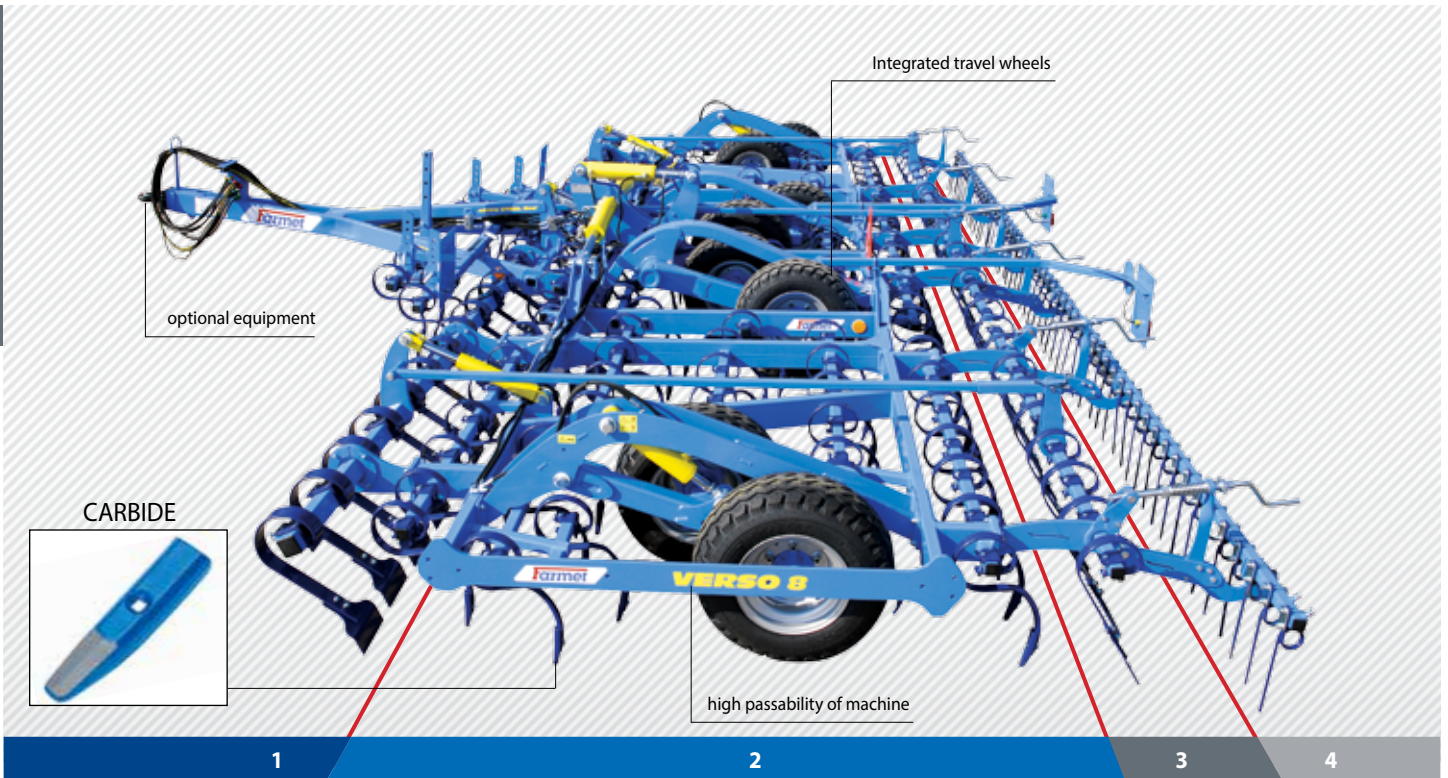

1. Hydraulically controlled front flexi-board leveller ensures spreading of large clods and basic surface levelling.
2. Flexible ploughshares with chisels of th width 37 mm in five rows ensure intensive and fine soil processing up to the depth of 10 cm.
3. Hydraulically controlled light rear flexi-board leveller levels unevenness of the soil.
4. The rear harrow smoothes the soil.



Technical parameters	Units	Verso 6 PS	Verso 7 PS	Verso 8 PS	Verso 9 PS
Working width	mm / ft	6000 / 19.7	7000 / 22.9	8000 / 26.3	9000 / 29.5
Transport width	mm / ft	3000 / 9.8	3000 / 9.8	3000 / 9.8	3000 / 9.8
Transport height	mm / ft	3160 / 10.4	3720 / 12.2	4000 / 13.1	4580 / 15
Total machine length	mm / ft	6800 / 22.3	6800 / 22.3	6800 / 22.3	6800 / 22.3
Working depth	mm / in	0-100 / 0-4	0-100 / 0-4	0-100 / 0-4	0-100 / 0-4
Number of ploughshares	pcs	77	91	101	115
Working performance	ha/h (ac/h)	8.0-10.0 (20-25)	9.0-11.0 (22-27)	10.0-12.0 (25-30)	11.0-13.0 (27-32)
Towing vehicle	kW / HP	130-195 / 180-270	150-225 / 205-308	160-240 / 220-330	180-270 / 245-368
Machine weight	kg / lb.	3570 / 7871	3920 / 8642	3960 / 8730	4350 / 9590

More info at [www.farmet.eu](http://www.farmet.eu)





# FALCON

modular sowing machines







Modular sowing machine Falcon is especially suitable for both minimizing and classic technologies. It is also suitable for sowing in all conditions and for all technologies – after ploughing, stubble-breaking, into mulch and without preparation. It enables sowing of two crops or variants, sowing with additional fertilization and use of STRIP-TILL technology of strip soil processing. Row spacing is user selectable. Perfectly prepares the sowing bed with optimum soil compaction.

**10–20 km/h**  
**6–12 mph**



PRO 3 m



PRO 4 m



PRO 6 m



PRO 8 m



SW



COMPACT

**eXtra STEEL line®**  
ultra high strength steel technology



# FALCON PRO

- Due its modularity, modular sowing machine Falcon is intended for all conditions and all technologies. Especially the mini-mizing technology uses **sowing into unprepared soil with the applied fertilizer**. At conventional technology with pre-sowing soil preparation, high working speed, **excellent stability and manoeuvrability of the machine** can be used.
- Falcon combines soil preparation, additional fertilization and sowing itself into one operation, **into one run**. The conception of the sowing machine is based on **optionality and combination of all working sections** and their interchangeability. Between the pre-processing and sowing sections there is the tyre-packer with integrated travel axle. The sowing bed before each drill coulters is perfectly recompactd by the flotation (low-pressure) tyres. The wheels are resistant against damage.
- Falcon is a very compact machine with a low weight and low traction resistance. **The management and control system** is, of course, a part of the machine.

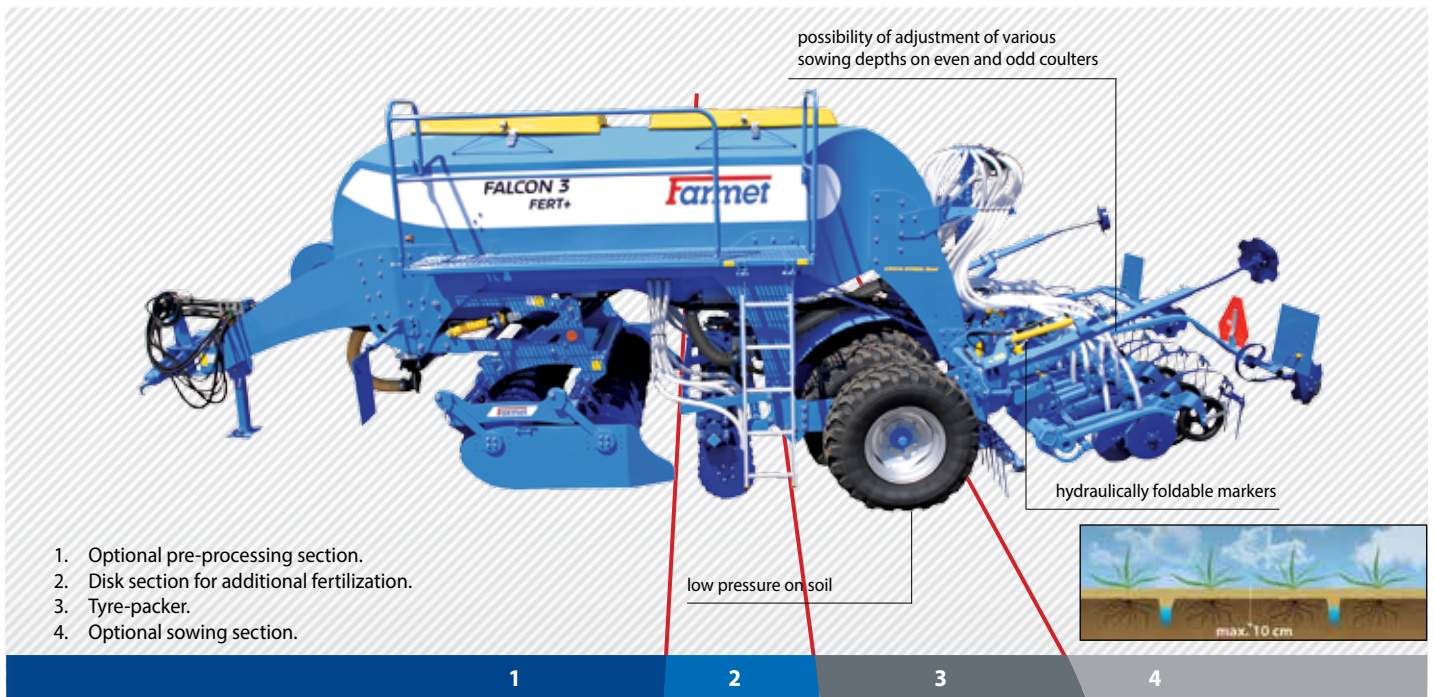

## High performance and quality of work

- High working **speed up to 20 km/h**.
- **Low traction resistance** due to a low weight and large wheels.
- **Shorter idle periods for filling of feeders** thanks to a large capacity.
- **Fast turning at headlands** due to a short compact design.
- **Precise dept guidance** with optimum soil compaction.
- **Perfect surface levelling and compaction** in front of the drill coulters.

## Robust design

- The flexible construction of the frame **excellently absorbs shocks and traces the terrain**.
- **Maintenance-free placement of all disks** ensuring operation of the machine without the need of additional lubrication.
- **Resistant and maintenance-free rubber mounting of the drill coulters** for adaptation to terrain with protection against overload.
- Due to minimum of adjusting and lubricating points the operation and subsequent maintenance are **very easy steps** that anybody can perform.





**MODULAR SYSTEM FALCON PRO**

0-10 cm

10-30 cm

10-20 cm

0-10 cm

0-10 cm

0-10 cm

0-10 cm

4000 l

6000 l - FERT+

**E**

**A**

**D**

**B**

**C**

**ME TOUCH 1200**  
ISO-BUS (12,1")

**ME TOUCH 800**  
ISO-BUS (8")

**ME BASIC TERMINAL**  
ISO-BUS (5,7")

**ME COMFORT TERMINAL**  
ISO-BUS (10,4")



Sowing of cereals into narrow lines with possibility of fertilization under the heel.



Sowing of rape with deep loosening and fertilizer application.



Precision sowing of corn and fertilizer application.





# FALCON PRO

## NEW OPTIONAL EQUIPMENT

E



MICRO DRILL



SOWING



A

## CLOSE DRILL TECHNOLOGY



### Close drill technology

- Areal soil cultivation into the seedbed depth.
- Option of fertilisation under seeds.
- Sowing all common crops.



Technical parameters	Units	Falcon 3 PRO	Falcon 4 PRO	Falcon 4 FIX PRO	Falcon 6 PRO	Falcon 8 PRO
Working width	mm / ft	3000 / 9.8	4000 / 13.1	4000 / 13.1	6000 / 19.7	8000 / 26.3
Transport width	mm / ft	3000 / 9.8	3000 / 9.8	4000 / 9.8	3000 / 9.8	3000 / 9.8
Transport height	mm / ft	2700 / 8.9	3300 / 10.8	3300 / 10.8	3300 / 10.8	4000 / 13.1
Hopper vol. without additional fertilization	l	4000	4000	4000	4000	4000
Hopper vol. with additional fertilization	l	6000	6000	6000	6000	6000
Working performance	ha/h (ac/h)	3.0–4.5 (7.5–11.1)	4.0–6.0 (9.8–14.8)	4.0–6.0 (9.8–14.8)	6.0–9.0 (14.8–22.2)	8.0–12.0 (20–30)
Towing vehicle	kW / HP	92 / 125	117 / 160	117 / 160	161 / 220	205 / 280
Machine weight	kg / lb.	4830–5840 / 10648–12875	5340–7580 / 11773–16711	5040–7280 / 11111–16050	6800–8920 / 14991–19665	8440–10240 / 18607–22575

More info at [www.farmet.eu](http://www.farmet.eu)





# FALCON PRO STRIP

B

## STRIP TILL SOWING TECHNOLOGY

The best solution for rapeseed.



## STRIP TILL & SOWING & FERTILIZATION

### STRIP TILL sowing technology

- Deep cultivation, additional fertilization (optional) and sowing at one line.
- Strip (partial) processing of the soil to the depth.
- Sowing of winter oilseed rape and special crops.

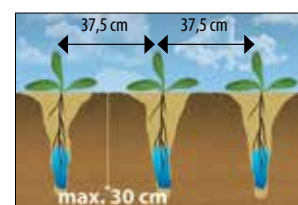
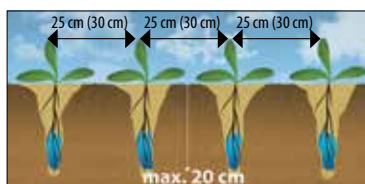



C

## SOWING TECHNOLOGY OF WIDE ROW CROPS & FERTILIZATION



### Sowing technology of wide row crops

- Sowing at precisely defined distance (e.g., maize, sunflower).
- Spacing of 75 cm.
- Possibility of additional fertilization with disk applicators from both sides of the row.

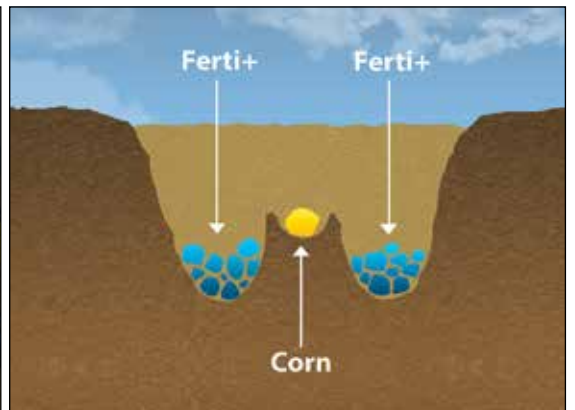



# FALCON PRO TANDEM

D

SHARE SOWING MACHINES



8–15 km/h  
5–9 mph

**eXtra STEEL line**  
ultra high strength steel technology

The Falcon Pro Tandem seed drill is a modular version of the Falcon Pro seed drill, providing strip seeding using special shares with tandem-configured outputs for seeding and parallel placement of the fertilizer into the root zone. This seeding method is suitable for sowing into mulch, as well as standard cultivated soil. The front and rear tyre rollers provide a high precision depth guidance with accurate working depth adjustment of the seeding discs. A highly durable and robust frame means the machine is suitable for stony soils.





- The Falcon Pro Tandem seed drill uses the modular foundation of Falcon Pro, equipped with the front seeding section and tyre packer with three rows of special seeding shares. The seeding shares are followed by a leveller system, excellent for effective levelling of the surface and even distribution of crop residue.
- The rear roller equipped with large low-pressure tyres provides very low ground pressure on the soil, even when the seed and fertilizer hoppers are completely full. The robust tyres have high resistance to penetration and allow for transportation of the machine at high speeds, even for greater distances or on poor quality roads
- The special seeding shares with tandem-configured outputs for seeding and parallel placement of fertilizer into the root zone provide quality seeding, even under the conditions of a high quantity of crop residue in mulch seeding technologies. The precise depth guidance by tyre rollers helps achieve seeding depth precision comparable with disc seed drills.
- The robust frame of the machine makes it also suitable for rocky soils.

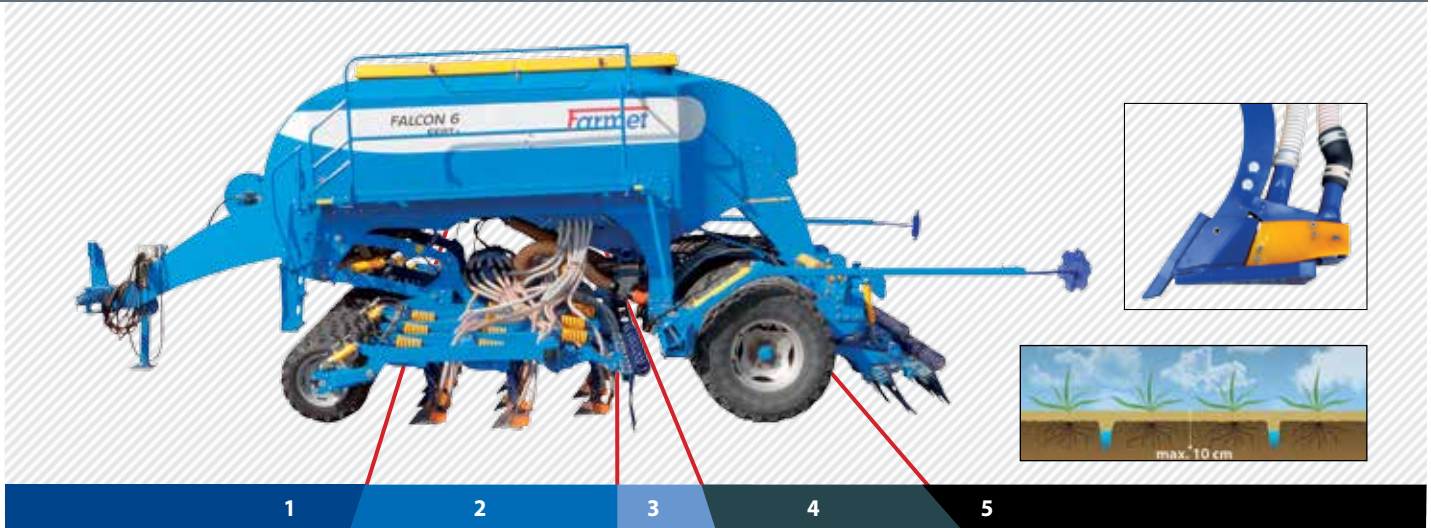

### High performance and quality of work

- Reduced downtime for tank filling thanks to the large capacity hopper.
- Fast headland turns at the due to the short compact frame.
- Low pulling resistance with the reduced weight and share technology.
- Excellent depth guidance and accurate seed placement with the front and rear roller system. Perfect levelling, compaction and soil cultivation in a single pass.

### Robust design

- **High-strength materials** are used on key elements of the frame for durability
- Durable and **maintenance-free bearing** of all working parts.
- Large transport low-pressure radial tyres resistant to penetration and wear.

1. Front rubber-tyred roller.
2. Chisel section for additional fertilization.
3. Harrow for levelling the surface.
4. Rear double tyre-packer.
5. Harrow for levelling the surface.

Technical parameters	Units	Tandem 6 PRO Tandem
Working width	mm / ft	6000 / 19.7
Transport width	mm / ft	3000 / 9.8
Transport height	mm / ft	3250 / 10.7
Total machine length	mm / ft	7800 / 25.6
Working depth	mm / in	0–100 / 0–4
Number of drill coulters	pcs	24
Working performance	ha/h (ac/h)	4.0–6.0 (9.8–14.8)
Towing vehicle	kW / HP	147 / 200
Machine weight	kg / lb.	6500–7500 / 14300–16600

More info at [www.farmet.eu](http://www.farmet.eu)





# FALCON SW



10–20 km/h  
6–12 mph

The modular Falcon SW seed drill is a simplified, balanced and universal version of the Falcon seed drill. It is designed for sowing all common crops in various crop establishment technologies with the option of selectin various seeding sections.

Technical parameters	Units	Falcon SW
Transport width	mm / ft	3000 / 9.8
Hopper vol. without additional fertilization	l	4000
Hopper vol. with additional fertilization	l	6000

More info at [www.farmet.eu](http://www.farmet.eu)



Wide seeding bar for sowing close-drilled crops.



Mounted seed drill for sowing wide-row crops.



Mounted cultivator for strip-till soil cultivation.



**MODULAR SYSTEM FALCON SW**

4000 I

6000 I - FERT+

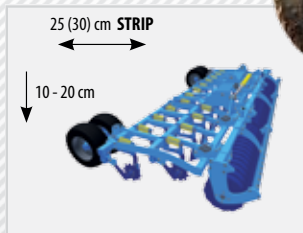
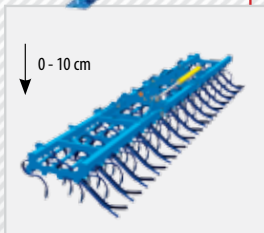
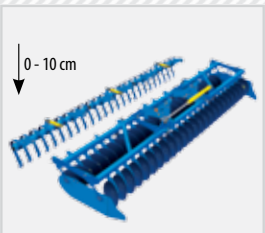

**extra STEEL line**  
ultra high strength steel technology



**METOUCH 1200**  
ISO-BUS (12,1")

**METOUCH 800**  
ISO-BUS (8")

**ME BASIC  
TERMINAL**  
ISO-BUS (5,7")

**ME COMFORT  
TERMINAL**  
ISO-BUS (10,4")

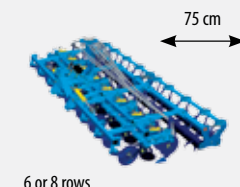
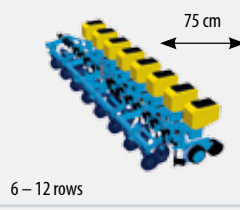
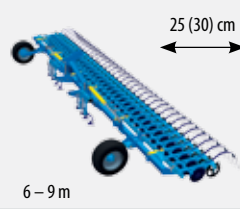
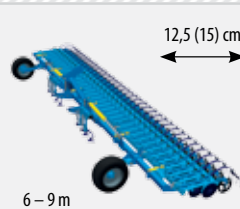



# FALCON SW

## CLOSE DRILL TECHNOLOGY



## STRIP TILL SOWING TECHNOLOGY



## SOWING TECHNOLOGY OF WIDE ROW CROPS & FERTILIZATION



## FALCON SW + IMPACT





10–20 km/h  
6–12 mph

## MODULAR SYSTEM

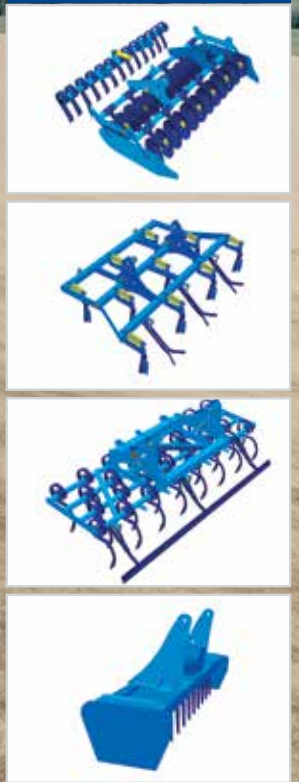

Falcon Compact is a compact, simplified version of the Falcon seed drills for establishing growth after tillage, deep cultivation as well as stubble cultivation with fixed equipment. Falcon Compact is designed for farmers who prefer narrow wheels of the packer, a large hopper capacity and the inter-row seed spacing of 15cm.

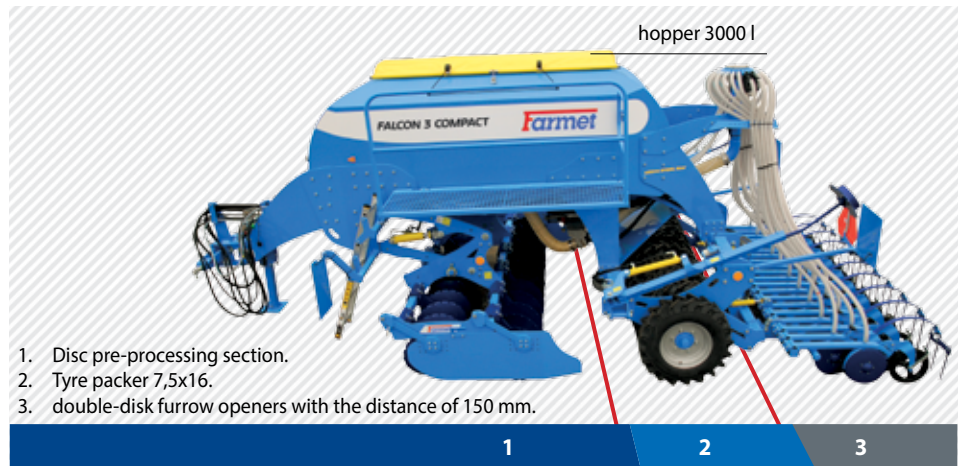

1. Disc pre-processing section.
2. Tyre packer 7,5x16.
3. double-disk furrow openers with the distance of 150 mm.

hopper 3000 l

Technical parameters	Units	Falcon 3 COMPACT	Falcon 4 COMPACT
Working width	mm / ft	3000 / 9.8	4000 / 13.1
Transport width	mm / ft	3000 / 9.8	4000 / 13.1
Transport height	mm / ft	2800 / 9.1	2800 / 9.1
Hopper vol. without additional fertilization	l	3000	3000
Working performance	ha/h (ac/h)	3.0–4.5 (7.5–11.1)	4.0–6.0 (9.8–14.8)
Towing vehicle	kW / HP	88 / 120	103 / 140
Machine weight	kg / lb.	3800 / 8380	4400 / 9700

More info at [www.farmet.eu](http://www.farmet.eu)



ME DRILL  
Control  
(5,7")



ME TOUCH 1200  
ISO-BUS (12,1")



ME TOUCH 800  
ISO-BUS (8")



ME BASIC  
TERMINAL  
ISO-BUS (5,7")



ME COMFORT  
TERMINAL  
ISO-BUS (10,4")





# IMPACT

precise seed drills



8–15 km/h  
5–9 mph

Impact is a modern precision seed drill with an advanced pneumatic seeding system and top spec electronic seeding control system providing a high precision seeding with high working speeds. Impact is also equipped with a system of double-sided disk units, configured in tandem for fertilizer application. This not only ensures precise seed placement at the required depth, but also strip-till soil processing and seedbed preparation.

- Impact is designed for precise seeding of wide-row crops such as maize, sunflower, and rapeseed with the option of additional fertilization using granulated fertilizers. Impact has a heavy duty frame to ensure accurate placement of fertilizer and seeds at the required depth, with ability to work in heavier soil conditions.
- The system of tandem-configured disk fertilization units not only provides precise double-sided placement of fertilizer in the root zone, but also strip-till pre-processing for subsequent precise placement of seeds into a prepared seedbed.
- The design of the Impact seed drill allows high working speeds from 10 to 15 km/h depending on the soil conditions.
- The seeding units are equipped with a highly advanced seeding control system. Specially placed sensors scan each individual seed and assess accurately for gaps or doubles. All the working and output information is displayed on the ISO-bus terminal in the tractor cab. All of the machine functions can be constantly checked by the operator and on-the-move modifications, adjustments and speed can be made according to the soil conditions.

## ELECTRONIC SEEDING CONTROL SYSTEM

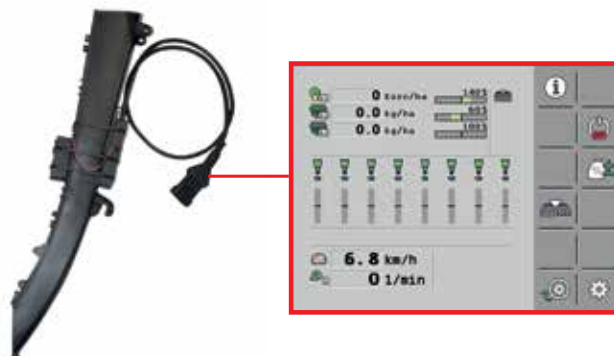

ME TOUCH 1200  
ISO-BUS (12,1")



ME TOUCH 800  
ISO-BUS (8")



ME BASIC  
TERMINAL  
ISO-BUS (5,7")



ME COMFORT  
TERMINAL  
ISO-BUS (10,4")





### High performance and quality of work

- **High working speed** of up to 15 km/h, high seeding rate reliability.
- **Highly advanced electronic control system** for each seed placed.
- Electronic control of all functions of the machine during work – ISO bus system.
- Double-sided fertilization with tandem-configured disk units.
- **Strip-till soil pre-processing** and seedbed preparation.

### Robust design

- Hydraulic folding into the transportation position.
- **Durable and maintenance-free bearing of all disks.**
- **Durable and maintenance-free rubber bearing** of fertilization units with overload protection.
- **Highly durable seeding units** with flexible pressure adjustment.

Technical parameters	Units	Impact 6	Impact 8
Working width	mm / ft	4500 / 14.8	6000 / 19.7
Number of seeding units	pcs	6	8
Transport width	mm / ft	3000 / 9.8	3000 / 9.8
Transport height	mm / ft	2400 / 7.9	2400 / 7.9
Total machine length	mm / ft	2350 / 7.7	2350 / 7.7
Number of fertilising disks	pcs	12	16
Working performance	ha/h (ac/h)	4.5–6.0 (11–15)	6.0–9.0 (15–22)
Towing vehicle	kW / HP	75 / 100	90 / 125
Machine weight	kg / lb.	2700 / 5950	3200 / 7056

More info at [www.farmet.eu](http://www.farmet.eu)



1. Double-sided additional fertilisation using disc units.
2. Precise seeding units.

## SOWING TECHNOLOGY OF WIDE ROW CROPS & FERTILIZATION

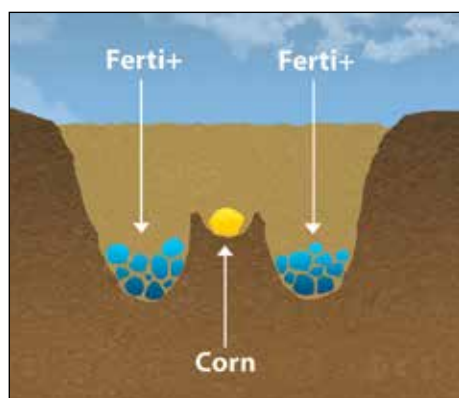

### FALCON SW + IMPACT



### MONSUN MF + IMPACT





# MONSUN

Pneumatic sowing machines



ME

Pneumatic sowing machine Monsun is especially suitable for row sowing of wide range of crops (cereals, legumes, oilseeds, grasses). It is characterized by precise dosage of seeds in the range from 2 to 380 kg. It is intended for small and medium areas. It can be aggregated separately or in combination with the machines for soil preparation. Aggregation is possible into a three-point tractor hitch. When in the working position, as a half-carried machine it rests on its own travel wheels.

8–15 km/h  
5–9 mph



MC



- Sowing after ploughing in the processed soil.
- Possibility of aggregation with the machine for soil preparation.
- Light carried design.
- Large seed hopper.
- Very low traction resistance.

### Smartly designed machine

- Monsun MA is designed for **independent sowing** or for **combination with the machines for soil processing** in small and medium areas.
- **Aggregation with rotary harrows** (Monsun MB, MC)
- Monsun MD is **characterized by a low weight and large hopper volume**.
- **Hydraulic folding to 3 metres of the transport width** (Monsun ME).
- **Light carried design with large hopper** (Monsun MF).

### Easy operation

- Easy adjustment of the sowing depth, pressure of coulters and sowing dosage.
- Minimum of adjustment points.
- Minimum of lubrication points.
- Inspection of sowing functions of well-arranged electronic system.



1. Disk drill coulters.
2. Rear harrow for levelling the surface.

Technical parameters	Units	Monsun MA 300	Monsun MA 400	Monsun MA 450	Monsun MC / MCM 300	Monsun MC / MCM 400	Monsun MC / MCM 450
Working width	mm / ft	3000 / 9.8	4000 / 13.1	4500 / 14.8	3000 / 9.8	4000 / 13	4500 / 14.8
Hopper volume	l / cu ft	1150 / 40	1150 / 40	1150 / 40	1150 / 1300 (40/46)	1150 / 1300 (40/46)	1150 / 1300 (40/46)
Number / width of rows	pcs	24 / 32	24 / 32 / 40	32 / 36 / 40	24 / 32	32 / 40	36 / 40
Working depth	ha/h (ac/h)	1.5–3.6 (3.7–8.9)	2.0–4.8 (5–11.9)	2.3–5.5 (5.7–13.6)	1.5–3.6 (3.7–8.9)	2.0–4.8 (5–11.9)	2.3–5.5 (5.7–13.6)
Towing vehicle	kW / HP	44 / 60	59 / 80	66 / 90	88 / 120	118 / 160	140 / 180
Machine weight	kg / lb.	600 / 1323	660 / 730 (1455–1609)	720 / 800 (1587–1764)	2400 / 5304	2850 / 6283	3100 / 6834

Technical parameters	Units	Monsun ME 500	Monsun ME 600	Monsun ME 660	Monsun ME 800	Monsun MF 300	Monsun MF 400
Working width	mm / ft	5000 / 16.4	6000 / 19.7	6600 / 21.7	8000 / 26.3	3000 / 9.8	4000 / 13
Hopper volume	l / cu ft	2000 / 70.6	2000 / 70.6	2000 / 70.6	2000 / 70.6	1100 / 38.9	1100 / 38.9
Number / width of rows	pcs	40 / 48	48 / 64	48 / 64	64	24 / 32	32 / 40
Working depth	ha/h (ac/h)	2.5–6.1 (6.2–15)	3.0–7.2 (7.5–17.8)	3.0–8.1 (7.5–20)	4.0–9.6 (10–23.7)	1.5–3.6 (3.7–8.9)	2.0–4.8 (5–11.9)
Towing vehicle	kW / HP	110 / 150	118 / 160	118 / 160	118 / 160	89 / 110	110 / 150
Machine weight	kg / lb.	2300 / 5070	2500 / 5512	2750 / 6063	3000 / 6614	395 / 430 (871/948)	395 / 500 (871/1102)

More info at [www.farmet.eu](http://www.farmet.eu)





# CAMBRIDGE

rollers



Cambridge rollers are especially suitable for **additional pre-sowing soil processing, restoration of soil capillarity, crumbling of clods and surface levelling**. They are also suitable for the soil processing after sowing – more uniform seed emergence and acceleration of vegetation.

**8–15 km/h**  
**5–9 mph**



Ø 500 mm (20 in)



1

1. Fine after-sowing soil processing – crushing of clods by rolling.

**extra STEEL line**  
ultra high strength steel technology

- Cambridge rollers are designed for **additional pre-sowing soil processing**, especially in heavy dry conditions.
- Cambridge rollers are used for **levelling of the surface, crumbling of clods and restoration of soil capillarity**. The machine can also be used after sowing. Working operation performed in this way increases uniformity of seed emergence and subsequently acceleration of vegetation.



Technical parameters	Units	Cambridge CV 6	Cambridge CV 9
Working width	mm / ft	6000 / 19.7	9000 / 29.5
Transport width	mm / ft	2400 / 7.9	2400 / 7.9
Transport height	mm / ft	1600 / 4.5	1600 / 4.5
Total machine length	mm / ft	4100 / 13.5	6800 / 22.3
Number of segments (smooth/geared)	pcs	58 / 55	88 / 83
Working performance	ha/h (ac/h)	6.0 (15)	9.0 (22)
Towing vehicle	kW / HP	75 / 100	90 / 125
Machine weight	kg / lb.	2700 / 5960	3600 / 7940

More info at [www.farmet.eu](http://www.farmet.eu)



# KULTIS

cultivators



Cultivator and fertilizer applicator Kultis is especially suitable for cultivation and aeration of the spaces between the vegetation rows, application of liquid fertilizer into the plant root zone, destruction of grown weeds between the plant rows and disruption of the soil crust. Cultivator Kultis enables adjustment of the precise dose of 60–160 l/ha and possibility of application up to the height of the vegetation of 40–50 cm.

8–12 km/h  
5–7 mph

### Advantages of use of Kultis cultivator

- Using the cultivator with additional fertilization with regard to the supply of soil nutrients allows **decreasing the doses of phosphorus and nitrogen by 30 to 50 %**.
- Kultis cultivator **eliminates grown weeds** between the maize rows.
- Using the cultivator **the soil is cultivated and aerated**.
- The working units of the cultivator **reliably destroy** any potential **soil crust** that some soils are prone to.

### Smartly designed machine

- The disk coulters on the sides of the ploughshare prevent plant damage and promote better soil separation and aeration in heavy soils without damaging the maize rows.
- Smooth transition from the inter-row distance of 70 cm to 75 cm.
- Land surface tracing.

Technical parameters	Units	Kultis 6	Kultis 8
Transport width	mm / ft	3000 / 9.8	3000 / 9.8
Number / width of rows	pcs	6	8
Hopper volume	l / cu ft	1350 / 48	1350 / 48
Towing vehicle	kW / HP	55 / 75	75 / 100

More info at [www.farmet.eu](http://www.farmet.eu)



arrow shares

1. Ploughshares for soil cultivation and stubble-breaking.



# ELEFANT

sewage containers



Sewage container Elefant is designed as an intermediate liquid manure container enabling that **the applicator do not have to wait for a tank**. When properly placed on the land edge, **no compaction of the soil profile by the tank occurs**. Prior to transport from one locality to another, the liquid manure must be emptied from container.



1

2

1. Filling, emptying, stirring.
2. Storage.

- Mobile container Elefant for liquid organic manure complements the export line and its applications which substantially increases productivity and **simultaneously increases effectiveness of the process as a whole**.
- The filling and draining openings are located on opposite sides of the tank, so both processes can **take place independently**. The location of the filling and draining opening together with the slant bottom ensure **good circulation of liquid manure** and the solid part is not being deposited.

Technical parameters	Units	Elefant ZK 35	Elefant ZK 50
Width	mm / ft	2500 / 8.2	2550 / 8.4
Height	mm / ft	3200 / 10.5	3350 / 11
Length	mm / ft	9500 / 31.2	10900 / 35.8
Volume	m <sup>3</sup>	35	50
Towing vehicle	kW / HP	50-75 / 68-100	50-75 / 68-100
Machine weight	kg / lb	5100 / 11244	7500 / 16535

More info at [www.farnet.eu](http://www.farnet.eu)

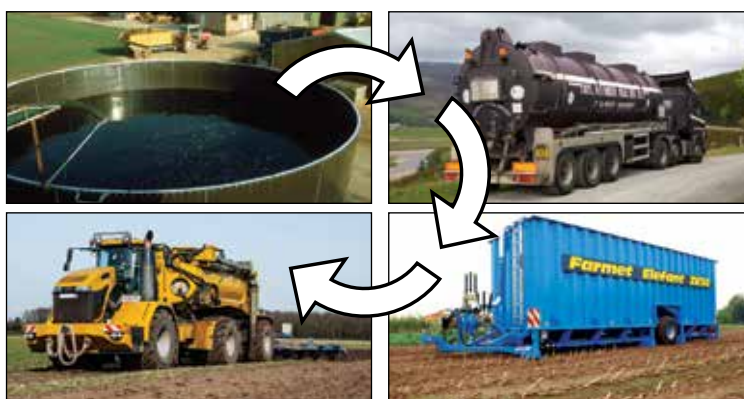



# OIL & FEED TECH



**HEXANE FREE  
TECHNOLOGIES®**





# OIL & FEED TECH



complete pressing technology for extracting vegetable oils  
kompletní lisovací technologie pro získávání rostlinných olejů  
komplette Presstechnologie für die Gewinnung von Pflanzenölen  
полная технология прессования для производства растительных масел  
комплектна технологія пресування для одержання рослинних олій  
kompletna technologia wytłaczania pozwalająca na otrzymanie olejów roślinnych  
technologie de pressage complète pour obtenir les huiles végétales  
tecnologia completa de prensado para obtener aceites vegetales  
tehnologie completă de presare pentru obținerea de uleiuri vegetale  
комплектна пресовъчна технология за извличане на растителни масла  
komplett növényi olaj sajtoló technológiák  
presavimo tehnologinè įranga augaliniam aliejui išgauti  
kompleksa presēšanas tehnoloģija augu eļļu iegūšanai  
täistehnoloogia õliseemnete pressimiseks





# THINK GLOBALLY ACT LOCALLY



## HEXANE FREE TECHNOLOGIES®

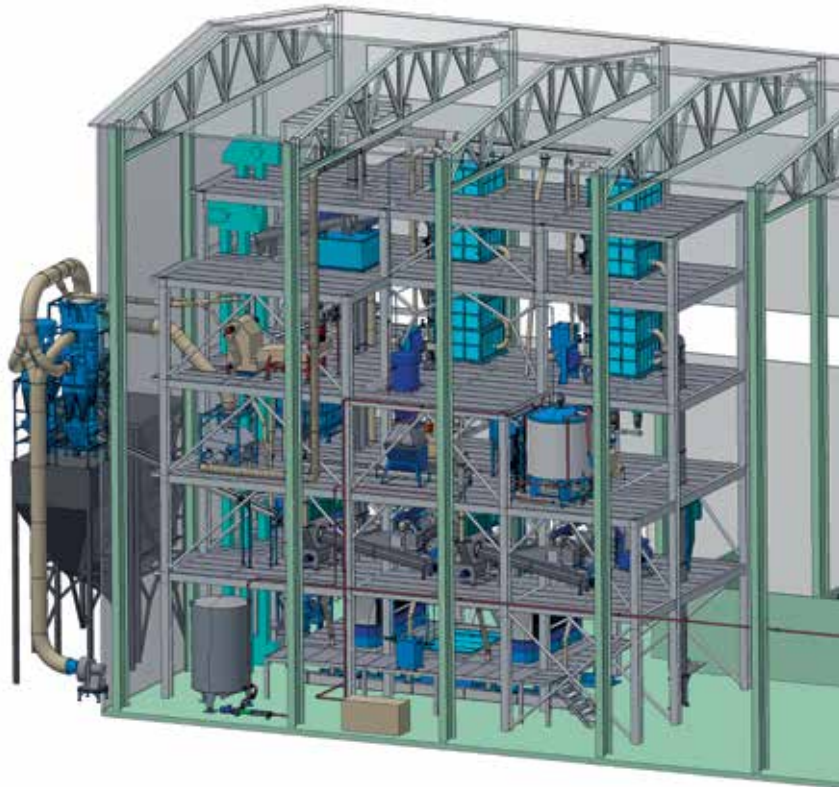

complete technology for processing vegetable oils  
 kompletní technologie pro zpracování rostlinných olejů  
 komplette Technologie zur Verarbeitung von Pflanzenölen  
 полная технология для переработки растительных масел  
 kompletna tehnologija dla pererobki roslinnych olij  
 kompletna technologia pozwalająca na przygotowywanie olejów roślinnych  
 technologie complète pour traiter les huiles végétales  
 tecnología completa de procesamiento de aceites vegetales  
 tehnologie completă pentru prelucrarea uleiurilor vegetale  
 комплектна технология за преработка на растителни масла  
 komplett növényi olaj feldolgozó technológiák  
 technolinė įranga augalinio aliejaus perdirbimui  
 kompleksa tehnoloģija augu eļļu pārstrādei  
 täistehnoloogia taimeõli töötlemiseks







extrusion lines for the preparation of fodder  
 extruzní linky pro přípravu krmiv  
 Extrusionslinien für die Vorbereitung von Futtermitteln  
 линии екструзии для производства кормов  
 екструзійні лінії для підготовки кормів  
 linia ekstruzji do przygotowywania pasz  
 lignes d'extrusion pour la production des fourrages  
 plantas de extrusión para la preparación de piensos  
 linii de extrudare pentru prepararea furajelor  
 екструзни линии за приготвяне на фураж  
 takarmány előkészítő extrudáló sorok  
 ekstrudavimo linijos pašarų ruošimui  
 ekstrūzijas linijas lopbarības sagatavošanai  
 ekstruderliinid loomasööda tootmiseks



**HEXANE FREE**  
TECHNOLOGIES®











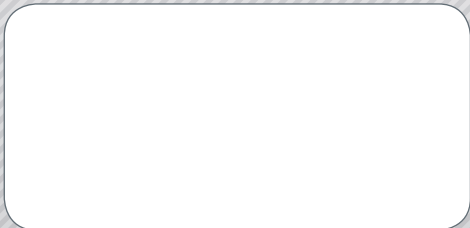

[www.farmet.eu](http://www.farmet.eu)

*Business representative of Farmet a.s.*



Farmet a. s.  
Jiřinková 276  
552 03 Česká Skalice  
 Czech Republic

**AGRICULTURAL MACHINERY**

Tel.: +420 491 450 122  
Fax: +420 491 450 136  
E-mail: [dzt@farmet.cz](mailto:dzt@farmet.cz)

**OIL & FEED TECH**

Tel.: +420 491 450 116  
Fax: +420 491 450 129  
E-mail: [oft@farmet.cz](mailto:oft@farmet.cz)

