

Your idea - Our drive.

Custom engineered gear technology & drive solutions at their best.

Franz Morat Group

 FMORAT CO

 FramoMorat



Combining compactness & precision.

The new low-backlash planetary gearbox series.

The new planetary gearbox series from Framo Morat includes the high-end gearbox lines GSD (flange gear), GSA, GSB, GSF (inline) and GSBL (angle gear) as well as the high-end economy GSN and GFE lines. Particularly suitable applications for the new range are those which place the highest demands on positioning accuracy, operating noises, running smoothness, bending rigidity and transmitted torque. The planetary gears are designed to meet the highest production requirements — all lines are equipped with precision ground helical gearing, single-piece planetary carriers and full needle bearings.

The GSA, GSB, GSF, GSD and GSBL high-end gearbox lines are constructed in a space-optimized, two-stage design. Due to the lower torque values, the input stage is dimensionally smaller than the output stage. The high-end economy lines GSN & GFE combine high performance with economic efficiency. They have been designed to reach high torques that beat the competition for units of the same size. In all lines, an additional shaft sealing ring ensures maximum dust and splash water protection in accordance with protection class IP65.



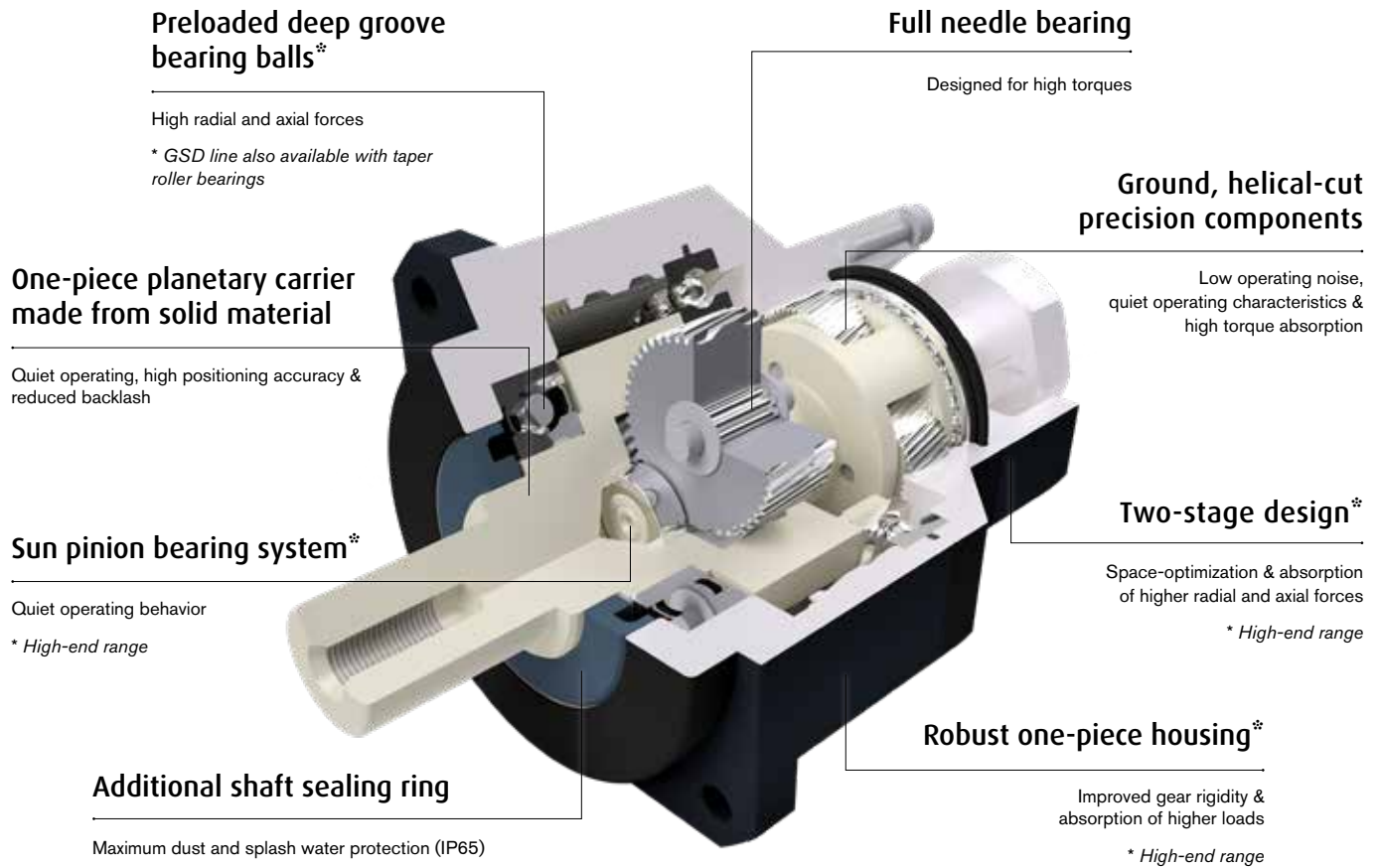

NEW: High-end range (GSA / GSB / GSF / GSD / GSBL)



- + High torsion levels through one part housing, helical gearing and full needle bearings
- + Suitable for highest demands on positioning accuracy & transmitted torque
- + Flange (GSD), inline (GSA, GSB, GSF) & angle (GSBL) versions
- + Space-optimized two-stage design
- + Backlash level up to 1 arcmin

NEW: High-end economy range (GSN / GFE)



- + Combining high performance & economic efficiency through helical gearing and full needle bearings
- + Suitable for highest demands on operating noises & running smoothness
- + Nominal output torques up to 1,562 Nm
- + Maximum dust and splash water protection (IP65)

Always on the move.

Stay one turn ahead with drive solutions from Franz Morat Group.

No matter what sector you work in or wherever you go in your freetime, you are very likely to find drives and components from Franz Morat Group closer to home than you might expect – our products are used in a vast range of applications...

If you need a reliable, experienced partner to help you realize your drive technology project, talk to us! We can supply individual components, assemblies or completely custom engineered drive units - in metal, plastic or a combination of the two materials! Let us inspire you: find out how to get that decisive inch of advantage over your competitors, using drive solutions supplied by the Franz Morat Group.

You benefit from:

- More than 100 years of expertise in designing & developing custom drive components & complete systems
- A commercially solid, family-owned company, with a flexible organization and the ability to react rapidly to customer requirements and changing circumstances
- Project specific choice of materials according to your requirements (metals, thermoplastics or combinations of both)
- Individual configuration for the material determination regarding quality, reliability, weight & running noise
- All process steps from a single source

Application examples



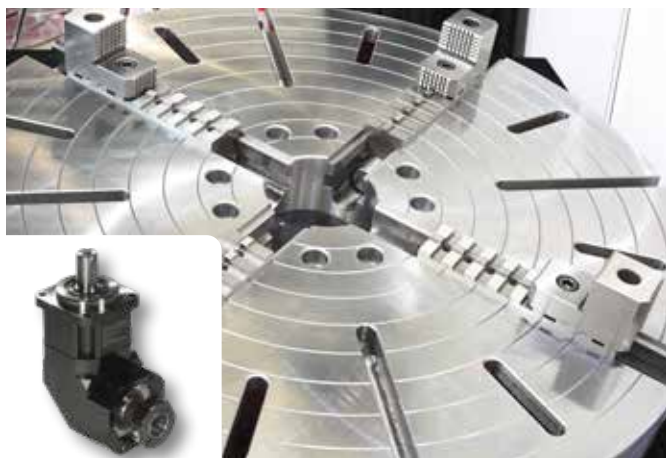

The best of both worlds.

Gear technology and drive solutions of both metals & plastics.



Combining local expertise & global presence.

Since the founding of Franz Morat GmbH in 1912, gear and drive engineering has been in a continuous state of development at the company's headquarters in Eisenbach, Black Forest. Today, the Franz Morat Group is a globally operating manufacturer of high-quality drive solutions for many industries and applications. The company counts over 650 employees and runs subsidiaries in the United States, Turkey, Poland and Mexico.



Uniting metals & plastics.

Our core competencies lie in the production of high-precision gears, rotor shafts and worm gear sets made from various metals as well as technically advanced injection-molded parts from thermoplastics. This results in solutions that incorporate the technical advantages of both material groups depending on the required specifications. You benefit from over 100 years of expertise and an experienced partner who offers all process steps from a single source.



Metal machining:

Turning, Milling, Gear Hobbing, Gear Shaping, Broaching, Hardening, Cylindrical Grinding, Honing, Profile & Hob Grinding



Plastic injection molding:

Mold Design & Tool Making, Over 70 injection molding machines, All technical thermoplastics (incl. PEEK™), Subsequent processing



Pioneering research & development.

In developing custom engineered drive solutions, Framo Morat and F. Morat cooperate closely under the umbrella of the Franz Morat Group. Our many years of experience make us your ideal partner, from development and design engineering to prototyping and testing all the way to series production and assembly. Numerous highly respected companies from a wide variety of industries rely on our development services and the resulting drive solutions.



Drive technology:

Specification, Development & Design, Prototyping, Testing & Quality Control, Serial Production, Assembly & Use



Franz Morat Holding GmbH & Co. KG

Franz-Morat-Straße 6
79871 Eisenbach
Phone +49 (0) 7657 88-0
Fax +49 (0) 7657 88-333
E-Mail info@franz-morat.com
www.franz-morat.com

Franz Morat Group

 F. MORAT CO

 Framo Morat