

| TECHNICAL SPECIFICATIONS  |                         |  |
|---------------------------|-------------------------|--|
| <b>EQUIPMENT TYPE</b>     |                         | Vertical Chiller   |
| <b>TEMPERATURE RANGE</b>  |                         | AMBIENT +16 °C / +25 °C<br>INNER* 0 °C / 8 °C<br>32 °F / 46,4 °F |
| <b>GROSS   NET VOLUME</b> |                         | 162 L (5,7 ft <sup>3</sup> )<br>115 L (4,1 ft <sup>3</sup> )     |
| EXTERNAL DIMENSIONS       |                         |  |
| <b>HEIGHT</b>             | 1800 mm                 |  |
| <b>DEPTH</b>              | 550 mm                  |  |
| <b>WIDTH</b>              | 500 mm                  |  |
| INTERNAL DIMENSIONS       |                         |  |
| <b>HEIGHT</b>             | 905 mm                  |  |
| <b>DEPTH</b>              | 410 mm                  |  |
| <b>WIDTH</b>              | 420 mm                  |  |
| INFO                      |                         |  |
| <b>LID/DOOR TYPE</b>      | No                      |  |
| <b>TOTAL DISPLAY AREA</b> | 0,38 m <sup>2</sup>     |  |
| <b>INTERNAL COATING</b>   | Pre Painted Metal Sheet |  |
| <b>CLIMATE CLASS</b>      | 3M1                     |  |
| <b>FREEZING CAPACITY</b>  | N.A.                    |  |

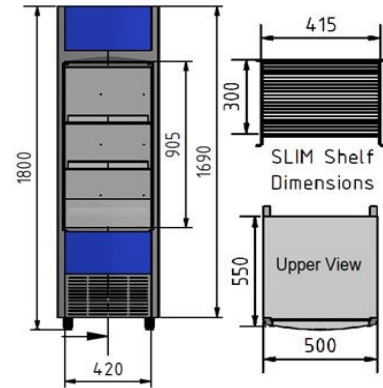

| ENERGETIC FEATURES         |                 |
|----------------------------|-----------------|
| <b>VOLTAGE / FREQUENCY</b> | 220-240V / 50Hz |
| <b>NOMINAL CURRENT</b>     | 5,26 A          |
| <b>POWER</b>               | 1071 W          |
| <b>CONSUMPTION</b>         | 16,5 kWh/24hr   |
| <b>ENERGY EFFICIENCY</b>   | N.A.            |
| <b>NOISE LEVEL</b>         | <55 dB          |
| ACCESSORIES                |                 |
| <b>BASKETS</b>             | 0               |
| <b>DIVIDER</b>             | 0               |
| <b>SHELVES</b>             | 3               |
| <b>WATER DRAIN</b>         | Yes             |
| <b>THERMOMETER</b>         | Yes-digital     |
| <b>LOCK</b>                | No              |

| COMPONENTS         |                 |
|--------------------|-----------------|
| <b>COMPRESSOR</b>  | Embraco         |
| <b>CONDENSER</b>   | Ventilated      |
| <b>THERMOSTAT</b>  | Carel - Digital |
| <b>REFRIGERANT</b> | R290            |
| <b>EVAPORATOR</b>  | Ventilated      |
| <b>LIGHT</b>       | LED             |

| PACKING LIST                 |       |
|------------------------------|-------|
| PACKING DIMENSIONS           |       |
| <b>HEIGHT</b>                | N.A.  |
| <b>DEPTH</b>                 | N.A.  |
| <b>WIDTH</b>                 | N.A.  |
| WEIGHT                       |       |
| <b>EQUIPAMENT</b>            | 75 kG |
| <b>EQUIPAMENT + PACKGING</b> | N.A.  |

Approved by: Rui Ribeiro

07/04/2019

This leaflet is merely informative, subject to changes in technical data and typographical errors, and may not be used as a contractual document.

\*Temperature on steady state, at the load line, with empty and closed equipment, at the correspondent climatic class ambient conditions.

©All Rights Reserved

Document uncontrolled after issuance

| EXPEDITION |      |      |             |
|------------|------|------|-------------|
| CAPACITY   | 20'  | 40'  | 45'   TRUCK |
|            | N.A. | N.A. | N.A.        |