

Positioning systems

Automatic format adjustment in machines –
Professional conversion to various product formats



A FAMILY-OWNED AND HIGHLY INNOVATIVE SUPPLIER OF CUSTOMISED SOLUTIONS

We offer both standardised products and customised solutions and services for mechatronics, electronics and software. With our own development department (electronics/construction) and a remarkable depth of production expertise, we are able to manufacture a wide range of variants for our customers. A strong quality assurance programme and lean processes have made us a highly professional partner with impressive performance in quality, costs and punctuality. Our quality management system is certified in accordance with **ISO 9001:2015**. We accept our environmental responsibilities in all our processes and corporate decisions – our environmental management system is also certified in accordance with **ISO 14001:2015**.

Long-standing relationships bind us closely to our customers, our approx. 130 employees, the location in Kirchzarten and our suppliers.



HALSTRUP-WALCHER: SPECIALISTS IN 4 SECTORS

MEASUREMENT TECHNOLOGY



You need to control the pressure in your cleanroom to keep contaminated air from entering. You need a display panel that shows you relevant physical/chemical parameters at a glance. You need to monitor an HVAC air filter or fan. Or you need to maintain overpressure or vacuum in one of your machines.

halstrup-walcher supplies instruments for high precision applications in the area of pressure measurement technology: Pressure transmitters, calibration devices and digital manometers for stationary or mobile use.

POSITIONING SYSTEMS



As a manufacturer of machine tools, your customers expect you to supply highly flexible solutions with minimal retooling times. Format changes should be performed automatically, with highest precision and as quickly as possible. And you want to be able to offer your customer optimum availability of the machine – supported by condition monitoring for the components.

Positioning systems from halstrup-walcher include motor, gear, absolute encoder, the motor control system with a choice of 10 different bus communications on-board along with a wide variety of designs and performance characteristics.

TAILOR-MADE DRIVE SOLUTIONS



You need to make parts move, linear or rotary. Optimised for the existing construction space and with a sharp eye on the costs. With a constantly high level of precision. With or without housing. As a motor/gearbox combination. Regulated or with a control system or as a purely mechanical solution. With analog or digital communication.

halstrup-walcher offers solutions covering every aspect of spur gearboxes and actuators. We develop mechanical designs, electronics and all the relevant stages of the manufacturing process in-house.

SERVICES



You have an application in drive technology, mechatronics or sensor systems, but can't find a suitable product.

halstrup-walcher develops and designs the solution you need. Even in small batch numbers.

You need DAkkS or ISO calibration for your measuring devices so that you can be sure they are reliable.

halstrup-walcher runs 2 accredited laboratories for DAkkS calibrations from the variables pressure and flow rate.

LEAN MANAGEMENT AT HALSTRUP-WALCHER



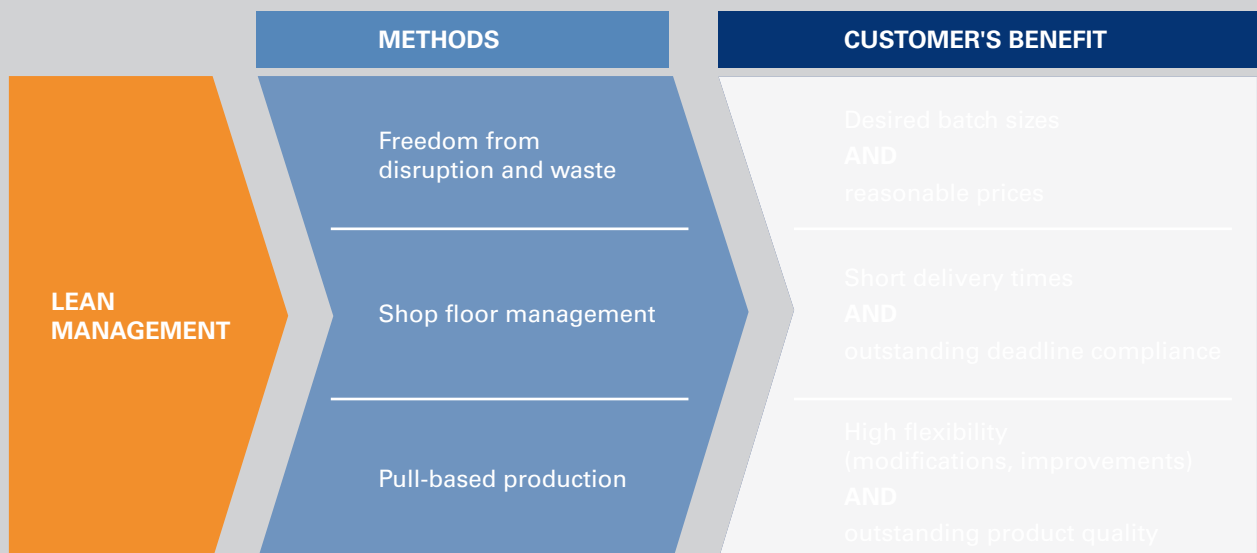

Focus on the customer and optimised internal processes

A number of years ago, business theorists spoke of a „magic triangle“ of quality (Q), costs (C) and punctuality (P). These three factors were considered magical because any measures for improvement could benefit no more than two of them at any time – and these gains could only be obtained at the expense of the third. With the help of lean management, halstrup-walcher has succeeded in breaking the spell of this *magic triangle*. Faults, disruptions and waste are eliminated systematically from all relevant processes. This liberates the whole team to concentrate fully on the real needs of our customers.

Shop floor management has also brought previously unimaginable successes. Employee consultations take place in each department every working day. These are forums for discussion of current issues. Measures for eliminating these issues immediately and permanently are discussed and agreed at follow-up meetings in the company. These take into account all the relevant information. Everyone contributes, no problem is ignored. Solutions to the problems are implemented without delay. It is a culture that has won the hearts and minds of both our staff and our customers. halstrup-walcher has now begun *exporting* its insights into lean management and offers these as a service to medium-sized enterprises.



CONTENTS

Overview of positioning systems	p. 5	
Changing format with positioning systems	p. 6	
IP protection classes and bus communication	p. 7	
Direct /indirect wiring	p. 8	
Find the right positioning system	p. 10	
The right brake	p. 11	
PSE/PSS/PSW 3 series device and software features	p. 13	
Positioning systems 2 series	p. 37	
HIPERDRIVE positioning systems	p. 39	
Analogue positioning systems	p. 44	

CONFIGURE YOUR POSITIONING SYSTEMS

Just click to go to the appropriate positioning system. Find your optimal device with our product configurator. You can then:

- view technical details
- compare products or
- make a direct request for an offer or advice.

www.halstrup-walcher.de/configurator

or

- ▶ **Navigation point: „Products“**
- ▶ **Product configurator**
- ▶ **Positioning systems**

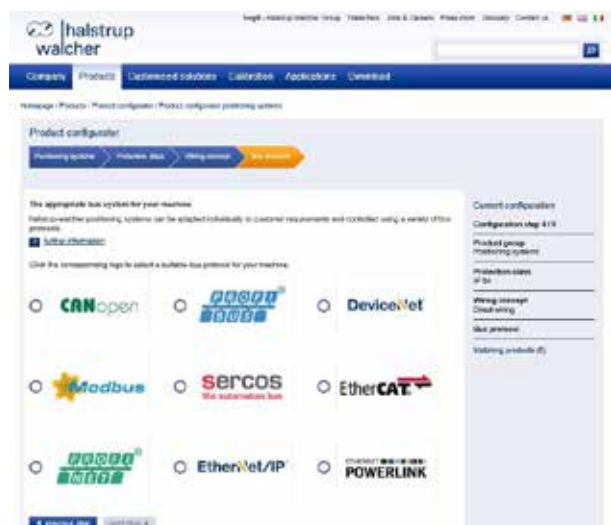

COMPARE OUR POSITIONING SYSTEMS

	PSE 3 series	PSS 3 series	PSW 3 series	PSE 34_-14	PSE 2 series	HIPERDRIVE HDA 70	PSE 441	PSE 100 / 200	PSE 272
Model ▶ page	30_-8 ▶ 20 30_/32_-14 ▶ 21 31_-8 ▶ 22 31_/33_-14 ▶ 23 3210/3218-14 ▶ 24 3310/3325-14 ▶ 25	30_-8 ▶ 28 30_/32_-14 ▶ 29 31_-8 ▶ 30 31_/33_-14 ▶ 31	30_-8 ▶ 32 30_/32_-14 ▶ 33 31_-8 ▶ 34 31_/33_-14 ▶ 35	26	37	40	42	44	45
Protection class	IP64	IP65 ¹⁾	IP68 ²⁾	IP64	IP54	IP65	IP65	IP55	IP65
Bus communication³⁾	CA, DP, DN, MB, SE, EC, PN, EI, PL, IO	CA, DP, DN, MB, SE, EC, PN, EI, PL, IO	CA, DP, SE, EC, PN, EI, PL, IO	CA, DP, SE, EC, PN, EI, PL, IO	CA, DN, MB	DP, EC, PN, EI/RS485 via Hub	RS485 via Hub/daisy chain	analog set value: 0...10V (R _L > 2 kΩ) 0/4...20 mA (R _L < 500 Ω) supply voltage: 230 VAC	
Motor	EC-motor	EC-motor	EC-motor	EC-motor	DC-motor	EC-motor	stepping motor	AC-/DC-motor	
Nominal torque	1...5 Nm (.25 Nm for PSE)	1...5 Nm (.25 Nm for PSE)	10/18 Nm	10/18 Nm	1/2 Nm	15 Nm	1.5/2.5 Nm	1...10 Nm	0.75...5 Nm
Self-holding torque	0.5...2.5 Nm (.12,5 Nm for PSE) ⁴⁾	0.5...2.5 Nm (.12,5 Nm for PSE) ⁴⁾	5...9 Nm ⁴⁾	5...9 Nm ⁴⁾	-	25 Nm	-	-	-
Nominal speed	10...230 rpm	40...210 rpm	60/80 rpm	60/80 rpm	20...80 rpm	27 rpm	10...40 rpm	0.25...30 rpm	2...60 rpm
Output shaft	8 mm hollow shaft 8/14 mm solid shaft (only for PSS/PSW)	14 mm hollow shaft with clamp and feather keyway	14 mm hollow shaft with clamp and feather keyway	14 mm hollow shaft with clamp and feather keyway	8 mm solid/hollow shaft with adjustable collar	10 mm solid shaft, 10/12 mm hollow shaft	10 mm solid shaft with feather keyway	12 mm solid shaft	8 mm solid shaft
Measurement system⁵⁾	absolute, optical-magnetic	absolute, optical-magnetic	absolute, optical-magnetic	absolute, optical-magnetic	quasi absolute, magnetic	quasi absolute, magnetic-mechanical	absolute, magnetic	absolute	absolute
Positioning range	250 rotations ⁶⁾	250 rotations ⁶⁾	250 rotations ⁶⁾	250 rotations ⁶⁾	unlimited (quasi absolute measurement system) 64 rotations (absolute measurement system)	32,000 rotations	250 rotations ⁶⁾	50 rotations (PSE 200) 20 rotations (PSE 100)	15 rotations
Jog keys	optional via jog key contacts ⁷⁾	optional via jog key contacts ⁷⁾	optional via jog key contacts ⁸⁾	optional via jog key contacts ⁸⁾	-	on board	on board	-	-
Accuracy	±0.9°	±0.9°	±0.9°	±0.9°	±0.9°	±1°	±2.5°	2% of positioning range	2% of positioning range
Manual adjustment	standard, only possible with 14 mm output shaft	standard, only possible with 14 mm output shaft	standard	standard	-	-	-	-	-
Brake⁹⁾	optional (holding brake) for 14 mm output shaft	optional (holding brake) for 14 mm output shaft	optional (friction brake)	optional (friction brake)	-	not required due to self-holding torque	-	-	-

¹⁾ under installed and wired conditions

²⁾ IP 68 at standstill, IP66 during rotation (tested with water)

³⁾ see p. 7 for bus abbreviations

⁴⁾ with current

⁵⁾ generally without battery, therefore maintenance-free

⁶⁾ without mechanical limitation

⁷⁾ not for PSW or IO-Link, always via an extra connector

⁸⁾ not for CANopen

⁹⁾ please see brake selection guide on p. 11

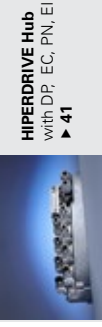

HIPERDRIVE Hub
with DP, EC, PN, EI
▶ 41

ADJUST FORMATS WITH POSITIONING SYSTEMS

Your customers want increasing flexibility in machines.

Machines and plants require minimal set-up times. Conversion is therefore automated more often as well. More and more bottlers are, for instance, demanding high flexibility when it comes to changing bottle formats: after small round ones, a quick changeover must be made to tall square bottles.

When a machine is converted, many objects are positioned on adjustment axes in the entire process: guide rails, labellers and inspection cameras. Our positioning systems adjust these axes to the new position in the control unit immediately after the demand – quickly and precisely.

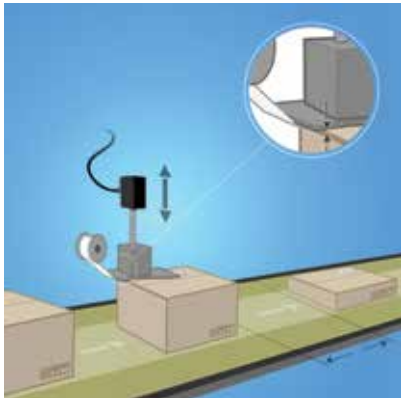

packaging machines

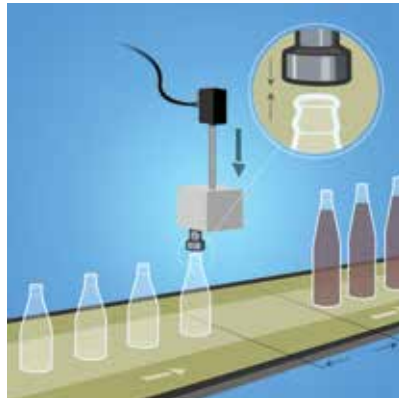

filling plants



machine tools/woodworking

Take advantage of the 3 benefits of automation

Compared to manual adjustment, automation with our positioning systems offers 3 key benefits:

- 1 **Saves time:** It is already possible for production to start in the new format just after the demand – several axes are adjusted at the same time and there is no need to wait for staff
- 2 **Increased quality:** A defined format is always adjusted the same way – the positions vary with manual adjustment
- 3 **Self-monitoring:** When there are unwanted changes to the position, the **position correction immediately** resets the desired position. Thanks to their **self-analysis** and **early warnings**, our positioning systems provide support for predictive maintenance – to improve your machine’s availability (see also page 17).

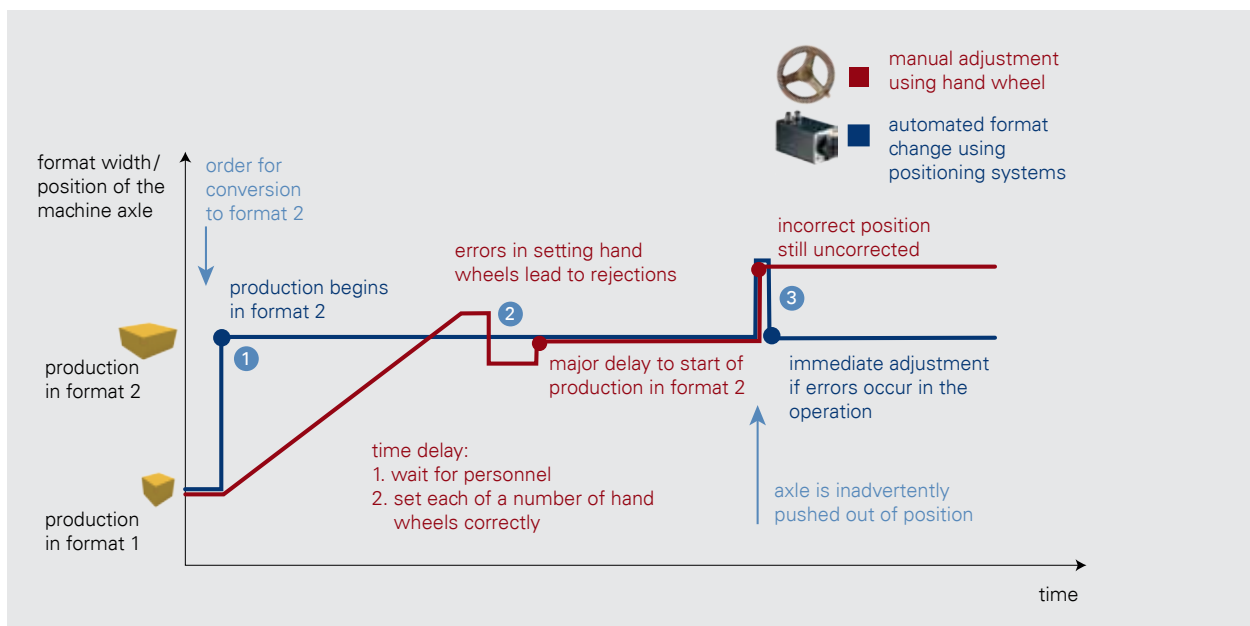

Gain time and avoid errors with automated format changeovers

FLEXIBLE PROTECTION CLASSES AND BUS COMMUNICATION

Flexibility in IP protection classes



For dry, damp or wet areas: we have the right solution for you.

The protection required by a component against penetration by moisture and dust/objects is stated using the **IP protection class** (*IP = International Protection Code*).

Many machines are used under normal manufacturing conditions and therefore require **no additional moisture protection** for the positioning system. Good resistance to dust and robust safety standards are far more important.











For applications such as these, standard devices with the protection class **IP 54** are an ideal solution.

Hygienic applications in the food processing and pharmaceutical sectors as well as other **critical applications** require a higher protection class. This is achieved by using more resistant materials (e.g. stainless steel) as well as suitably designed seals. These measures are relevant to the overall cost of the solutions, so halstrup-walcher offers devices in both the **IP 65** and **IP 68** segments.

						
PSE/PSS/PSW 3 series	PSE 3 series (E = Efficient)	p. 20-26	PSS 3 series (S = Stainless)	p. 28-31	PSW 3 series (W = Washable)	p. 32-35
HIPERDRIVE	-	-	HDA 70, Hub, PSE 441	p. 40-42	-	-
Further products	PSE 21_/23_-8 PSE 100/200 (IP55)	p. 37 p. 44	PSE272	p. 45	-	-

We speak your language: the appropriate bus system for your machine

Machinery and plant builders frequently have to demonstrate a high level of flexibility in the range of bus communication standards they offer – and meet the wishes of the machine's user. halstrup-walcher supplies the best possible support for meeting these requirements: all standard bus systems are developed and manufactured in-house and supported by our application engineers.

												RS 485 (via hub)
Abbreviation		CA	DP	DN	MB	IO	SE	EC	PN	EI	PL	
Positioning system	page											
PSE 21_/23_	37	✓		✓	✓							
PSE/PSS/PSW 30_/31_/32_/33_	20-35	✓	✓	✓	✓	✓	✓	✓	✓	✓	✓	
PSE 34_	26	✓	✓			✓	✓	✓	✓	✓	✓	
HIPERDRIVE HDA 70	40		✓					✓	✓	✓		✓
PSE 441	42											✓
HIPERDRIVE Hub	41		✓					✓	✓	✓		

FLEXIBILITY WITH WIRING

Your choice: Direct or indirect wiring via hub/gateway

You include positioning systems at various places in a machine. Wire the devices in the way that best suits your machine. You can connect our positioning systems in two ways:

1. Direct bus connection to the control unit: Line or ring wiring of all positioning drives
2. Indirect connection with interposition of a hub or gateway (= distributor) via a cable

DIRECT WIRING – SAVE SPACE AND DISTRIBUTORS

PSx 3 series

With direct wiring, bus communication occurs directly from the control unit to the positioning system, **without an additional bus distributor**. The signal is looped through a second bus connection to the next device. You thus connect the drives as **series** (CANopen, PROFI-BUS DP, DeviceNet and Modbus) or **ring** (for all Ethernet-based buses). If a component fails, further signals are provided to the control unit with a ring connection.

Another cable gives the systems their power supply. The motor and control unit are powered separately in the device. **Galvanic separation** makes constant access to bus signals possible – even if the motor power supply is interrupted, for instance by an emergency shut-down.



Advantages compared to indirect wiring:

- Save on installation space and take advantage of the positioning systems' compact design
- Save costs for additional bus distributors

HIPERDRIVE Family

The HIPERDRIVE product family also provides an option for direct wiring with the HDA 70. We install an **adapter for bus communication** in the device for that.

PSE / PSS / PSW HIPERDRIVE HDA
(with adapter)

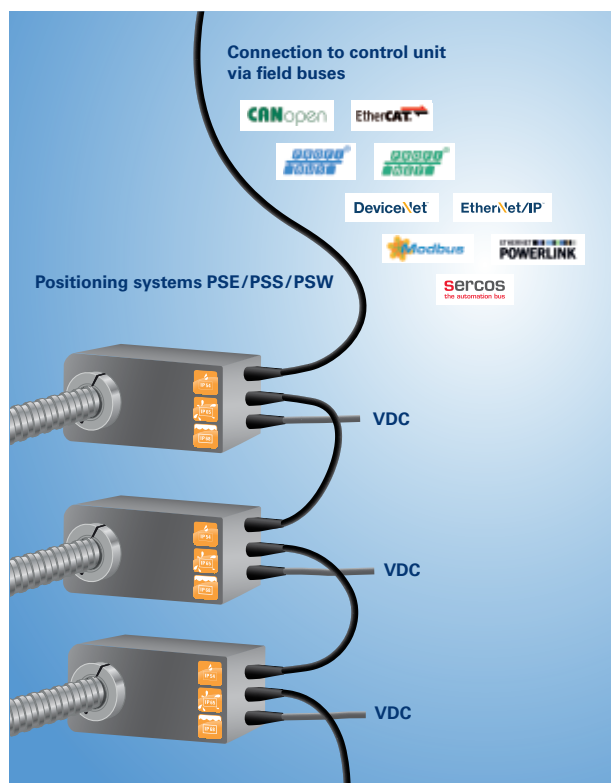
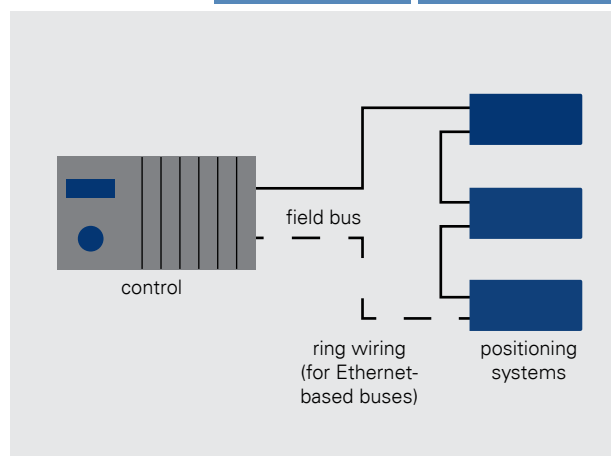

INDIRECT WIRING – SAVE TIME AND CABLES

With indirect wiring, the positioning systems are connected to the control unit via a hub/gateway.

Advantages compared to direct wiring:

- only 1 cable on the device: The positioning system's power supply and bus communication take place through the same cable.
- Machine looks tidy: nearby components are bundled and combined into one unit via a hub/gateway.

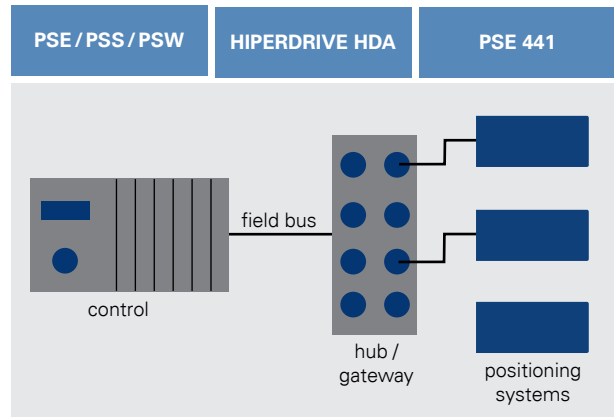

Indirect wiring of positioning system 3 series

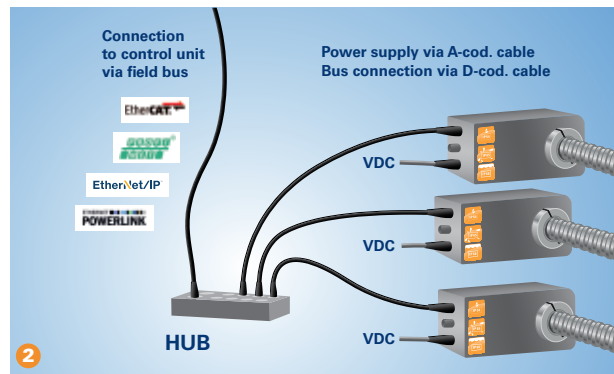
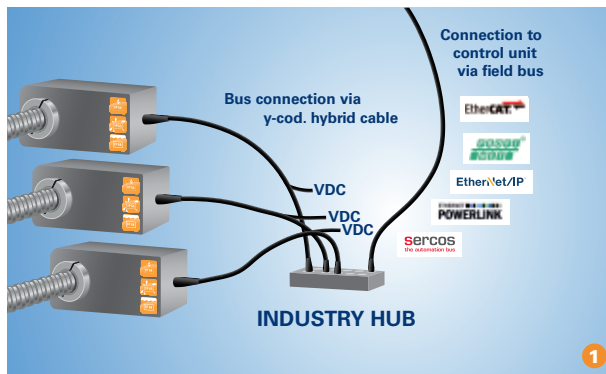

Positioning systems in the 3 series connect you to the control unit via a standard hub. Power can be supplied to the devices in 2 ways:

- 1 **1 standard Y-coded cable** is connected to the device for bus communication and power supply (**Ethernet-based buses**, other buses on request). The cable must be spliced.
- 2 A D-coded cable is connected to a hub for bus communication (**Ethernet-based buses** without Sercos). Power is supplied to the positioning systems with an A-coded cable.

For **IO-Link**, a **standard A-coded cable** is used for bus communication and power supply.



Indirect wiring of HIPERDRIVE family

The HDA 70 and PSE 441 are connected to the control unit via the **HIPERDRIVE hub**. The hub controls up to 8 drives and has **power fuses**. The control cabinet is thus relieved.

The hub converts the bus commands into standard signals. If bus communication is changed, the HIPERDRIVE positioning systems can remain unchanged. Only the hub has to be changed. Time-consuming alterations and stock keeping are thus minimised.



FIND THE RIGHT POSITIONING SYSTEM

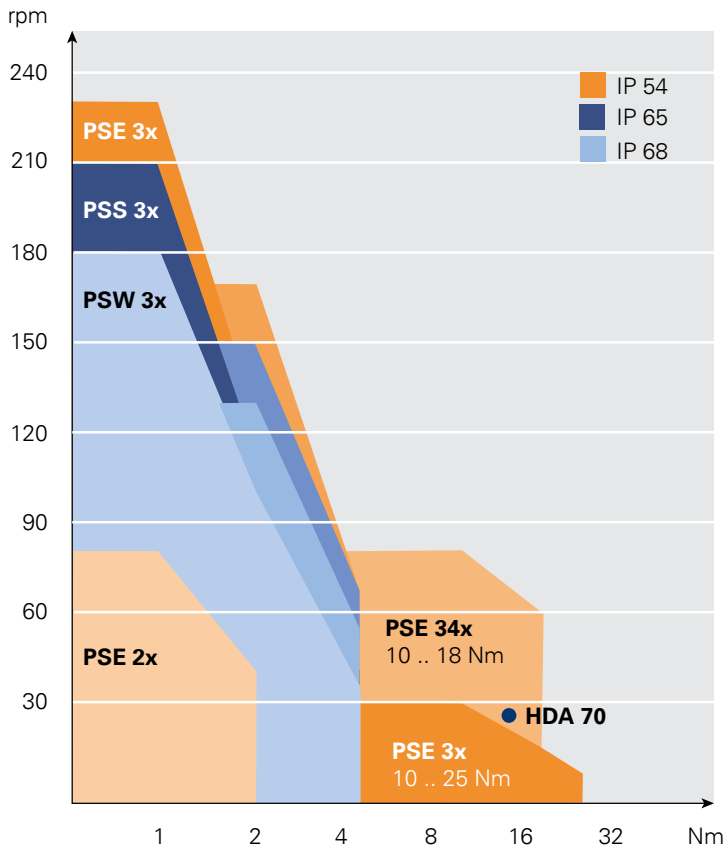

You already know your torque / speed range and are looking for the appropriate model.

For example you require the protection class IP54 and a maximum torque of 2 Nm. The speed should be greater than 100 rpm.

→ PSE 3

This graphic always shows the nominal torque-nominal rated speed combinations for the halstrup-walcher positioning systems. It is intended to provide an initial guide and enable you to find the correct positioning systems based on the required torque range.

CALCULATE THE TORQUE

(relevant for vertical positioning)

You know the mass to be positioned and are looking for the appropriate torque when making a vertical adjustment?

The following "back-of-an-envelope" calculation allows you to calculate the approx. torque required. But it does not consider the torque requirement with friction. Another option (for machines that are already operational) is to measure the actual value using a torque measurement device.

$$\text{torque } M \text{ [Nm]} \quad (\text{if unknown}) = \frac{m \text{ [kg]} \times s \text{ [mm]}}{630} \times T$$

$T = 1.1$ for ball screw spindle
 $= 3.3$ for trapezoidal threaded spindle

Example: mass m : 50 kg, spindle pitch s : 4 mm, T : trapezoidal threaded spindle

$$\text{torque } M \text{ [Nm]} = \frac{50 \text{ kg} \times 4 \text{ mm}}{630} \times 3.3 \text{ Nm} = 1.04 \text{ Nm}$$

→ A positioning system with 2 Nm torque should be selected. (30% reserve)

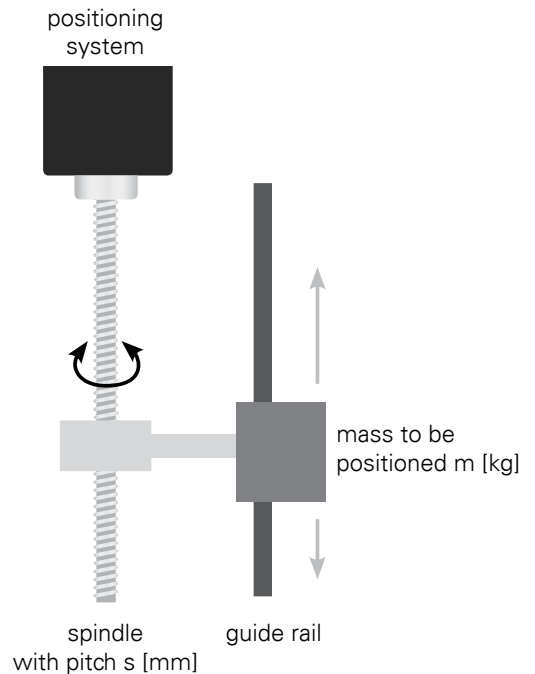

THE RIGHT BRAKE FOR VERTICAL APPLICATIONS

Selection of the appropriate brake *(relevant for vertical positioning)*

When objects have to be positioned vertically (i.e. moved up and down), it should not be forgotten that gravity continues to act when they are at rest. There are various requirements here: The position must be maintained at least approximately for safety reasons. Some applications also require the position to always be maintained precisely even when the power supply is switched off. The various possibilities are given below.

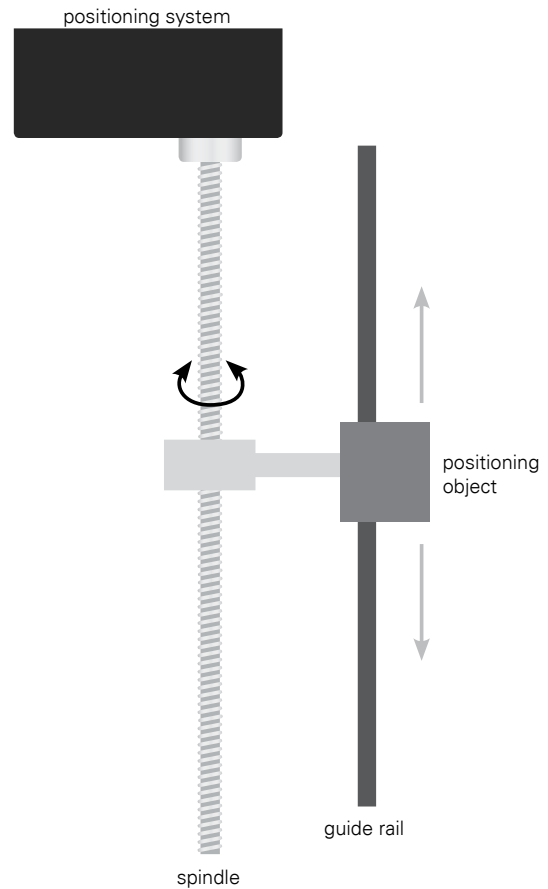

Please note the following situations and solutions:

	Requirement	Solution	Technical description
1.	Object needs not to be held in position when power supply is switched off.	<ul style="list-style-type: none"> PSE/PSS/PSW without optional brake, with ball screw 	<ul style="list-style-type: none"> Self-holding torque acts when power supply is active When the power supply is switched off, the object is not held in position (no braking effect)
2.	Object must be held in approximate position when the power supply is switched off. ¹⁾	<ul style="list-style-type: none"> PSE/PSS/PSW 3_-14 with optional hand brake (holding brake) or PSE 34_-14 with integrated retarder (friction brake) 	<ul style="list-style-type: none"> Mechanically held in approximate¹⁾ position
3.	Object must be held exactly in position even when the power supply is switched off.	<ul style="list-style-type: none"> HIPERDRIVE HDA 70 due to very high self-holding torque PSE/PSS/PSW without optional brake, but with trapezoidal threaded spindle instead of ball screw spindle PSE/PSS/PSW with external, e.g. pneumatic brake 	<ul style="list-style-type: none"> Mechanically held in the exact position

¹⁾ < 0,5 mm

POSITIONING SYSTEMS 3 SERIES

PSE



PSS



PSW



PSE / PSS / PSW

THE COMPACT AND FUTURE-PROOF SYSTEM SOLUTION

Your machine needs minimal set-up times with high repeating accuracy and optimum availability. Do you want to be flexible with bus communication and IP protection? Have you also got space you can't afford to lose?

halstrup-walcher has been supplying positioning systems to well-known machinery and equipment manufacturers for over 10 years. The experience we have gathered has been integrated into two new series – PSS (IP 65) and PSW (IP 68) – which complement our successful PSE (IP 54) range. All three series are **interchangeable** in terms of their *connection dimensions* and they are available with a wide range of *different bus systems*.

The 3 series positioning system combines precise positioning with **unrivalled compactness**.

All the functions are integrated into a very small space (as shown in these 3D illustrations). The systems manage **without additional bus distributors**, saving you space and money.

Important information for you as a partner: Not only are the electronics and mechanical systems developed in-house, they are also manufactured in-house – from the gear wheels to the SMD circuit boards. Because we never compromise on quality!

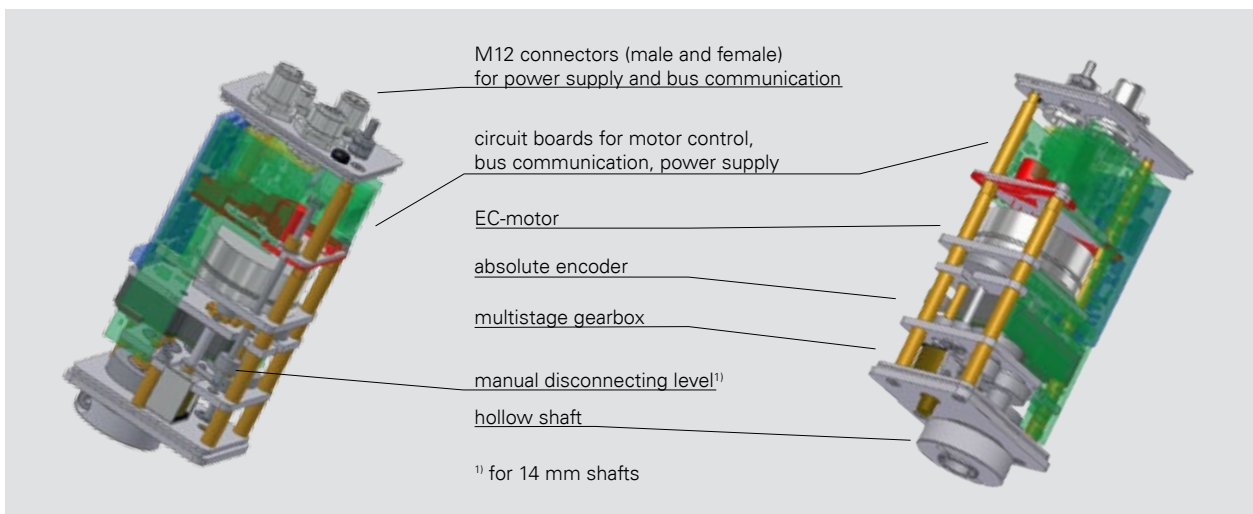

1 machine concept – in 3 IP classes and with 10 buses

Our **comprehensive construction kit system** lets you adapt both the bus communication and IP protection class to customer wishes. In the process, the relevant dimensions do not change. This generates noticeable savings for you when altering and adapting products for customer-specific machines.

We have designed a universal product family for all **3 relevant IP protection classes**: IP 54 (PSE), IP 65 (PSS) and IP 68 (PSW). You can say goodbye to bulky covering boxes for higher IP protection classes. These are welcome advantages for any mechanical engineer – especially considering the restricted size of the installation spaces available.



ABSOLUTE MEASUREMENT SYSTEM

The PSE / PSS / PSW positioning system **always knows** its exact position:

- Absolute measurement system **right on the output shaft**
- **No battery** – no maintenance costs
- **No positioning errors** even if the power supply is interrupted
- **No reference run** – no time wasted

Measured by the halstrup-walcher combination encoder on the basis of:

- 1. the number of total rotations** ($n \times 360^\circ$),
 - ▶ 250 rotations are recorded (not mechanically limited)
 - ▶ 8 bit encoder (optical)
 - ▶ error = 0 (pure counting function)
- 2. the degrees of angle of the last rotation**
 - ▶ 400 increments per rotation (magnetic)
 - ▶ error = max. 1 increment per 360° , i.e. between 0° and **0.9° total error**



POSITIONING ACCURACY

Because any error is only contributed by the “*last rotation*” (max. 0.9° of 360°), the error contribution x in the position is:

$$\frac{0.9^\circ}{360^\circ} = \frac{x}{5 \text{ mm}} \rightarrow x = \text{max. } 0.0125 \text{ mm (spindle pitch 5 mm)}$$

$$\frac{x}{4 \text{ mm}} \rightarrow x = \text{max. } 0.0100 \text{ mm (spindle pitch 4 mm)}$$

In practice, there is also an error contribution associated with inconsistencies in the spindle.

The **encoder** is located on the output shaft, which prevents additional errors due to gear backlash.

→ Optimum precision for all positioning applications

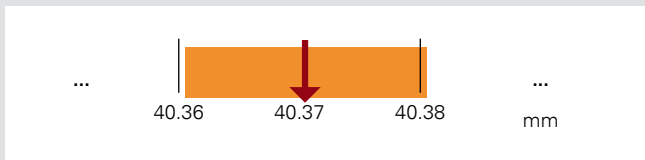

STAY SAFE EVEN WHEN PROBLEMS OCCUR

The motor and control units have separate power supplies and are galvanically separated. This prevents problems due to interferences being passed on from the motor to the control unit. It also guarantees that bus communication remains available even during an **emergency stop**; it is still possible to read out the status and current actual position.

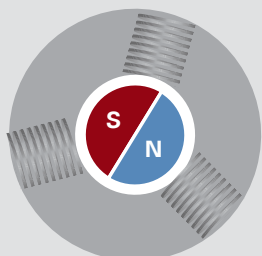
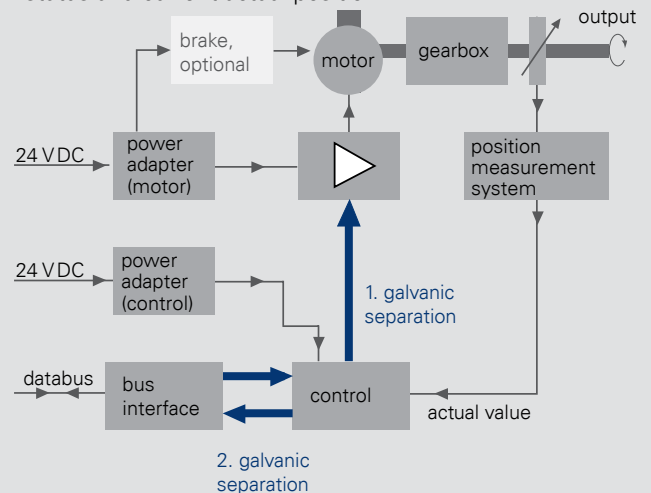

EC-MOTOR

Durable in every detail. Our positioning drives should be robust and durable. This is why we always use high quality brushless EC-motors, which do not wear and which drive the positioning system accurately.

STATUS LED



Recognise the current status. Status LEDs always show the positioning system's current status. Errors are signalled without looking into the control unit.

EASY MOUNTING WITH HOLLOW SHAFT

Mechanical adaptations with minimal effort. The output shaft of the positioning system has to be adapted to the application. A hollow shaft with an adjustable collar has proven itself an effective and reliable solution for this task. Torque support is also very easily implemented using a pin. This eliminates the need for a coupling with intermediate flange, which would result in additional costs, longer assembly times and, above all, requires more space.

Mounting with hollow shaft

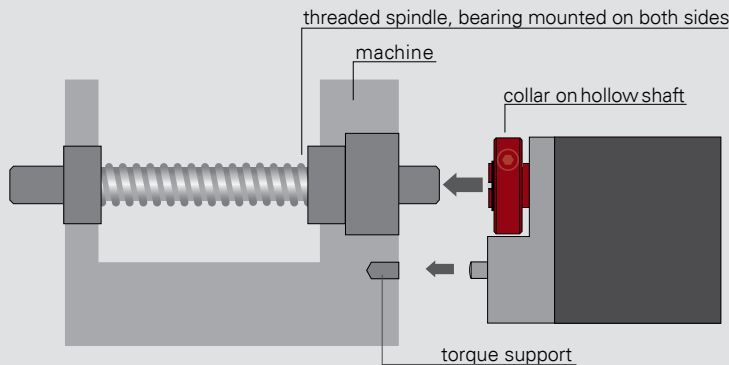

Mounting with solid shaft and coupling

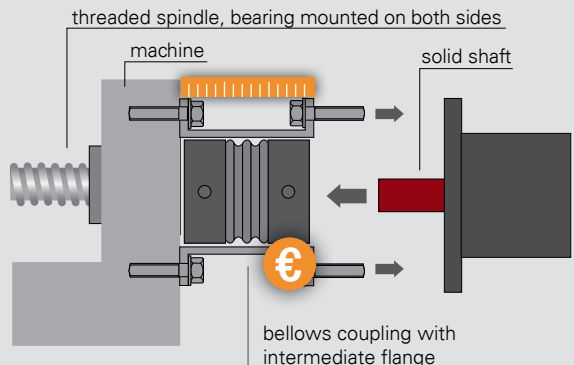

FAST SET-UP

To set up the system or a replacement, simply install the unit and assign the address using the address selection switches – the positioning system immediately receives all the parameters from the predecessor unit via the control. The absolute encoder removes the need for a reference run.

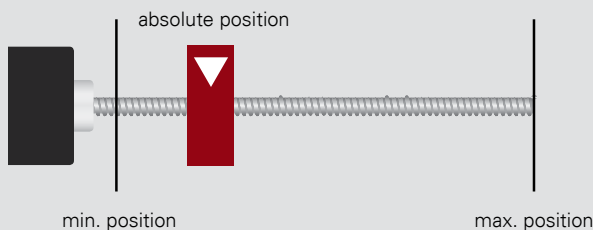

ADDRESS SWITCHES ¹⁾

Addressing – right on the device

Usually, customers wish to be able to set the address of the individual positioning system directly on the device itself. This avoids the confusion and mistakes that can occur when addresses are set via the control unit. It also simplifies the process of setting the address manually when a device is replaced during servicing or maintenance work.

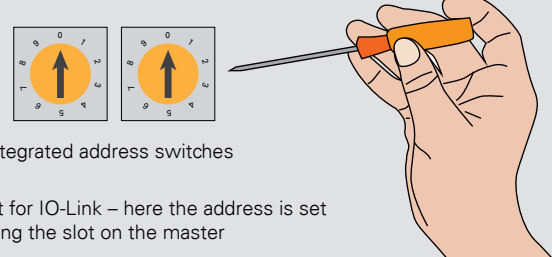

¹⁾ not for IO-Link – here the address is set using the slot on the master

JOG KEY OPERATION ²⁾

Simplifying setup.

When the machine is being set up, the required zero position must first be measured and then programmed into the control. Often, the optimum position is approached in a number of increments. Jog key operation simplifies this process. Using two direction controls, the user can quickly proceed to the appropriate zero position either on-site or using the control panel without the need for bus communication. The PSx 3 series ³⁾ has optional jog key contacts, which can be activated via the machine panel, for example.

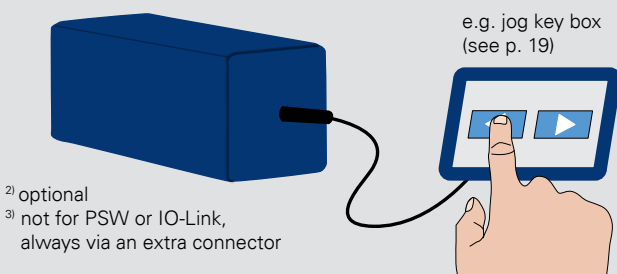

²⁾ optional
³⁾ not for PSW or IO-Link, always via an extra connector

MANUAL ADJUSTMENT ⁴⁾

Manual gearbox adjustment.

Sometimes it is necessary for the user to be able to turn the spindle connected to the positioning system manually. Here, the manual disconnecting lever is used to disconnect the brake and a pinion is then coupled to it for manual adjustment. The gearbox can then be adjusted using a key/wrench.

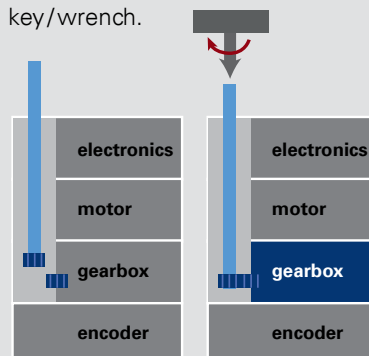

⁴⁾ standard for 14 mm shafts, not for 8 mm shafts

LIMITING TORQUE

The PSx 3 series is capable of **regulating the torque** so that it does not exceed the threshold value specified in the customer parameters:

- effective overload prevention (gearbox, application,...)
- temporary peak torque levels are deliberately permitted (to avoid unnecessary run aborts)

The motor stops if the load is too high according to specific conditions!

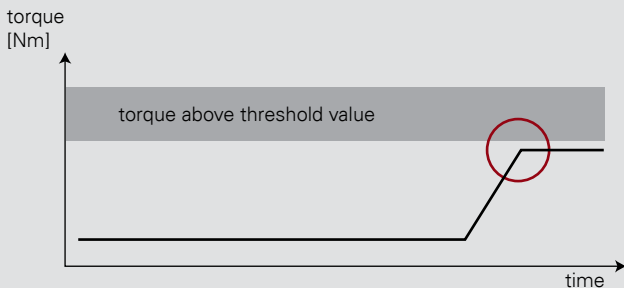

STRONG BREAKAWAY TORQUE

Safe startup even after extended standstills.

Machines are not necessarily in continuous use. Sometimes there can be extended periods of inactivity that impair the normal ease of running. When it is time for the machine to start up again, it requires a higher "breakaway torque."

The PSx series of positioning systems offers this capability, which is significantly higher than the nominal torque!

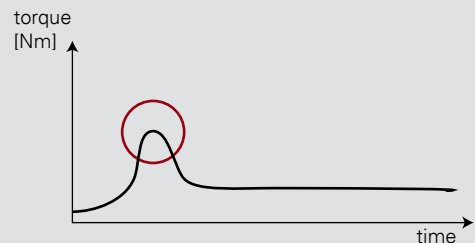

THE DIFFERENCE BETWEEN OBSTACLES AND DIRT

Intelligent running behaviour.

In practice, it is always possible that the rotation of the spindle can be obstructed in some way. In the most extreme case, this can be "running into an obstruction", e.g. if the object to be positioned has reached its mechanical limit position. However, dirt or dust on the spindle can cause it to run less easily.

In practical applications, it is important to be able to differentiate between these two scenarios: When the system detects a genuine obstruction it should stop immediately. If the problem is dirt, it should accelerate in order to overcome the blockage effectively. The PSx series of positioning systems can differentiate between these two scenarios within milliseconds and react accordingly.

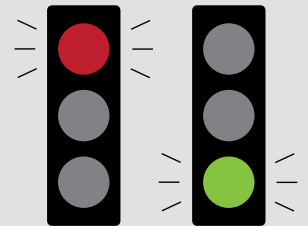

SPINDLE OFFSET RUN

Excluding inconsistencies due to lash in the spindle.

Due to dirt or slight inaccuracies, every spindle has a certain element of lash which becomes noticeable during changes in direction. For this reason, the positioning system can be parameterised to ensure that the target position is always approached from the same side (in the diagram: from the left). This eliminates the effect of spindle lash on positioning accuracy. Naturally, the process is monitored to prevent running into an obstruction.

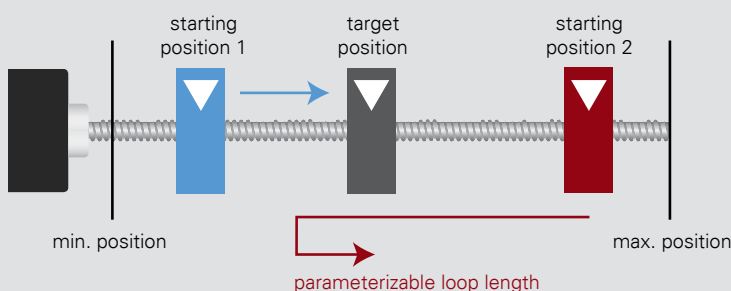

WELL SYNCHRONISED

Parallel movement of an object by two positioning systems.

If two positioning systems are required to move a broad or heavy object, they must be perfectly synchronised to avoid tipping.

The PSx series of positioning systems has been performing this task reliably in many applications for years. It is achieved through the use of a very fast drag error control unit. Find out more on the next page.

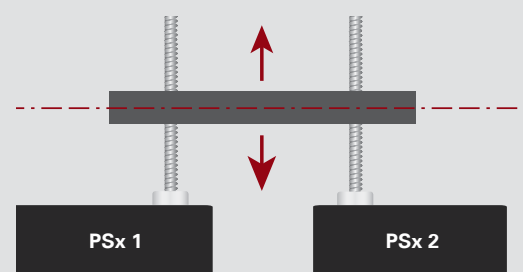

The availability of the machine is critical – and this is supported by condition monitoring.

The machine's central control unit detects problems before they occur and enables technicians to take prompt action. Numerous diagnostic messages are therefore generated in the 3 series positioning systems for predictive maintenance of machinery. A selection of these are presented on this page.



TEMPERATURE MONITORING

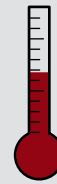

The temperature is also monitored to protect the drive and components. If this is exceeded or fallen short of, the motor is shut down.

SUPPLY VOLTAGE

Continuous monitoring of the voltage level.

If situations involving excessive or insufficient voltage occur regularly, the causes should be thoroughly investigated. The PSx series of positioning systems are programmed to ignore very short "spikes" but report all overvoltage or undervoltage events that exceed a specified duration. This enables the operator to detect errors in the supply chain before they cause damage or standstills.

voltage

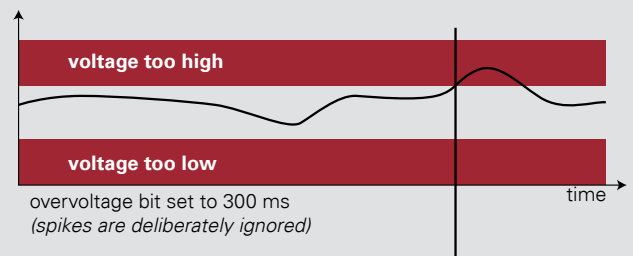

NO DRAG ERRORS

Optimum adjustment of the actual position in accordance with the specified target position is one of the key quality features of the positioning systems in the PSx 3 series. If the control unit detects that one positioning system is falling behind, it accelerates it in order to minimise "drag errors". This ensures that the two systems are well synchronised, as shown on p. 16. The drag error monitor is also used to provide early warnings. Dirt can make it impossible to reach the target position within a specified time. This situation is also passed on to the control unit directly as a "condition monitoring" message.

distance

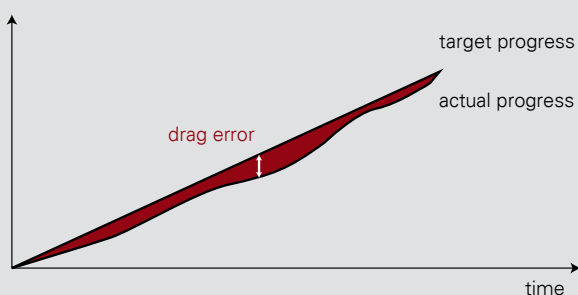

CONTINUOUS MONITORING OF POWER CONSUMPTION AND TORQUE

Monitoring these important values can prevent the positioning system being overloaded. It also allows the application to be protected in specific ways, e.g. against the effects of excessive torque. In principle, any deviation from the normal progress stored in the control unit can provide an indication of a malfunction – this makes it possible actively to avoid problem situations and damage to equipment. Wear and tear of the spindle is also detected.

torque

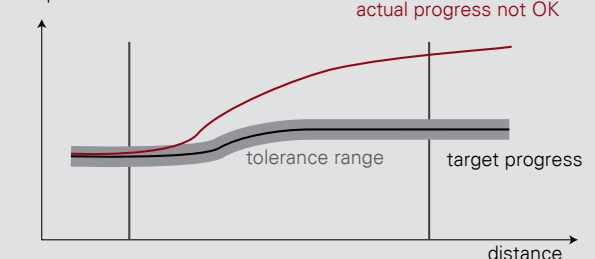

ORDER KEY PSE/PSS/PSW 3 SERIES

All the positioning systems in the PSE/PSS/PSW 3 series share the same order key.

To provide the best possible overview and to simplify customer documentation, the diverse range of options available for the PSE/PSS/PSW 3 series has been organised in a shared order key.



Order key
PSE/PSS/PSW:

	Pro-tection class	A Design	B Type	C Bus communication (see p. 7)	D Connections	E Brake (see p. 11)	F Certification
Positioning System Efficient (see p. 20-25) ¹⁾	IP 54	PSE		CA: CANopen DP: PROFIBUS DP DN: DeviceNet	0: without jog keys T: with jog keys ³⁾		0: N: NRTL certification (in accordance with UL, CSA, ANSI and CE)
Positioning System Stainless (see p. 28-31)	IP 65	PSS	30x-8/-14 (V) ²⁾ 31x-8/-14 (V) ²⁾ 32x-14 (V) ²⁾ 33x-14 (V) ²⁾	MB: Modbus RTU SE: Sercos EC: EtherCAT PN: PROFINET EI: EtherNet/IP PL: POWERLINK IO: IO-Link	Y: 1 connector, Y-encoded Z: 1 connector, Y-encoded, with jog keys ³⁾	0: without M ⁴⁾ : with	
Positioning System Washable (see p. 32-35)	IP 68	PSW					

¹⁾ You can find the order key for the PSE 34_-14 on page 26.

²⁾ (V) not for PSE

³⁾ not for PSW or IO-Link, always via an extra connector

⁴⁾ only with 14 mm output shafts

Standard equipment (Connections)

- second databus connection always provided (not for IO-Link or Y-encoded connector)
- address switches always provided (also IE-buses, not for IO-Link)

For further information on connections and address settings see also "Overview: bus communication" on p.47.

Form/Type	Torque	Output shaft
horizontal	30	8 = 8 mm hollow shaft
vertical	31	14 = 14 mm hollow shaft
horizontal	32	8V = 8 mm solid shaft ⁶⁾
vertical	33	14V = 14 mm solid shaft ⁶⁾

⁵⁾ only for PSE
18 Nm: horiz.
25 Nm: long.

⁶⁾ only for PSS/PSW

Examples of orders provided below.

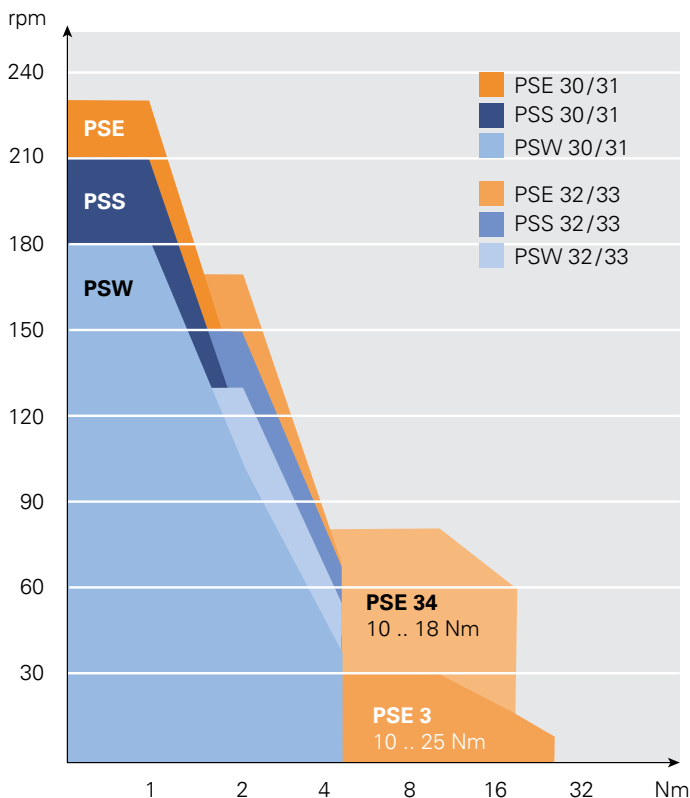

Nominal torque - nominal speed combinations

TORQUES AND SPEEDS

Example 1

You require the protection class IP54 and a maximum torque of 2 Nm. The speed should be greater than 100 rpm. An 8 mm hollow shaft and longitudinal construction meet the requirements of your application.

Your wish to use EtherNet/IP as the bus and connect the PSE to the control unit using a hybrid connector and hub. You do not require an additional holding brake in your application.

→ PSE 312-8-EI-Y-0-0







Example 2

IP 68, max. 3 Nm, > 100 rpm, horizontal construction, 14 mm solid circular shaft, IO-Link via a connector, with brake.

→ PSW 325-14V-IO-0-M-0

ACCESSORIES PSE/PSS/PSW 3 SERIES

The connectors shown here can be used for all three types of device (PSE/PSS/PSW). This ensures that the PSE (IP54) and PSS (IP65) comply with the IP protection classes. We will also be pleased to help you find a suitable mating connector for the PSW (IP68) if necessary – just ask us!

Bus communication	Power supply + databus connector (2x) (for option 0) ¹⁾	Power supply + databus (2x) + jog key connector ²⁾ (for option T) ¹⁾	Cable and connectors for 1-connector solution ³⁾ (for option Y or IO) ¹⁾			
CANopen						
PROFIBUS DP				Connector set: Order no. 9601.0060	Connector set: Order no. 9601.0062	5 m: Order no. 9601.0245 10 m: Order no. 9601.0233 20 m: Order no. 9601.0234
Modbus RTU				Connector set: Order no. 9601.0088	Connector set: Order no. 9601.0090	
DeviceNet						
Sercos				Connector set: Order no. 9601.0112	Jog key box: Order no. 9601.0241	5 m: Order no. 9601.0240 10 m: Order no. 9601.0244
EtherCAT						Hub on request
PROFINET						
EtherNet/IP						
POWERLINK						
IO-Link ³⁾	-	-				
			Connector: Order no. 9601.0107 ³⁾			

¹⁾ see under "D" in the order key ²⁾ not for PSW ³⁾ power supply and bus via one cable, without second databus connector

PSS/PSW: OPTIMUM HYGIENIC DESIGN



Our stainless steel positioning systems follows the **hygienic design** recommendations (construction design, selection and treatment of materials) of the Chair of Apparatus and Plant Design at the Technical University of Munich, Weihenstephan Science Centre.



Screw cap to cover the second bus connection (for PSS/PSW)
Order no. 9601.0176

MODULES AND DESCRIPTION FILES

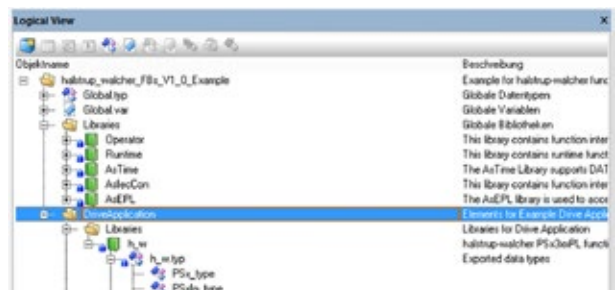

Take advantage of our functional modules or description files for the various buses. You can download the files on our website:

www.halstrup-walcher.de/en/software



Product	Nominal torque	Self-holding torque	Nominal rated speed
PSE 301-8	1 Nm	0.5 Nm	210 rpm
PSE 302-8	2 Nm	1 Nm	115 rpm
PSE 305-8	5 Nm	2.5 Nm	40 rpm

Data interfaces

CANopen, PROFIBUS DP, DeviceNet, Modbus RTU, Sercos, EtherCAT, PROFINET, EtherNet/IP, POWERLINK, IO-Link

Start-up duration	30 % (basis time 300 s)
Mode of operation	S3
Supply voltage	24 VDC \pm 10 % galvanically separated between control and motor and bus
Nominal current	2.2 A
Power consumption (control unit)	0.1 A
Positioning accuracy absolute measurement of position taken directly at the output shaft	0.9°
Positioning range	250 rotations not subject to mechanical limits
Shock resistance in accordance with IEC/DIN EN 60068-2-27	50g 11 ms
Vibration resistance in accordance with IEC/DIN EN 60068-2-6	10..55 Hz 1.5 mm / 55..1 000 Hz 10g / 10..2 000 Hz 5g
Output shaft	8 mm hollow shaft with adjustable collar
Maximum axial force	20 N
Maximum radial force	40 N
Ambient temperature	0..45°C
Storage temperature	-10..70°C
Protection class	IP 54
Weight	650g
Certificates	CE, optional: NRTL (UL, CSA, ANSI)

The order key and accessories can be found on p. 18 / 19.

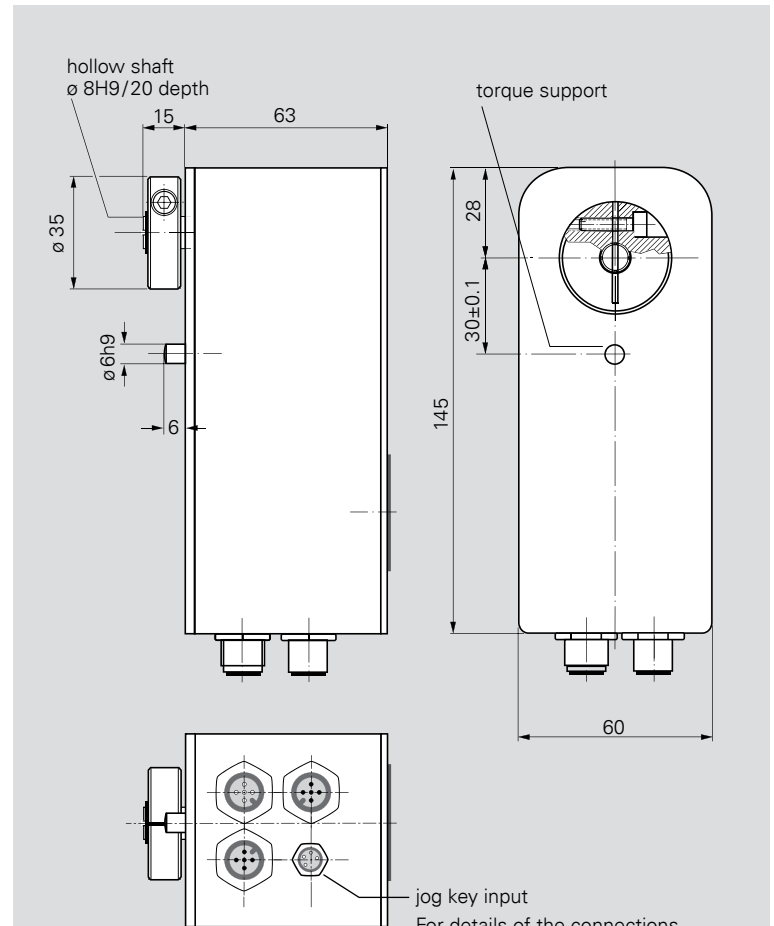

jog key input
For details of the connections please see also p. 47 and the instruction manual.

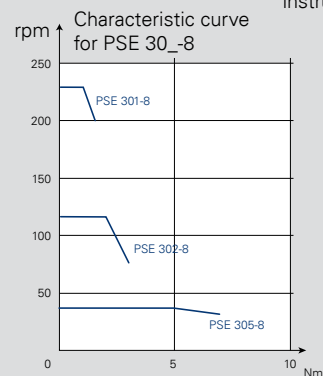

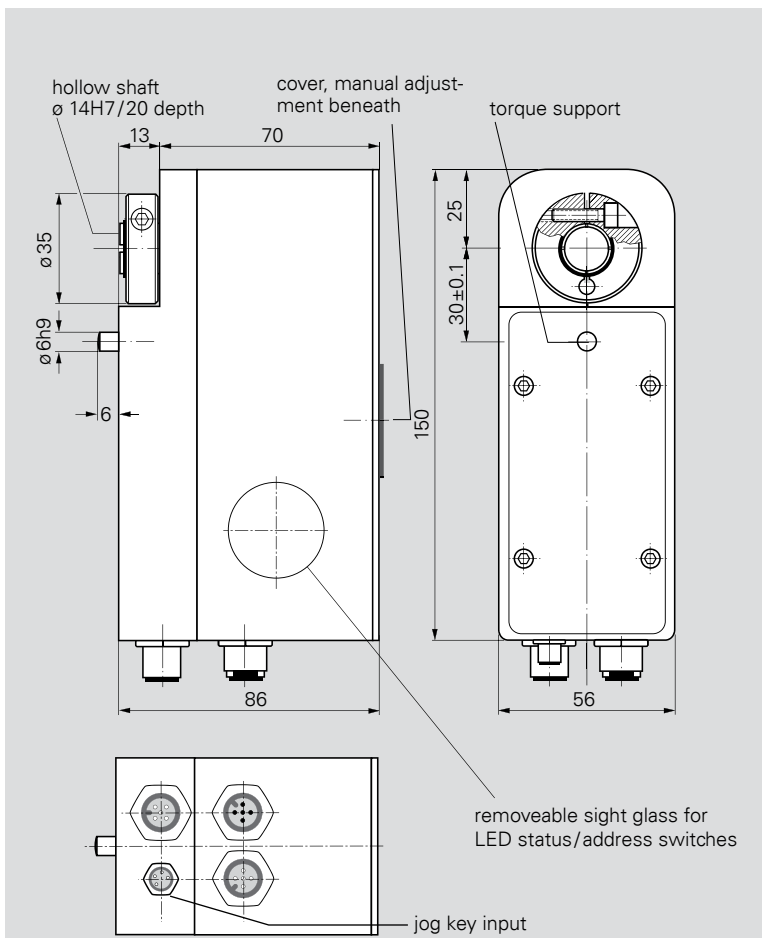

For details of the connections please see also p. 47 and the instruction manual.

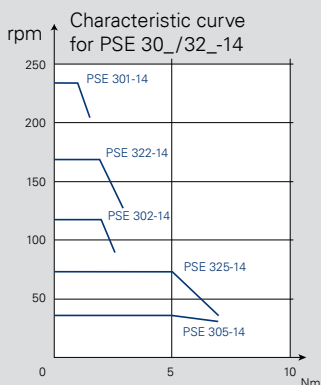

Product	Nominal torque	Self-holding torque	Nominal rated speed
PSE 301-14	1 Nm	0.5 Nm	210 rpm
PSE 302-14	2 Nm	1 Nm	100 rpm
PSE 305-14	5 Nm	2.5 Nm	40 rpm
PSE 322-14	2 Nm	1 Nm	150 rpm
PSE 325-14	5 Nm	2.5 Nm	68 rpm

Data interfaces
 CANopen, PROFIBUS DP, DeviceNet, Modbus RTU, Sercos, EtherCAT, PROFINET, EtherNet/IP, POWERLINK, IO-Link

Start-up duration	30 % (basis time 300s)
Mode of operation	S3
Supply voltage	24 VDC \pm 10 % galvanically separated between control and motor and bus
Nominal current	PSE 30_: 2.4 A, PSE 32_: 3.1 A
Power consumption (control unit)	0.1 A
Positioning accuracy absolute measurement of position taken directly at the output shaft	0.9°
Positioning range	250 rotations not subject to mechanical limits
Shock resistance in accordance with IEC/DIN EN 60068-2-27	50g 11 ms
Vibration resistance in accordance with IEC/DIN EN 60068-2-6	10..55 Hz 1.5 mm/ 55..1 000 Hz 10 g/ 10..2 000 Hz 5 g
Output shaft	14 mm hollow shaft with adjustable collar
Maximum axial force	20 N
Maximum radial force	40 N
Ambient temperature	0..45°C
Storage temperature	-10..70°C
Protection class	IP54
Weight	1 200 g
Certificates	CE, optional: NRTL (UL, CSA, ANSI)

The order key and accessories can be found on p. 18/19.



Product	Nominal torque	Self-holding torque	Nominal rated speed
PSE 311-8	1 Nm	0.5 Nm	210 rpm
PSE 312-8	2 Nm	1 Nm	115 rpm
PSE 315-8	5 Nm	2.5 Nm	40 rpm

Data interfaces

CANopen, PROFIBUS DP, DeviceNet, Modbus RTU, Sercos, EtherCAT, PROFINET, EtherNet/IP, POWERLINK, IO-Link

Start-up duration	30 % (basis time 300 s)
Mode of operation	S3
Supply voltage	24 VDC \pm 10 % galvanically separated between control and motor and bus
Nominal current	2.2 A
Power consumption (control unit)	0.1 A
Positioning accuracy absolute measurement of position taken directly at the output shaft	0.9°
Positioning range	250 rotations not subject to mechanical limits
Shock resistance in accordance with IEC/DIN EN 60068-2-27	50g 11 ms
Vibration resistance in accordance with IEC/DIN EN 60068-2-6	10..55 Hz 1.5 mm / 55..1 000 Hz 10g / 10..2 000 Hz 5g
Output shaft	8 mm hollow shaft with adjustable collar
Maximum axial force	20 N
Maximum radial force	40 N
Ambient temperature	0..45°C
Storage temperature	-10..70°C
Protection class	IP 54
Weight	700g
Certificates	CE, optional: NRTL (UL, CSA, ANSI)

The order key and accessories can be found on p. 18 / 19.

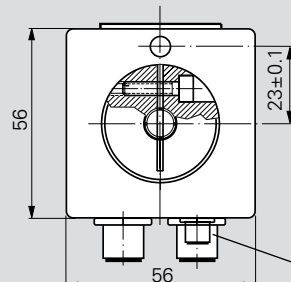
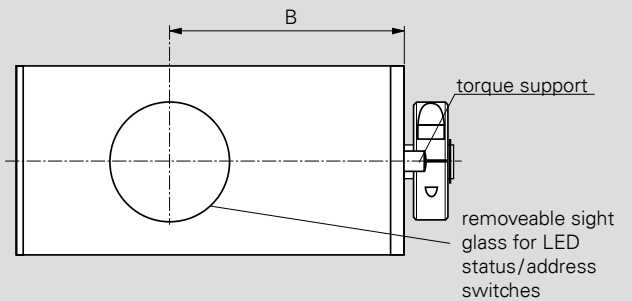
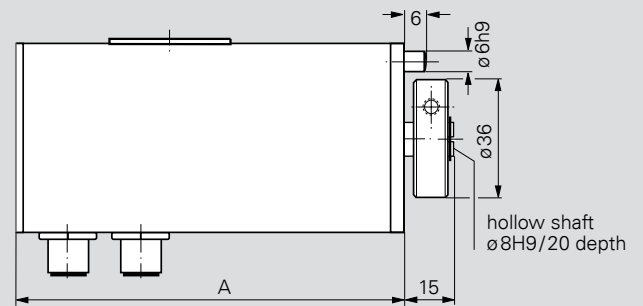

	A	B
PSE 311	115	70
PSE 312	127	82
PSE 315		

For details of the connections please see also p. 47 and the instruction manual.

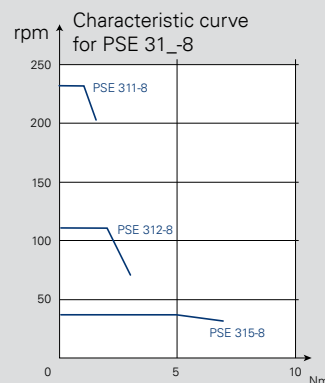



hollow shaft $\varnothing 14H7/20$ depth

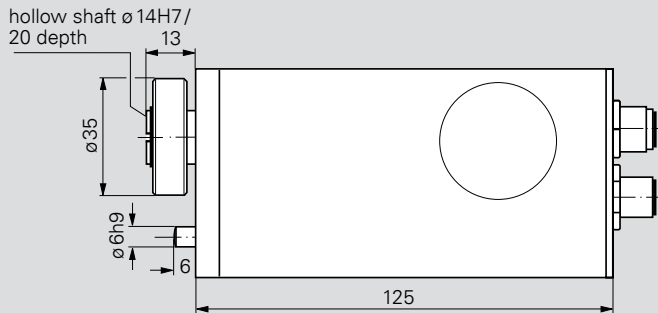

jog key input

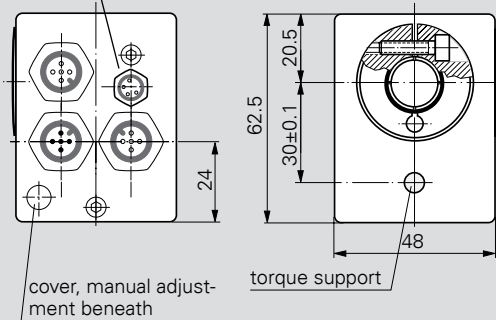

For details of the connections please see also p. 47 and the instruction manual.

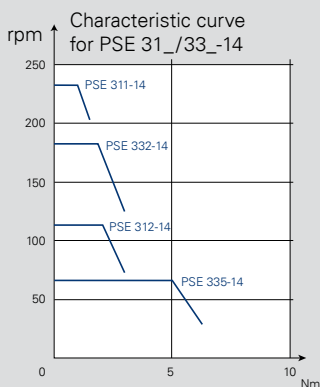

Product	Nominal torque	Self-holding torque	Nominal rated speed
PSE 311-14	1 Nm	0.5 Nm	210 rpm
PSE 312-14	2 Nm	1 Nm	115 rpm
PSE 332-14	2 Nm	1 Nm	150 rpm
PSE 335-14	5 Nm	2.5 Nm	68 rpm

Data interfaces

CANopen, PROFIBUS DP, DeviceNet, Modbus RTU, Sercos, EtherCAT, PROFINET, EtherNet/IP, POWERLINK, IO-Link

Start-up duration	30 % (basis time 300 s)
Mode of operation	S3
Supply voltage	24 VDC $\pm 10\%$ galvanically separated between control and motor and bus
Nominal current	PSE 31_: 2.4 A, PSE 33_: 3.1 A
Power consumption (control unit)	0.1 A
Positioning accuracy	0.9° absolute measurement of position taken directly at the output shaft
Positioning range	250 rotations not subject to mechanical limits
Shock resistance	50g 11 ms in accordance with IEC/DIN EN 60068-2-27
Vibration resistance	10..55 Hz 1.5 mm/ 55..1 000 Hz 10 g/ 10..2 000 Hz 5 g in accordance with IEC/DIN EN 60068-2-6
Output shaft	14 mm hollow shaft with adjustable collar
Maximum axial force	20 N
Maximum radial force	40 N
Ambient temperature	0..45°C
Storage temperature	-10..70°C
Protection class	IP54
Weight	700 g
Certificates	CE, optional: NRTL (UL, CSA, ANSI)

The order key and accessories can be found on p. 18 / 19.



Product	Nominal torque	Self-holding torque	Nominal rated speed
PSE 3210-14	10 Nm	5 Nm	30 rpm
PSE 3218-14	18 Nm	9 Nm	17 rpm

Data interfaces
CANopen, PROFIBUS DP, DeviceNet, Modbus RTU, Sercos, EtherCAT, PROFINET, EtherNet/IP, POWERLINK, IO-Link

Start-up duration	30 % (basis time 300 s)
Mode of operation	S3
Supply voltage	24 VDC \pm 10 % galvanically separated between control and motor and bus
Nominal current	3.1 A
Power consumption (control unit)	0.1 A
Positioning accuracy absolute measurement of position taken directly at the output shaft	0.9°
Positioning range	250 rotations not subject to mechanical limits
Shock resistance in accordance with IEC/DIN EN 60068-2-27	50 g 11 ms
Vibration resistance in accordance with IEC/DIN EN 60068-2-6	10 .. 55 Hz 1.5 mm/ 55 .. 1 000 Hz 10 g/ 10 .. 2 000 Hz 5 g
Output shaft	14 mm hollow shaft with clamp and feather key
Maximum axial force	20 N
Maximum radial force	40 N
Ambient temperature	0 .. 45 °C
Storage temperature	-10 .. 70 °C
Protection class	IP54
Weight	approx. 1350 g
Certificates	CE, optional: NRTL (UL, CSA, ANSI)

The order key and accessories can be found on p. 18/19.

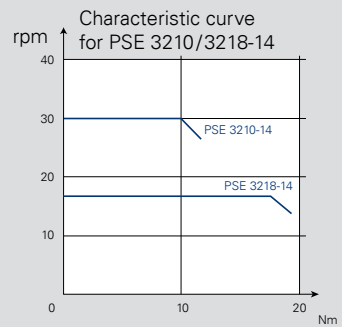
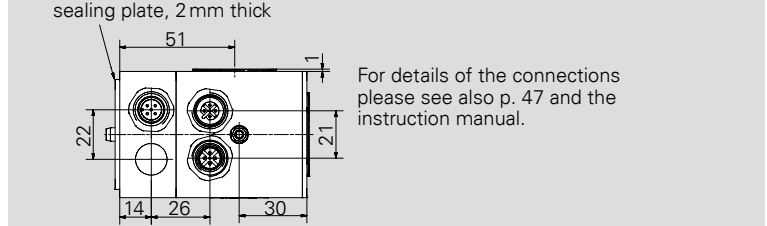
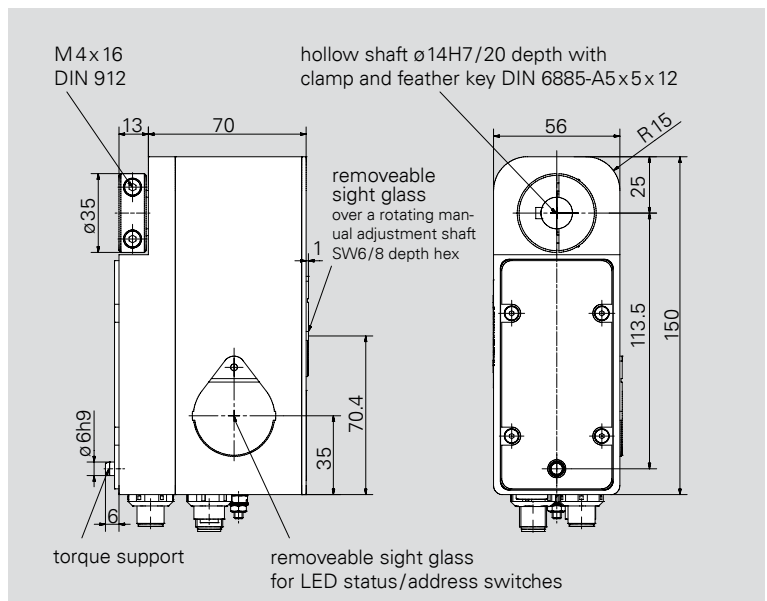



CE
 Typ PSE3325-14-OP-0-M
 Drehmoment 25 Nm
 Drehzahl 10 U/min
 Stelbereich 250 U
 Spannung 24 VDC
 9433.0094 AD-60795
 halstrup walcher

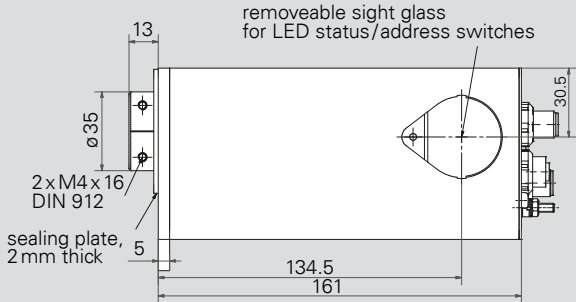

hollow shaft $\varnothing 14H7/20$ depth with clamp and feather key DIN 6885-A5x5x12

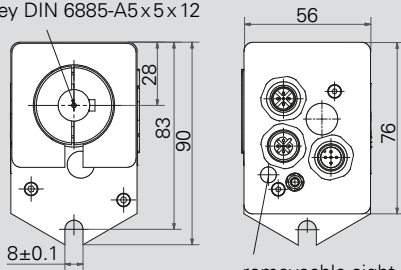

removeable sight glass over a rotating manual adjustment shaft SW3 depth hex

For details of the connections please see also p. 47 and the instruction manual.

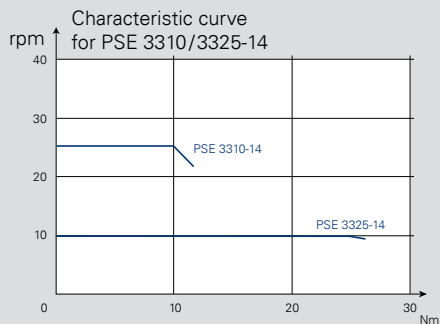

Product	Nominal torque	Self-holding torque	Nominal rated speed
PSE 3310-14	10 Nm	5 Nm	25 rpm
PSE 3325-14	25 Nm	12,5 Nm	10 rpm

Data interfaces
 CANopen, PROFIBUS DP, DeviceNet, Modbus RTU, Sercos, EtherCAT, PROFINET, EtherNet/IP, POWERLINK, IO-Link

Start-up duration	25 % (basis time 300s)
Mode of operation	S3
Supply voltage	24 VDC $\pm 10\%$ galvanically separated between control and motor and bus
Nominal current	3.1 A
Power consumption (control unit)	0.1 A
Positioning accuracy absolute measurement of position taken directly at the output shaft	0.9°
Positioning range	250 rotations not subject to mechanical limits
Shock resistance in accordance with IEC/DIN EN 60068-2-27	50 g 11 ms
Vibration resistance in accordance with IEC/DIN EN 60068-2-6	10..55 Hz 1.5 mm/ 55 .. 1 000 Hz 10 g/ 10 .. 2 000 Hz 5 g
Output shaft	14 mm hollow shaft with clamp and feather key
Maximum axial force	20 N
Maximum radial force	40 N
Ambient temperature	0..45°C
Storage temperature	-10..70°C
Protection class	IP54
Weight	1350 g
Certificates	CE, optional: NRTL (UL, CSA, ANSI)

The order key and accessories can be found on p. 18 / 19.

Start-up duration	20 % (basis time 300 s)
Mode of operation	S3
Supply voltage	24 VDC \pm 10 % galvanically separated between control and motor and bus
Nominal current	7.8 A
Power consumption (control unit)	0.1 A
Positioning accuracy absolute measurement of position taken directly at the output shaft	0.9°
Positioning range	250 rotations not subject to mechanical limits
Shock resistance in accordance with IEC/DIN EN 60068-2-27	50 g 11 ms
Vibration resistance in accordance with IEC/DIN EN 60068-2-6	10 .. 55 Hz 1.5 mm / 55 .. 1 000 Hz 10 g / 10 .. 2 000 Hz 5 g
Output shaft	14 mm hollow shaft with clamp and feather key
Maximum axial force	20 N
Maximum radial force	40 N
Ambient temperature	0 .. 45 °C
Storage temperature	-10 .. 70 °C
Protection class	IP54
Weight	1900 g
Certificates	CE

Nominal torque	Self-holding torque	Nominal rated speed	A
10 Nm	5 Nm	80 rpm	3410-14
18 Nm	9 Nm	60 rpm	3418-14

Data interfaces	B
CANopen	CA
PROFIBUS DP	DP
Sercos	SE
EtherCAT	EC
PROFINET	PN
EtherNet/IP	EI
POWERLINK	PL
IO-Link	IO

Connections ¹⁾	C
without jog keys	0
with jog keys ¹⁾	T

¹⁾ not for CANopen

Brake	D
no brake	0
with brake (holding torque is the same as the nominal torque)	M

Order code	A	B	C	D
PSE	-	-	-	-

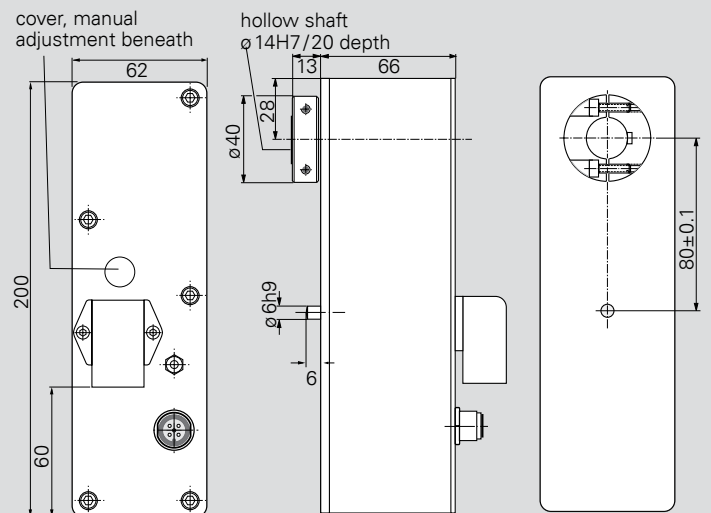

For details of the connections please see also p. 47 and the instruction manual.

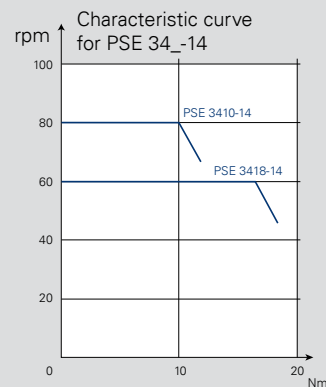

AUTOMATED FORMAT CHANGEOVERS SUPPORT INDUSTRY 4.0

in self-monitoring and networked machines

10

buses

X

3

IP protection classes

=

1

MODULAR
SOLUTION

for every machine concept

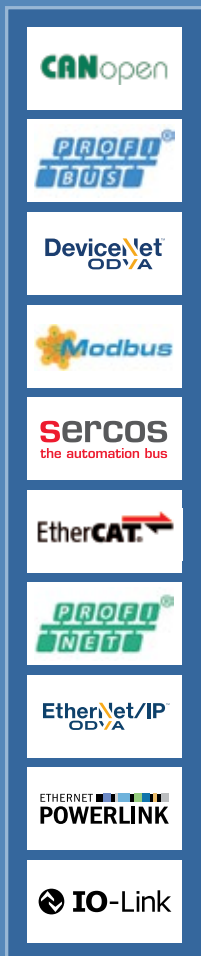

X



=

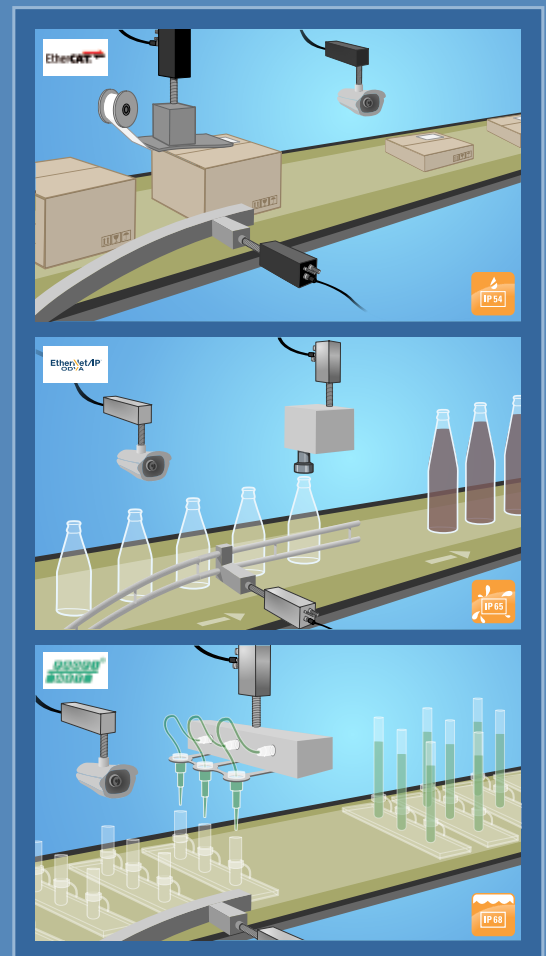

Flexible machine design with positioning systems

- **Intelligent drives** with an integrated motor, gearbox, motor control, on-board communication, absolute encoder and condition monitoring.
- Kit with various designs, torques, protection classes and bus protocols
- Machinery can be flexibly tailored to customer requirements – without changing the relevant dimensions



Product	Nominal torque	Self-holding torque	Nominal rated speed
PSS 301-8	1 Nm	0.5 Nm	210 rpm
PSS 302-8	2 Nm	1 Nm	115 rpm
PSS 305-8	5 Nm	2.5 Nm	40 rpm

Data interfaces

CANopen, PROFIBUS DP, DeviceNet, Modbus RTU, Sercos, EtherCAT, PROFINET, EtherNet/IP, POWERLINK, IO-Link

Start-up duration	20 % (basis time 600s) at nominal torque
Mode of operation	S3
Supply voltage	24 VDC \pm 10 % galvanically separated between control and motor and bus
Nominal current	2.2 A
Power consumption (control unit)	0.1 A
Positioning accuracy absolute measurement of position taken directly at the output shaft	0.9°
Positioning range	250 rotations not subject to mechanical limits
Shock resistance in accordance with IEC/DIN EN 60068-2-27	50 g 11 ms
Vibration resistance in accordance with IEC/DIN EN 60068-2-6	10..55 Hz 1.5 mm / 55..1 000 Hz 10 g / 10..2 000 Hz 5 g
Output shaft	8 mm solid shaft or 8 mm hollow shaft with adjustable collar
Maximum axial force	20 N
Maximum radial force	40 N
Ambient temperature	0..45 °C
Storage temperature	-10..70 °C
Protection class	IP65 under installed and wired conditions ¹⁾
Material	as for PSE, but with stainless steel housing
Weight	650 g
Certificates	CE, optional: NRTL (UL, CSA, ANSI)

¹⁾ welded V2A housing, ball bearings at the output shaft with sealing disc

The order key and accessories can be found on p. 18 / 19.

PSS 30_-8 (with hollow shaft)

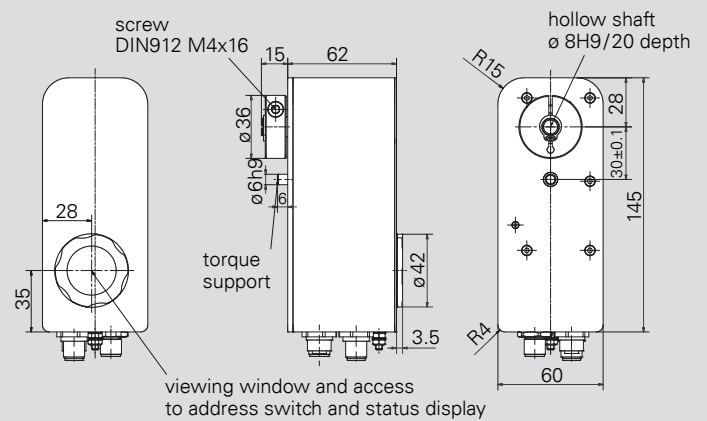

PSS 30_-8-V (with solid shaft)

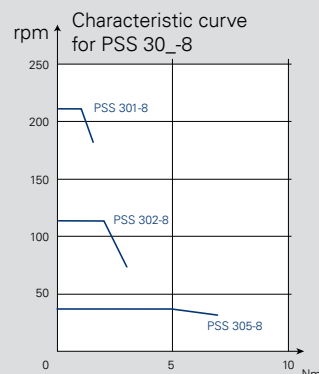
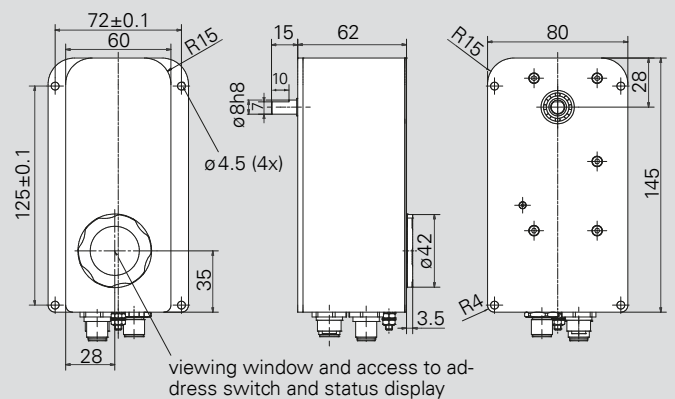

For details of the connections please see also p. 47 and the instruction manual.



PSS 30_/32_-14 (with hollow shaft)

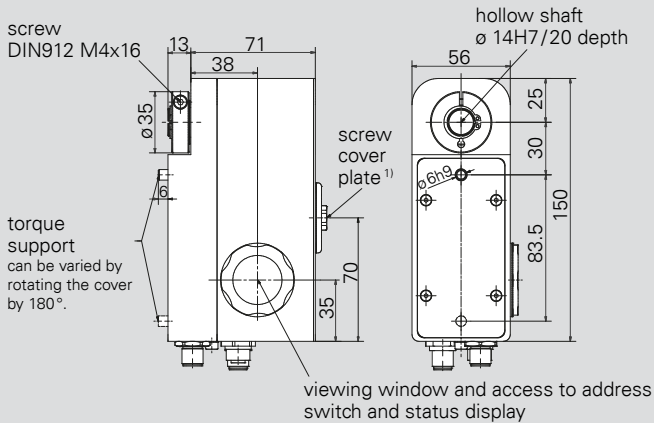

PSS 30_/32_-14-V (with solid shaft)

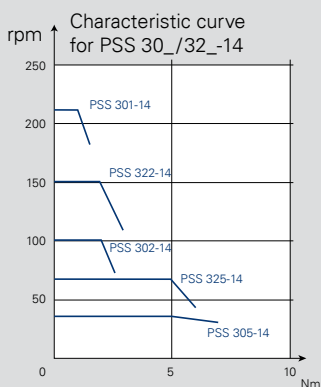
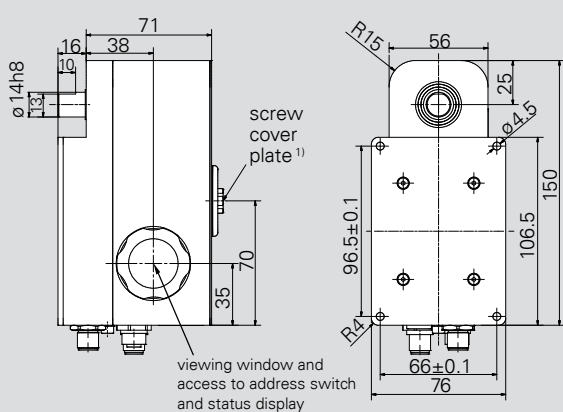

For details of the connections please see also p. 47 and the instruction manual.

¹⁾ over a rotating manual adjustment shaft SW6/8 depth hex

Product	Nominal torque	Self-holding torque	Nominal rated speed
PSS 301-14	1 Nm	0.5 Nm	210 rpm
PSS 302-14	2 Nm	1 Nm	100 rpm
PSS 305-14	5 Nm	2.5 Nm	40 rpm
PSS 322-14	2 Nm	1 Nm	150 rpm
PSS 325-14	5 Nm	2.5 Nm	68 rpm

Data interfaces
 CANopen, PROFIBUS DP, DeviceNet, Modbus RTU, Sercos, EtherCAT, PROFINET, EtherNet/IP, POWERLINK, IO-Link

Start-up duration	20 % (basis time 600s) at nominal torque
Mode of operation	S3
Supply voltage	24 VDC \pm 10 % galvanically separated between control and motor and bus
Nominal current	PSS 30_: 2.4 A, PSS 32_: 3.1 A
Power consumption (control unit)	0.1 A
Positioning accuracy absolute measurement of position taken directly at the output shaft	0.9°
Positioning range	250 rotations not subject to mechanical limits
Shock resistance in accordance with IEC/DIN EN 60068-2-27	50 g 11 ms
Vibration resistance in accordance with IEC/DIN EN 60068-2-6	10..55 Hz 1.5 mm/ 55..1 000 Hz 10 g/ 10..2 000 Hz 5 g
Output shaft	14 mm solid shaft or 14 mm hollow shaft with adjustable collar
Maximum axial force	20 N
Maximum radial force	40 N
Ambient temperature	0..45 °C
Storage temperature	-10..70 °C
Protection class	IP65 under installed and wired conditions ²⁾
Material	as for PSE, but with stainless steel housing
Weight	1 200 g
Certificates	CE, optional: NRTL (UL, CSA, ANSI)

²⁾ welded V2A housing, ball bearings at the output shaft with sealing disc

The order key and accessories can be found on p. 18/21.



Product	Nominal torque	Self-holding torque	Nominal rated speed
PSS 311-8	1 Nm	0.5 Nm	210 rpm
PSS 312-8	2 Nm	1 Nm	115 rpm
PSS 315-8	5 Nm	2.5 Nm	40 rpm

Data interfaces
 CANopen, PROFIBUS DP, DeviceNet, Modbus RTU, Sercos, EtherCAT, PROFINET, EtherNet/IP, POWERLINK, IO-Link

Start-up duration	20 % (basis time 600 s) at nominal torque
Mode of operation	S3
Supply voltage	24 VDC ± 10 % galvanically separated between control and motor and bus
Nominal current	2.2 A
Power consumption (control unit)	0.1 A
Positioning accuracy absolute measurement of position taken directly at the output shaft	0.9°
Positioning range	250 rotations not subject to mechanical limits
Shock resistance in accordance with IEC/DIN EN 60068-2-27	50 g 11 ms
Vibration resistance in accordance with IEC/DIN EN 60068-2-6	10..55 Hz 1.5 mm / 55..1 000 Hz 10 g / 10..2 000 Hz 5 g
Output shaft	8 mm solid shaft or 8 mm hollow shaft with adjustable collar
Maximum axial force	20 N
Maximum radial force	40 N
Ambient temperature	0..45 °C
Storage temperature	-10..70 °C
Protection class	IP65 under installed and wired conditions ¹⁾
Material	as for PSE, but with stainless steel housing
Weight	700 g
Certificates	CE, optional: NRTL (UL, CSA, ANSI)

¹⁾ welded V2A housing, ball bearings at the output shaft with sealing disc

The order key and accessories can be found on p. 18 / 19.

PSS 31_-8 (with hollow shaft)

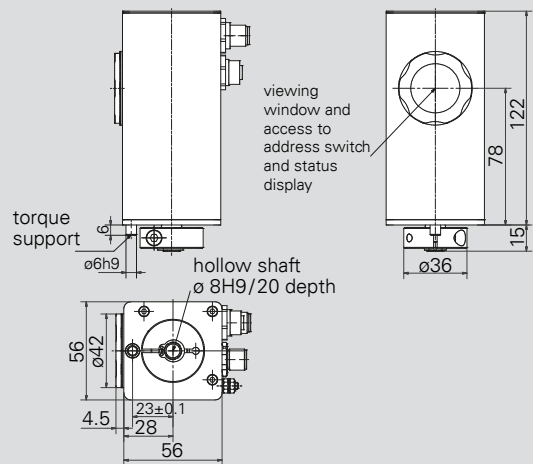

PSS 31_-8-V (with solid shaft)

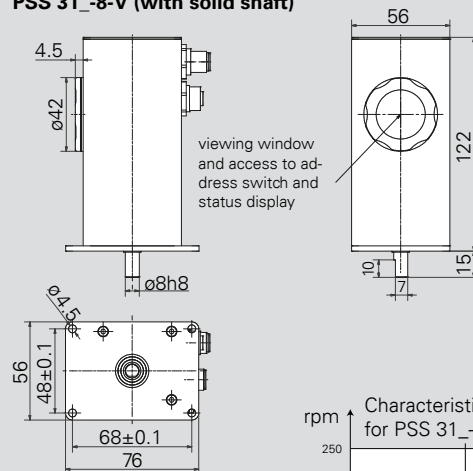

For details of the connections please see also p. 47 and the instruction manual

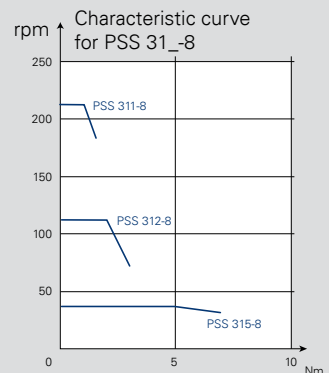



PSS 31_/33_-14 (with hollow shaft)

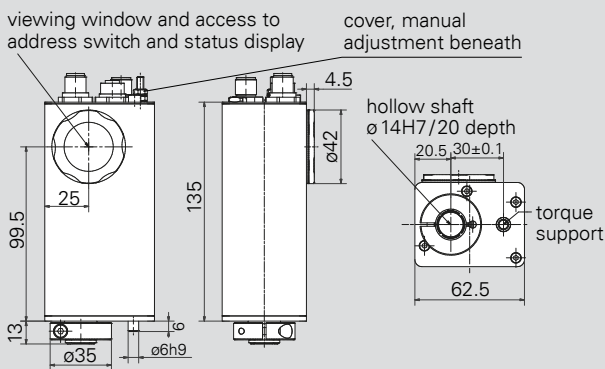

PSS 31_/33_-14-V (with solid shaft)

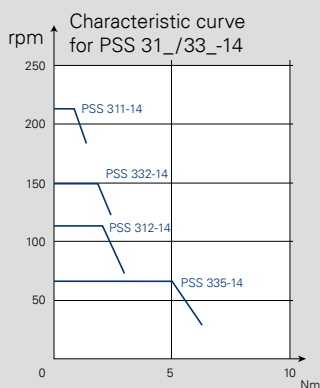
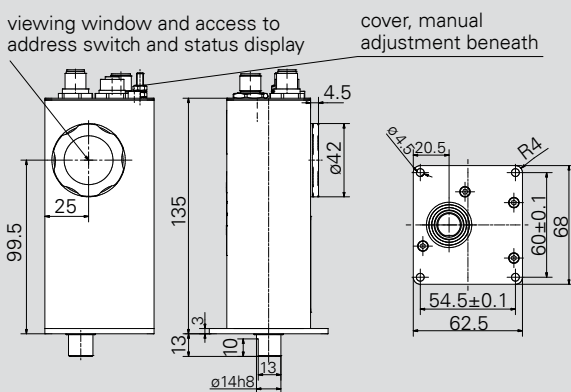

For details of the connections please see also p. 47 and the instruction manual

Product	Nominal torque	Self-holding torque	Nominal rated speed
PSS 311-14	1 Nm	0.5 Nm	210 rpm
PSS 312-14	2 Nm	1 Nm	115 rpm
PSS 332-14	2 Nm	1 Nm	150 rpm
PSS 335-14	5 Nm	2.5 Nm	68 rpm

Data interfaces

CANopen, PROFIBUS DP, DeviceNet, Modbus RTU, Sercos, EtherCAT, PROFINET, EtherNet/IP, POWERLINK, IO-Link

Start-up duration	20 % (basis time 600 s) at nominal torque
Mode of operation	S3
Supply voltage	24 VDC ± 10 % galvanically separated between control and motor and bus
Nominal current	PSS 31_: 2.4 A, PSS 33_: 3.1 A
Power consumption (control unit)	0.1 A
Positioning accuracy	0.9° absolute measurement of position taken directly at the output shaft
Positioning range	250 rotations not subject to mechanical limits
Shock resistance	50 g 11 ms in accordance with IEC/DIN EN 60068-2-7
Vibration resistance	0..55 Hz 1.5 mm / 55..1000 Hz 10 g / 10..2000 Hz 5 g in accordance with IEC/DIN EN 60068-2-6
Output shaft	14 mm solid shaft or 14 mm hollow shaft with adjustable collar
Maximum axial force	20 N
Maximum radial force	40 N
Ambient temperature	0..45 °C
Storage temperature	-10..70 °C
Protection class	IP65 under installed and wired conditions ¹⁾
Material	as for PSE, but with stainless steel housing
Weight	700 g
Certificates	CE, optional: NRTL (UL, CSA, ANSI)

¹⁾ welded V2A housing, ball bearings at the output shaft with sealing disc



Product	Nominal torque	Self-holding torque	Nominal rated speed
PSW 301-8	1 Nm	0.5 Nm	180 rpm
PSW 302-8	2 Nm	1 Nm	100 rpm
PSW 305-8	5 Nm	2.5 Nm	35 rpm

Data interfaces
 CANopen, PROFIBUS DP, DeviceNet, Modbus RTU, Sercos, EtherCAT, PROFINET, EtherNet/IP, POWERLINK, IO-Link

Start-up duration	20 % (basis time 600 s) at nominal torque
Mode of operation	S3
Supply voltage	24 VDC ± 10 % galvanically separated between control and motor and bus
Nominal current	2.2 A
Power consumption (control unit)	0.1 A
Positioning accuracy absolute measurement of position taken directly at the output shaft	0.9°
Positioning range	250 rotations not subject to mechanical limits
Shock resistance in accordance with IEC/DIN EN 60068-2-27	50 g 11 ms
Vibration resistance in accordance with IEC/DIN EN 60068-2-6	10..55 Hz 1.5 mm / 55..1 000 Hz 10 g / 10..2 000 Hz 5 g
Output shaft	8 mm solid shaft or 8 mm hollow shaft with adjustable collar
Maximum axial force	20 N
Maximum radial force	40 N
Ambient temperature	0..45 °C
Storage temperature	-10..70 °C
Protection class	IP 68 at standstill ¹⁾ , IP 66 during rotation (tested with water) ¹⁾
Material	stainless steel
Weight	650 g
Certificates	CE, optional: NRTL (UL, CSA, ANSI)

¹⁾ welded V2A housing, output shaft sealed with quad-ring

The order key and accessories can be found on p. 18 / 19.

PSW 30_-8 (with hollow shaft)

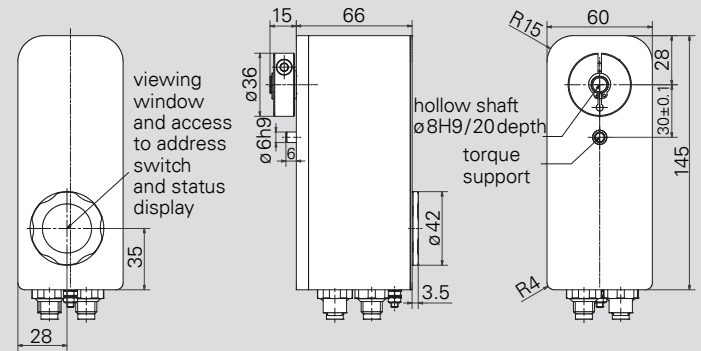

PSW 30_-8-V (with solid shaft)

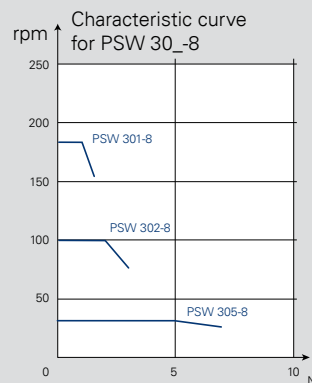
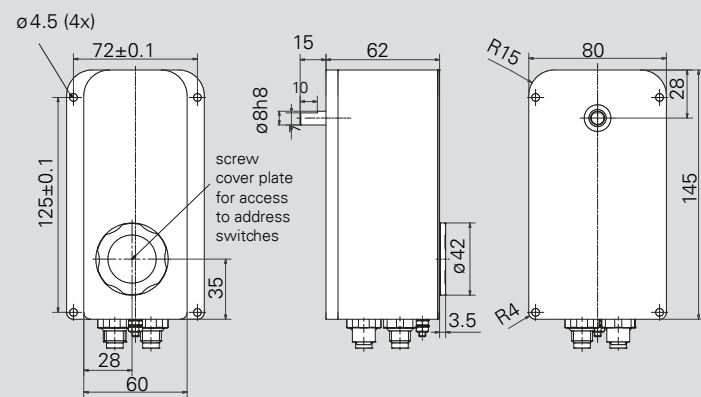

For details of the connections please see also p. 47 and the instruction manual.



PSW 30_/32_-14 (with hollow shaft)

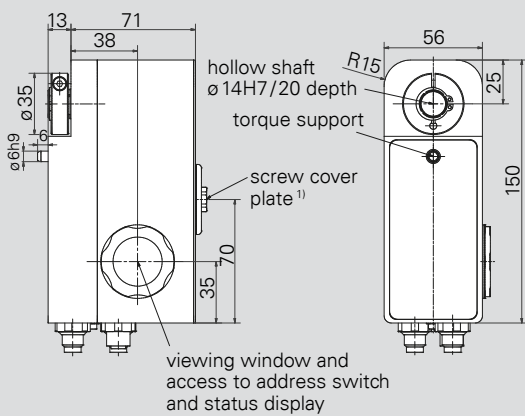

PSW 30_/32_-14-V (with solid shaft)

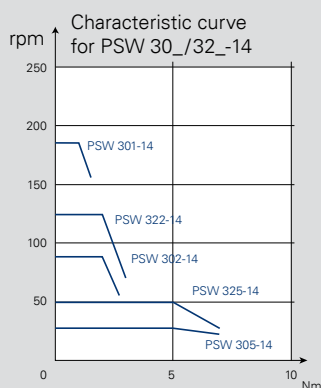
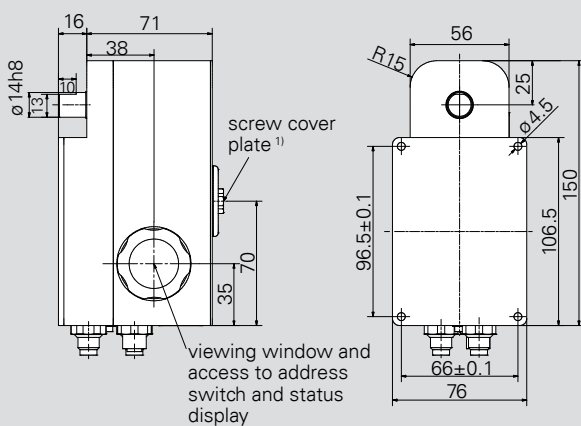

For details of the connections please see also p. 47 and the instruction manual.

¹⁾ over a rotating manual adjustment shaft SW6/8 depth hex

Product	Nominal torque	Self-holding torque	Nominal rated speed
PSW 301-14	1 Nm	0.5 Nm	180 rpm
PSW 302-14	2 Nm	1 Nm	90 rpm
PSW 305-14	5 Nm	2.5 Nm	35 rpm
PSW 322-14	2 Nm	1 Nm	125 rpm
PSW 325-14	5 Nm	2.5 Nm	50 rpm

Data interfaces

CANopen, PROFIBUS DP, DeviceNet, Modbus RTU, Sercos, EtherCAT, PROFINET, EtherNet/IP, POWERLINK, IO-Link

Start-up duration	20 % (basis time 600 s) at nominal torque
Mode of operation	S3
Supply voltage	24 VDC ± 10 % galvanically separated between control and motor and bus
Nominal current	PSW 30_: 2.4 A, PSW 32_: 3.1 A
Power consumption (control unit)	0.1 A
Positioning accuracy	0.9° absolute measurement of position taken directly at the output shaft
Positioning range	250 rotations not subject to mechanical limits
Shock resistance	50g 11 ms in accordance with IEC/DIN EN 60068-2-27
Vibration resistance	10..55 Hz 1.5 mm/ 55..1 000 Hz 10g/ 10..2 000 Hz 5g in accordance with IEC/DIN EN 60068-2-6
Output shaft	14 mm solid shaft or 14 mm hollow shaft with adjustable collar
Maximum axial force	20 N
Maximum radial force	40 N
Ambient temperature	0..45 °C
Storage temperature	-10..70 °C
Protection class	IP68 at standstill ²⁾ , IP66 during rotation (tested with water) ²⁾
Material	stainless steel
Weight	1 200g
Certificates	CE, optional: NRTL (UL, CSA, ANSI)

²⁾ welded V2A housing, output shaft sealed with quad-ring

The order key and accessories can be found on p. 18/19.



Product	Nominal torque	Self-holding torque	Nominal rated speed
PSW 311-8	1 Nm	0.5 Nm	180 rpm
PSW 312-8	2 Nm	1 Nm	100 rpm
PSW 315-8	5 Nm	2.5 Nm	35 rpm

Data interfaces
CANopen, PROFIBUS DP, DeviceNet, Modbus RTU, Sercos, EtherCAT, PROFINET, EtherNet/IP, POWERLINK, IO-Link

Start-up duration	20 % (basis time 600 s) at nominal torque
Mode of operation	S3
Supply voltage	24 VDC ± 10 % galvanically separated between control and motor and bus
Nominal current	2.2 A
Power consumption (control unit)	0.1 A
Positioning accuracy absolute measurement of position taken directly at the output shaft	0.9°
Positioning range	250 rotations not subject to mechanical limits
Shock resistance in accordance with IEC/DIN EN 60068-2-27	50 g 11 ms
Vibration resistance in accordance with IEC/DIN EN 60068-2-6	10 .. 55 Hz 1.5 mm / 55 .. 1 000 Hz 10 g / 10 .. 2 000 Hz 5 g
Output shaft	8 mm solid shaft or 8 mm hollow shaft with adjustable collar
Maximum axial force	20 N
Maximum radial force	40 N
Ambient temperature	0 .. 45 °C
Storage temperature	-10 .. 70 °C
Protection class	IP68 at standstill ¹⁾ , IP66 during rotation (tested with water) ¹⁾
Material	stainless steel
Weight	700 g
Certificates	CE, optional: NRTL (UL, CSA, ANSI)

¹⁾ welded V2A housing, output shaft sealed with quad-ring

The order key and accessories can be found on p. 18 / 19.

PSW 31_-8 (with hollow shaft)

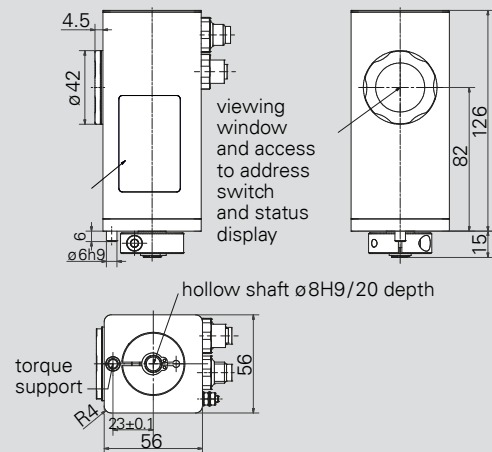

PSW 31_-8-V (with solid shaft)

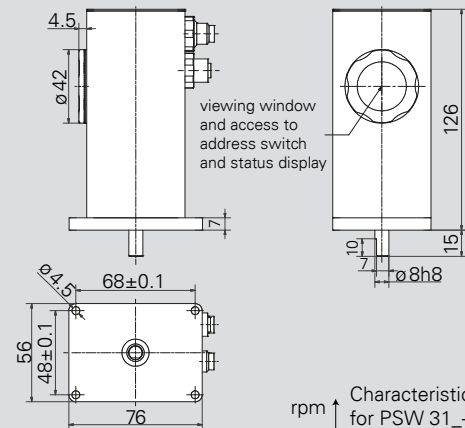

For details of the connections please see also p. 47 and the instruction manual.

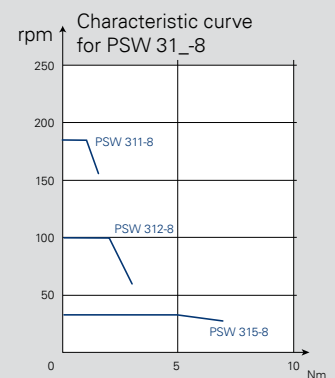



PSW 31_/33_-14 (with hollow shaft)

viewing window and access to address switch and status display cover, manual adjustment beneath

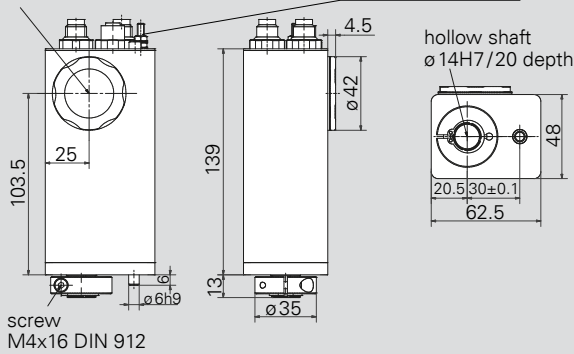

PSW 31_/33_-14-V (with solid shaft)

viewing window and access to address switch and status display cover, manual adjustment beneath

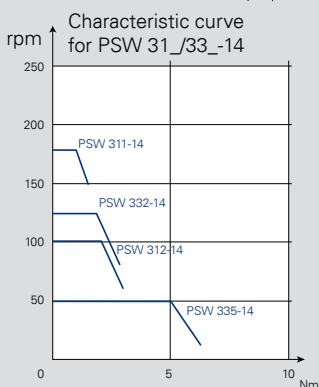
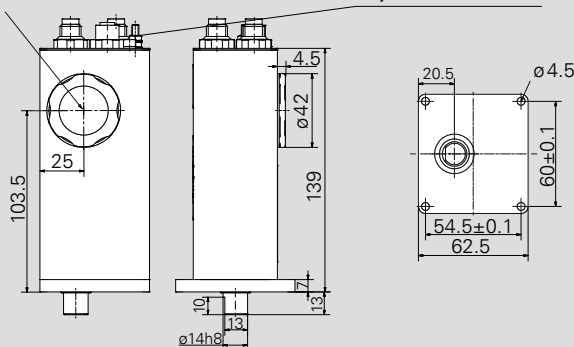

For details of the connections please see also p. 47 and the instruction manual.

Product	Nominal torque	Self-holding torque	Nominal rated speed
PSW 311-14	1 Nm	0.5 Nm	180 rpm
PSW 312-14	2 Nm	1 Nm	100 rpm
PSW 332-14	2 Nm	1 Nm	125 rpm
PSW 335-14	5 Nm	2.5 Nm	50 rpm

Data interfaces

CANopen, PROFIBUS DP, DeviceNet, Modbus RTU, Sercos, EtherCAT, PROFINET, EtherNet/IP, POWERLINK, IO-Link

Start-up duration	20 % (basis time 600 s) at nominal torque
Mode of operation	S3
Supply voltage	24 VDC ± 10 % galvanically separated between control and motor and bus
Nominal current	PSW 31_: 2.4 A, PSW 33_: 3.1 A
Power consumption (control unit)	0.1 A
Positioning accuracy absolute measurement of position taken directly at the output shaft	0.9°
Positioning range	250 rotations not subject to mechanical limits
Shock resistance in accordance with IEC/DIN EN 60068-2-7	50 g 11 ms
Vibration resistance in accordance with IEC/DIN EN 60068-2-6	10..55 Hz 1.5 mm/ 55..1 000 Hz 10 g/ 10..2 000 Hz 5 g
Output shaft	14 mm solid shaft or 14 mm hollow shaft with adjustable collar
Maximum axial force	20 N
Maximum radial force	40 N
Ambient temperature	0..45 °C
Storage temperature	-10..70 °C
Protection class	IP68 at standstill ¹⁾ , IP66 during rotation (tested with water) ¹⁾
Material	stainless steel
Weight	700 g
Certificates	CE, optional: NRTL (UL, CSA, ANSI)

¹⁾ Welded V2A housing, output shaft sealed with quad-ring

The order key and accessories can be found on p. 18 / 19.

POSITIONING SYSTEMS 2 SERIES

PSE 21_/23_-8



Start-up duration	50 % (basis time 300 s)
Supply voltage	24 VDC \pm 10 %
Nominal current	0.7 A
Power consumption (motor control unit)	0.1 A
Positioning accuracy measurement of position taken directly at the output shaft	0.9°
Positioning range quasi absolute measurement system: absolute measurement system:	unlimited 64 rotations
Shock resistance in accordance with IEC/DIN EN 60068-2-27	50g 11 ms
Vibration resistance in accordance with IEC/DIN EN 60068-2-6	10..55 Hz 1.5 mm / 55..1 000 Hz 10 g / 10..2 000 Hz 5 g
Output shaft	8 mm solid shaft or 8 mm hollow shaft with adjustable collar
Maximum axial force	20 N
Maximum radial force	40 N
Connections	electrical connections via terminal bar (max. 1.5 mm ²)
Ambient temperature	0..45°C
Storage temperature	-10..70°C
Protection class	IP54
Weight	500 g
Certificates	CE

PSE 21_/23_-8 with solid shaft

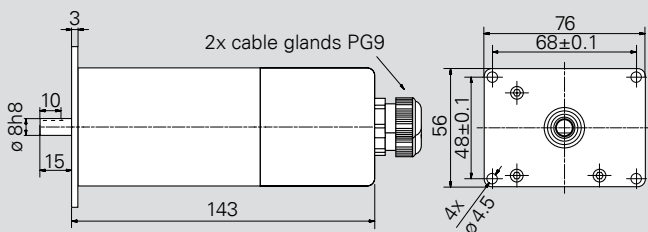

PSE 21_/23_-8 with hollow shaft

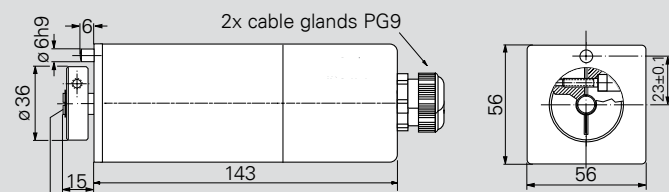

hollow shaft \varnothing 8H9/20 depth

For details of the connections please see also p. 47 and the instruction manual.

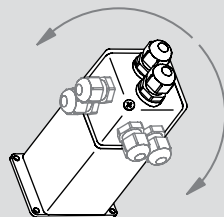

The cable gland can be moved into different positions by turning the cover by 90°.

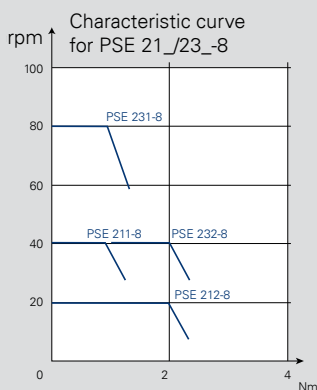

Functional block diagram PSE 21_/23_-8

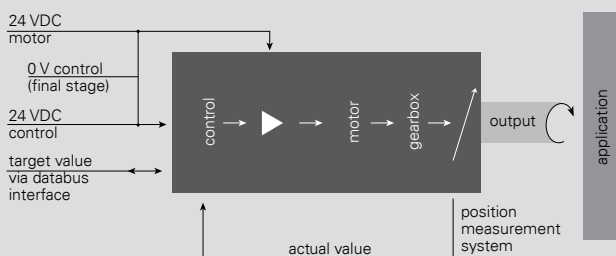

Nominal torque	Nominal rated speed	A
1 Nm	40 rpm	211-8
2 Nm	20 rpm	212-8
1 Nm	80 rpm	231-8
2 Nm	40 rpm	232-8

Data interfaces	B
CANopen	CA
DeviceNet	DN
Modbus RTU	MB

Address switches / baud rate switches	C
without address/baud rate switches ¹⁾	O
with address/baud rate switches adjustable baud rate, 500 kBaud, 250 kBaud, 125 kBaud	A

¹⁾ only for CANopen / DeviceNet

Output shaft	D
8 mm solid shaft	W
8 mm hollow shaft with adjustable collar	H

Measurement system	E
quasi absolute measurement system	0
absolute measurement system, 64 rotations	1

Order code	A	B	C	D	E
PSE	-	-	-	-	-

HIPERDRIVE POSITIONING SYSTEMS

HDA 70

HDA Hub

PSE 441

HIPERDRIVE POSITIONING SYSTEMS

The HIPERDRIVE series facilitates both direct wiring and indirect wiring via a Hub (see p. 8 +9)

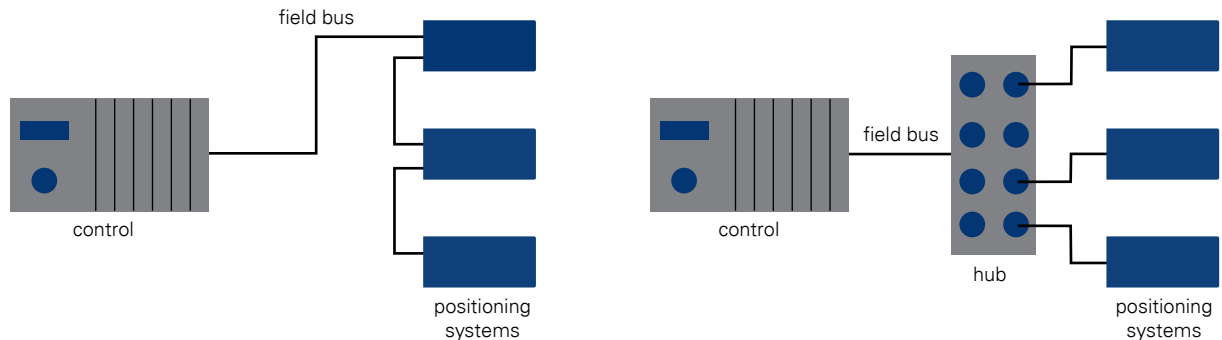

A direct wiring (adapter) → see p. 40

B indirect wiring via Hub → see p. 41

ACCESSORIES FOR HIPERDRIVE HDA 70 AND PSE 441

HDA 70 with bus communication (Industrial Ethernet ¹⁾ and PROFIBUS DP)				
A	Bus cable for Industrial Ethernet with an M12 connector (D-cod.) 10 m: Order no. 9508.0045 20 m: Order no. 9508.0046		Power supply cable with a 7/8" connector socket 10 m: Order no. 9508.0043 20 m: Order no. 9508.0044	
	Connector set for EtherCAT, PROFINET, EtherNet/IP: 7/8" power supply connector + 2 x databus connector Order no. 9508.0050			
	Bus cable for PROFIBUS DP with an M12 connector socket (B-cod.) 10 m: Order no. 9508.0011 25 m: Order no. 9508.0017		Connector for PROFIBUS DP M12 connector socket (B-cod.) Order no. 9508.0027	
	Connector set for PROFIBUS DP: 7/8" power supply connector + databus connector and socket Order no. 9508.0034		Connector for PROFIBUS DP M12 connector (B-cod.) with terminating resistors: Order no. 9508.0013	
HDA 70 with RS485 (for indirect cabling via Hub)				
B	Simple flange adapter with cable: 1 m: Order no. 9508.0038 2 m: Order no. 9508.0033 5 m: Order no. 9508.0019 10 m: Order no. 9508.0010 15 m: Order no. 9508.0008		Connecting cable (with crimp contacts at one end) without adapter 2.5 m: Order no. 9508.0030	
			Adapter without cable Order no. 9508.0009	
PSE 441 with RS485				
	Power supply and bus cable with an M12 connector socket (A-cod.) 10 m: Order no. 9508.0022 15 m: Order no. 9508.0035		Connector M12 connector socket (A-cod.) for PSE 441 master Order no. 9601.0144	
			Connector M12 connector (A-cod.) for PSE 441 slave drive Order no. 9601.0152	

¹⁾ EtherCAT, PROFINET, EtherNet/IP

HIPERDRIVE HDA 70

for direct wiring (with adapter)

Start-up duration	30 % (basis time 300 s)
Mode of operation	S3
Supply voltage	24 VDC ± 15 %
Nominal current	4.8 A
Positioning accuracy	± 1°
Positioning range	32000 rotations not subject to mechanical limits
Shock resistance in accordance with IEC/DIN EN 60068-2-27	10 g 30 ms
Vibration resistance in accordance with IEC/DIN EN 60068-2-6	10 .. 150 Hz 10 g
Insulation class	B (120°)
Maximum axial force	axial shaft: 150 N radial shaft: 165 N
Maximum radial force	axial shaft: 200 N radial shaft: 440 N
Ambient temperature	max. 45°C
Storage temperature	-25 .. 75°C
Protection class	IP 65
Weight	axial 2.8 kg/radial 3.2 kg
Certificates	CE

Product	Nominal torque	Self-holding torque	Nominal rated speed
HDA 70	15 Nm	25 Nm	27 rpm

Data interfaces	A
PROFIBUS DP	DP
EtherCAT	EC
PROFINET	PN
EtherNet/IP	EI
RS 485 ¹⁾	I

¹⁾ for control via HUB

Shaft position	B
axial, without bevel gear	L
radial, with bevel gear i = 1, position type 1	1
radial, with bevel gear i = 1, position type 2	2
radial, with bevel gear i = 1, position type 3	3
radial, with bevel gear i = 1, position type 4	4

Connections	C
Cable gland (for DP)	B
Connector, 6-pin (RS 485 without Hub)	E
Connector, 6-pin (RS 485 with Hub)	H
Cable gland for 24 VDC, 2 x M12 female connector for IE-bus in/out	S
Male connector (7/8") for 24 VDC, 2 x M12 female connector for IE-bus in/out	T

Output shaft design	D
10 mm solid shaft with feather key (radial/axial)	S
10 mm hollow shaft (only radial, with bevel gear)	H10
12 mm hollow shaft (only radial, with bevel gear)	H12

Order code	A	B	C	D
HDA 70				



HDA 70 with adapter (axial, without bevel gear)

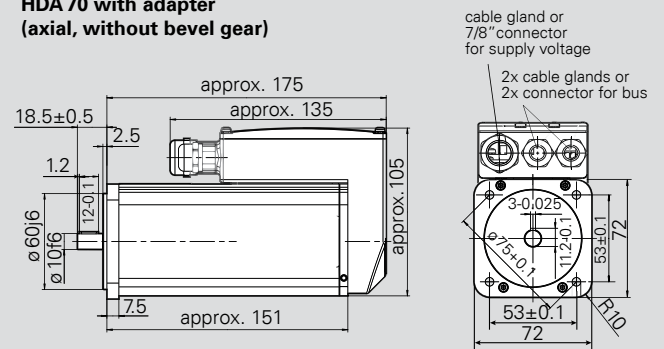

HDA 70 with adapter (radial, with bevel gear, i = 1)

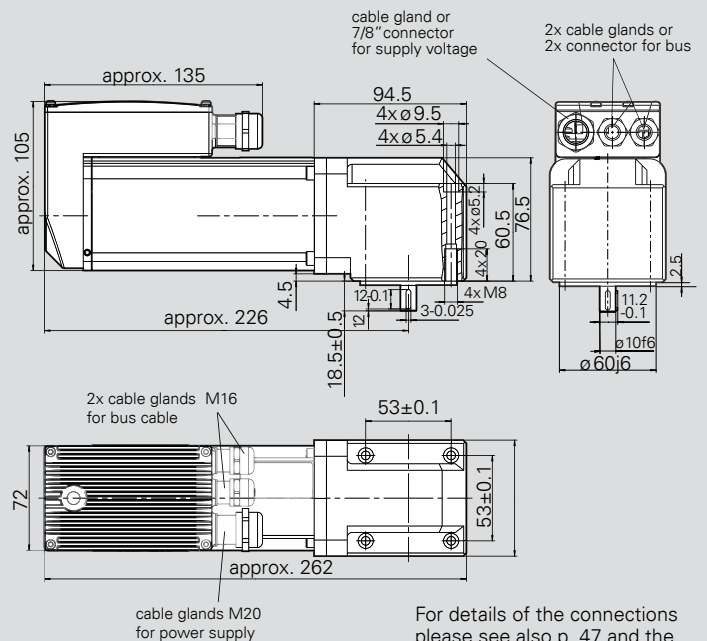

For details of the connections please see also p. 47 and the instruction manual.

Shaft position

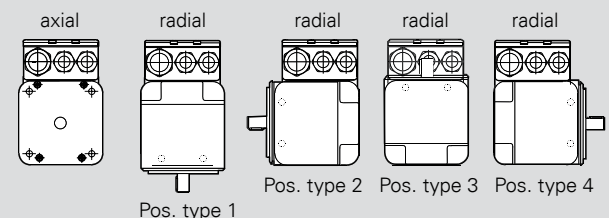

HIPERDRIVE HDA 70

for wiring via HUB



Supply voltage	24 VDC ± 15 %
Power consumption (control unit)	300 mA
Shock resistance in accordance with IEC/DIN EN 60068-2-27	8g 20 ms
Vibration resistance in accordance with IEC/DIN EN 60068-2-6	10..500 Hz 10 mm
Certificates	CE
Motor connection cables, operating voltage for data X-D1..8	6 x adjustable collar max. cross-section of conductor 1.5 mm ²
Operating voltage connection, motors X-A+, X-A-, equipotential bonding	cable lug M6
Bus terminating resistor	via external terminal resistance
Bus connection	M12, 5-pin Type B (PROFIBUS DP) 2x M12, 5-pin Type D (Ethernet-based buses) 2x
Address range adjustable via switches	0..125 (0..99 for Ethernet-based buses)
Housing	die-cast zinc
Ambient temperature	0..45 °C
Storage temperature	-25..75 °C
Protection class with IEC 60529	IP65
Weight	4.5 kg

HDA 70 (axial, without bevel gear)

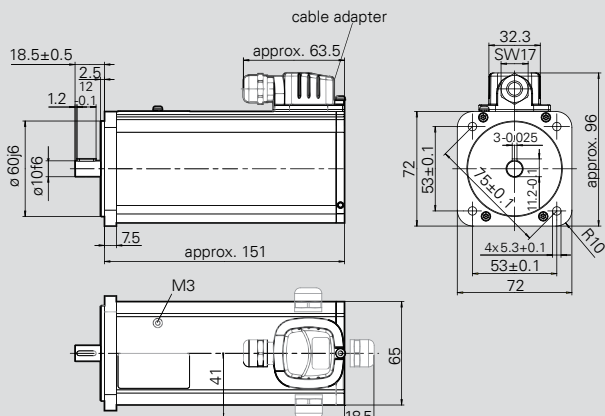

HDA 70 (radial, with bevel gear, i = 1)

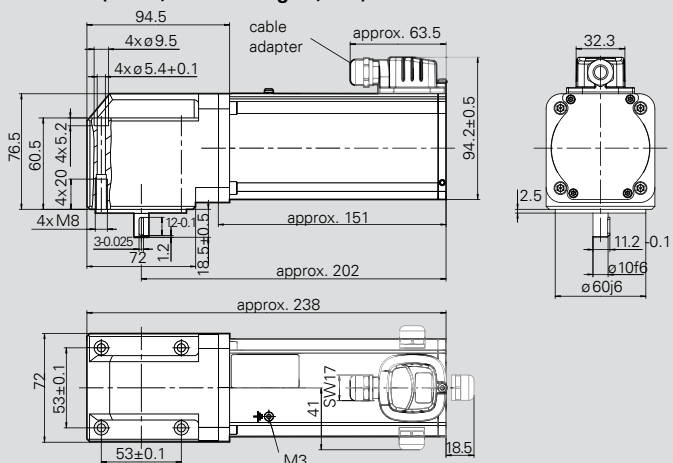

For details of the connections please see also p. 47 and the instruction manual.

Shaft position

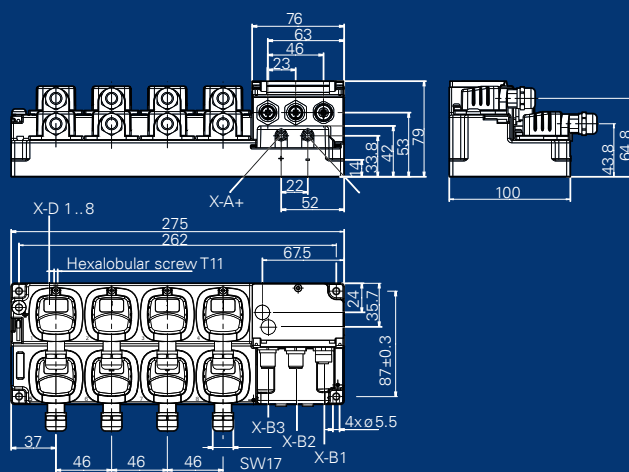
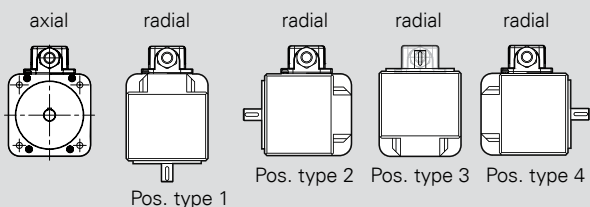

Data interfaces ¹⁾	A
PROFIBUS DP	DP
EtherCAT	EC
PROFINET	PN
EtherNet/IP	EI

¹⁾ via RS 485 between HUB and HDA/PSE 441

Order code	A
Hub	-

Start-up duration	30 % (basis time 300 s)
Mode of operation	S3
Supply voltage	24 VDC \pm 10 %
Nominal current	0.8 A
Positioning accuracy measurement of position taken directly at the output shaft	\pm 2.5°
Positioning range	250 rotations not subject to mechanical limits
Shock resistance in accordance with IEC/DIN EN 60068-2-27	30 g 11 ms
Vibration resistance in accordance with IEC/DIN EN 60068-2-6	10 .. 150 Hz 10g
Output shaft	10 mm solid shaft with feather key
Maximum axial force	20 N
Maximum radial force	50 N
Ambient temperature	10 .. 45°C
Storage temperature	-10 .. 70°C
Protection class	IP 65
Housing	plastic
Weight	600 g
Certificates	CE

Nominal torque	Peak torque	A
1.5 Nm	2.5 Nm	441
@ 40 rpm	@ 10 rpm	

Data interfaces	B
RS 485	I

Connections	C
Standard for connection to the Hub (one shared connector for the power supply and bus)	S
Standard + 2 nd connection for further device, power supply looped through, bus: daisy chain RS 485 ¹⁾	B

¹⁾ A "daisy chain" is only possible if the control is used as the bus master, not possible using the Hub.

Order code	A	B	C
PSE	441	I	

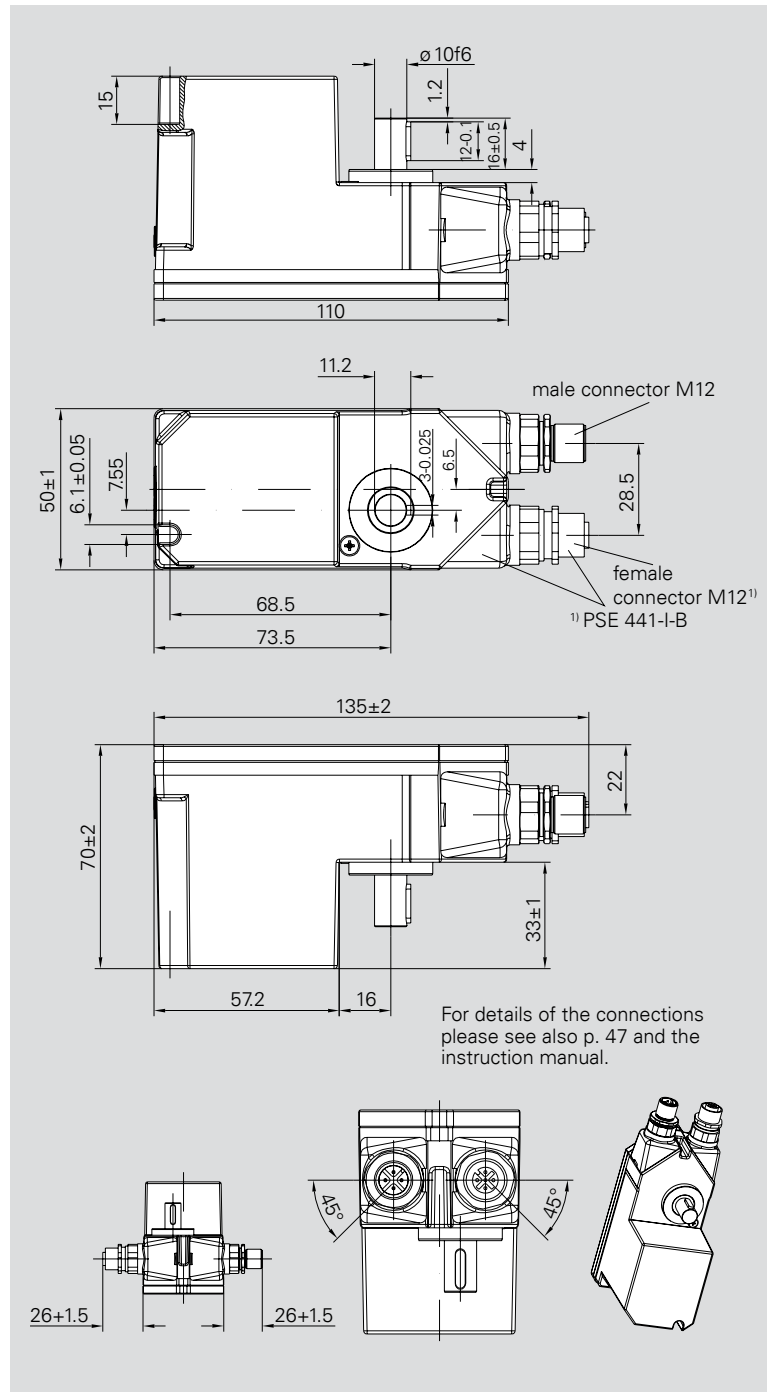
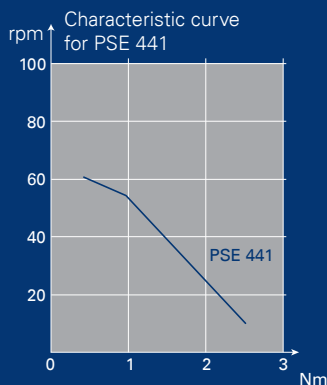

ANALOGUE POSITIONING SYSTEMS

PSE 100/200

PSE 272

Nominal current	PSE 100: 0.2A PSE 200: 1A
No-load current	0.2 A
Positioning resolution	0.5 % of positioning range
Positioning accuracy	2 % of positioning range
Positioning range	PSE 100: max. 20 rotations PSE 200: max. 50 rotations
Shock resistance in accordance with IEC/DIN EN 60068-2-27	50 g 11 ms
Vibration resistance in accordance with IEC/DIN EN 60068-2-6	10..55 Hz 1.5 mm / 55..1 000 Hz 10 g / 10..2 000 Hz 5 g
Output shaft	12 mm solid shaft (with flattening)
Maximum axial force	20 N
Maximum radial force	30 N
Ambient temperature	0..50 °C
Storage temperature	-10..70 °C
Protection class	IP 55
Weight	900 g
Certificates	CE

Product	Nominal torque	Nominal rated speed	A
PSE 100	2.5 Nm	2 rpm	100/1
	5 Nm	1 rpm	100/2
	10 Nm	0.5 rpm	100/3
	10 Nm	0.25 rpm	100/4
PSE 200	1 Nm	30 rpm	200/1
	5 Nm	5 rpm	200/2
	10 Nm	2 rpm	200/3
	10 Nm	1 rpm	200/4
	10 Nm	0.5 rpm	200/5
	10 Nm	0.25 rpm	200/6

Default analog target value	B
0..10 VDC ($R_L > 2 \text{ k}\Omega$)	A
0..20 mA ($R_L < 500 \Omega$)	B
4..20 mA ($R_L < 500 \Omega$)	C

Supply voltage	C
PSE 200	24 VDC (+20/-15 %)
PSE 100	24 VAC (+6/-15 % 50 Hz)
	115 VAC (+6/-15 % 50 Hz)
	230 VAC (+6/-15 % 50 Hz)

positioning range	D
0..360°	— °
max. 50 (PSE 200)/20 rotations (PSE 100)	— U

Output signal actual value	E
0..10 V	A
0..20 mA	B
4..20 mA	C

Rotational direction	F
left	li
right	re

Order code	A	B	C	D	E	F
PSE	-	-	-	-	-	-

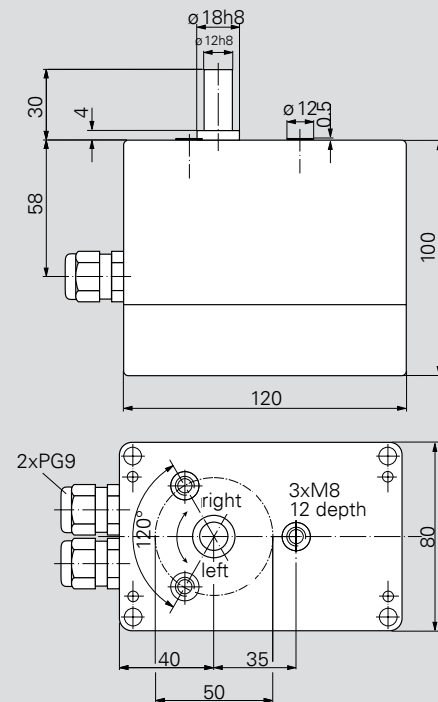

Functional block diagram PSE 100

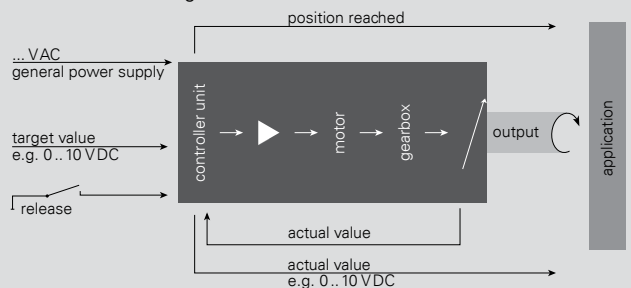

Functional block diagram PSE 200

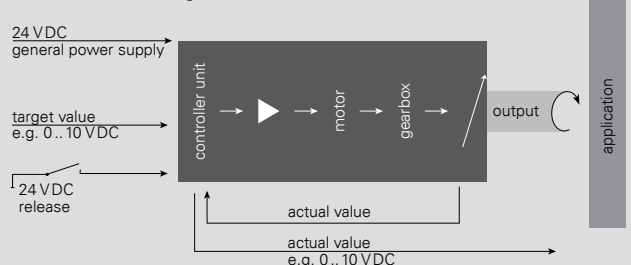

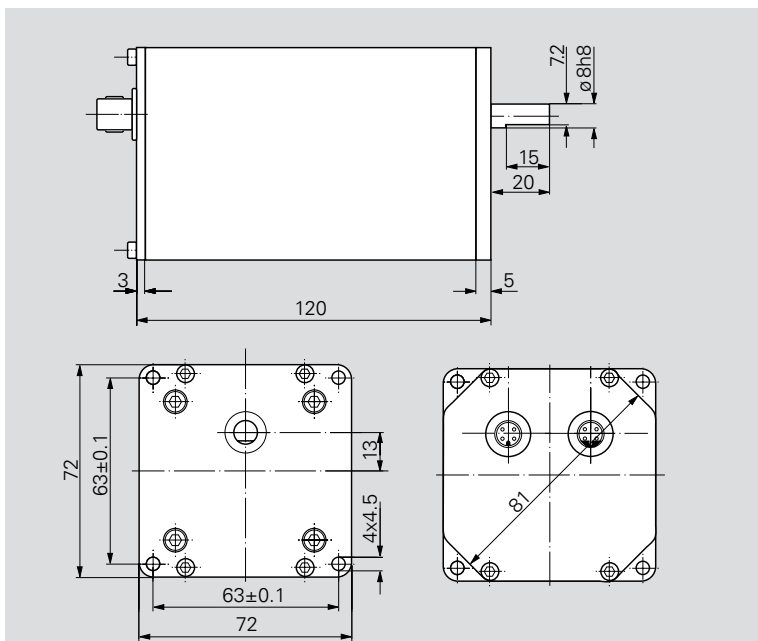

Start-up duration	100 %
Supply voltage	24 VDC (+ 20/- 15 %)
Nominal current	0.5 A
No-load current	0.2 A
Positioning resolution	0.5 % of positioning range
Positioning accuracy	2 % of positioning range
Positioning range	max. 15 rotations
Shock resistance in accordance with IEC/DIN EN 60068-2-27	50 g 11 ms
Vibration resistance in accordance with IEC/DIN EN 60068-2-6	10..55 Hz 1.5 mm / 55..1 000 Hz 10 g / 10..2 000 Hz 5 g
Output shaft	8 mm solid shaft
Maximum axial force	20 N
Maximum radial force	30 N
Ambient temperature	0..50 °C
Storage temperature	-10..70 °C
Protection class	IP65
Weight	800 g
Certificates	CE

Nominal torque	Nominal rated speed	A
1 Nm	60 rpm	272/1
2 Nm	30 rpm	272/2
4 Nm	15 rpm	272/3
5 Nm	7.5 rpm	272/4

Default analog target value	B
0..10 VDC ($R_L > 2 \text{ k}\Omega$)	A
0..20 mA ($R_L < 500 \Omega$)	B
4..20 mA ($R_L < 500 \Omega$)	C

Positioning range ¹⁾	C
max. 15 rotations	

¹⁾ Value in rotations, max. 15 possible. For < 1 rotation, conversion of the angle. Example: $270^\circ = 0.75$ rotations.

Order code	A	B	C	D
PSE	-	-	-	-

Accessories

Mating connector Order no. 9601.0048
(A encoded socket and one B encoded socket, 4-pole)

Functional block diagram PSE 272

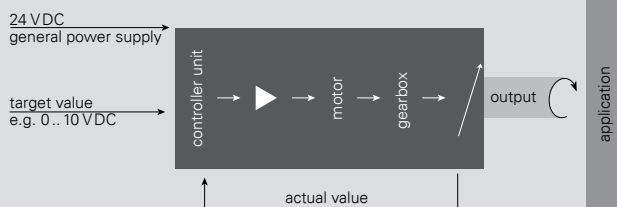

FOCUS YOUR THINKING ON INDUSTRY 4.0

Advanced production: Industry 4.0

Highly flexible and smooth design of all production processes – that is a key point of the Industry 4.0 concept. One aspect is networking things involved in production together: machines, equipment, tools, storage systems and also the resulting products.

The term **Internet of Things** describes networking via information technology. A networked factory is called a **smart factory**. The things involved in smart factory production are not just physical. They are reflected in the Internet of Things. The reflection is called a **virtual image** and is stored there with a lot of data. If something involved in production is represented by a virtual image and networked with others, it is called a **cyber-physical system**. It interacts with other systems.

Positioning systems as cyber-physical systems

Our positioning systems have all the components to constitute a self-contained cyber-physical system:

- Actuators on the drive: gearbox, motor, motor control
- Absolute encoders: positioning sensor
- Embedded system: decentralised on-board intelligence

The positioning system moves independently to target positions and reacts to deviations. It differentiates between contamination or blockage of its axis and acts: accelerating if the spindle is contaminated and braking if there are blockages caused by obstacles.

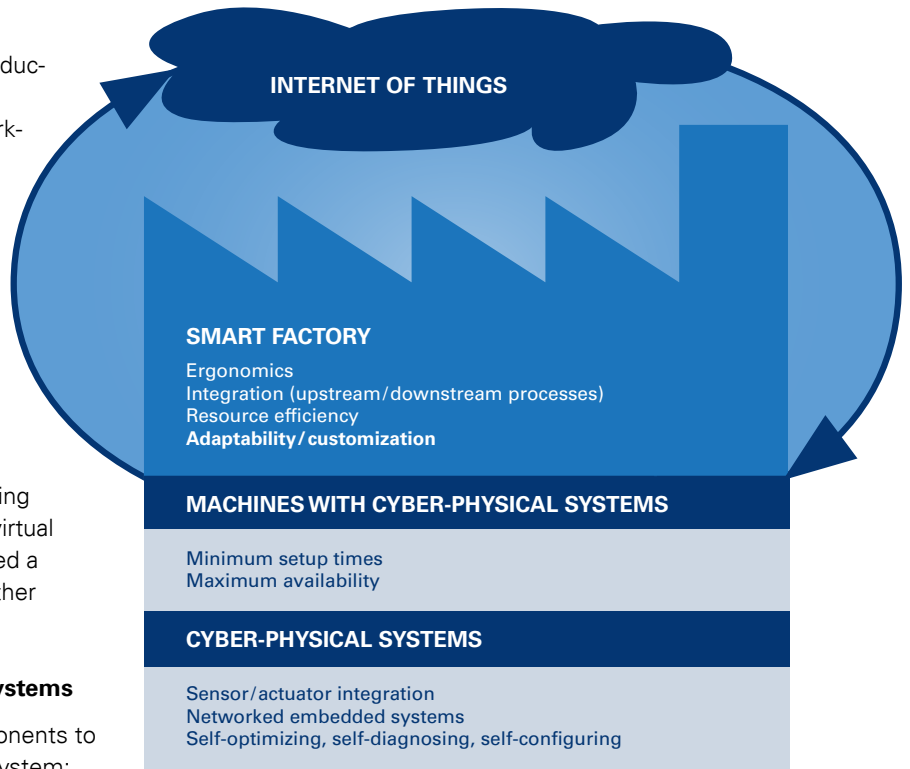

The system positions optimally and independently, and only puts a minimal load on the machine control. Because the control unit only gives the drive command.

Positioning systems assist with factory automation for the purpose of Industry 4.0: They are optimally integrated into flexible machine processes and offer monitoring functions.

WATCH OUR FILMS AS WELL



A number of short films are available on our website. These give you a quick overview and also a few insights into some of the most important details.

www.halstrup-walcher.com

- ▶ Navigation: "Applications"
- ▶ "Positioning systems"

Find films on the following topics:

- **Mechanical engineering** approaches to automation (under "Machine concepts with format changeover")
- **Advantages of automated format changeover** from the viewpoint of the machinery user e.g. in furniture manufacturing (under "Format changeover – wood-processing")
- **Automation in bottle filling**: Precision, preventive maintenance and bus communication flexibility (under "Format changeover – bottling plants")

OVERVIEW: BUS COMMUNICATION

Bus	Topology	max. number	Terminating resistance	Connection ¹⁾	Jog keys	Addressing	Bus length @ Baud rate ...	Description of device ²⁾	
PSE 2_									
CANopen	series (all slaves connected in parallel)	126	2 x 120 Ω not integrated in the device/ attach to cable ends	spring clamp terminals (motor power supply (M) + control power supply (S) + data (D)) M12 (M+S) and M12 (D) possible	without	via switch and bus	250 kBaud: 250 m 500 kBaud: 100 m	EDS	
DeviceNet		63							
Modbus RTU		247	2 x 390 Ω + 1 x 220 Ω integrated in the device, activation possible				9600 Baud: 500 m 38400 Baud: 50 m	-	
PSE/PSS/PSW 30_, 31_, 32_, 33_									
CANopen	series (all slaves connected in parallel)	126	2 x 120 Ω not integrated in the device/ attach to cable ends	M12 - A (M + S), 2 x M12 - B (D) optional: Sub - D9 (D), Sub - D9 (M+S), M12 - B (M+S), 2 x M12 - A (D) ⁴⁾	M8 connector ⁵⁾	via switch and bus	250 kBaud: 250 m 500 kBaud: 100 m	EDS	
DeviceNet		63							M12 - B (M), 2 x M12 - A (S + D) ⁴⁾
PROFIBUS DP		32 126 (R) ³⁾	2 x 390 Ω + 1 x 220 Ω integrated in the device, activation possible	M12 - A (M + S), 2 x M12 - B (D) optional: Sub - D9 (D) ⁴⁾		via switch (and bus)	1.5 MBaud: 200 m 12 MBaud: 100 m	GSD	
Modbus RTU		247	2 x 390 Ω + 1 x 220 Ω integrated in the device, activation possible	M12-A (M + S), 2 x M12-B (D) ⁴⁾		via switch and bus	9600 Baud: 500 m 38400 Baud: 50 m	-	
IO-Link	star via hub (point to point)	limited by the bus master	not required	M12-A (M+S+D)	without	not required	38400 Baud: 20 m	IOOD	
Sercos	series, ring or star via hub (point to point)	511		M12-A (M+S), 2 x M12-D (D) or M12-Y (M+S+D)	M8 connector ⁵⁾	via switch and bus	100 MBaud: 100 m	SDDML	
EtherCAT		65535						ESI	
PROFINET		limited by PLC						GSDML	
EtherNet/IP								EDS	
POWER-LINK		239						XDD	
PSE 34_									
CANopen	series (all slaves parallel)	126	2 x 120 Ω not integrated in the device/ attach to cable ends	HAN4A (M+S), 2 x M12-B (D), optional: 2 x M12-A (D)	without	via switch and bus	250 kBaud: 250 m 500 kBaud: 100 m	EDS	
PROFIBUS DP		32 126 (R) ³⁾							2 x 390 Ω + 1 x 220 Ω integrated in the device, activation possible
Sercos	series, ring (point to point)	511	not required	M12-A (M+S), 2 x M12-D (D)	M8 connector	via switch and bus	100 MBaud: 100 m	SDDML	
EtherCAT		65535						ESI	
PROFINET		limited by PLC						GSDML	
EtherNet/IP								EDS	
POWER-LINK		239						XDD	
HIPERDRIVE Hub									
PROFIBUS DP	series (all slaves parallel)	32 126 (R) ³⁾	2 x 390 Ω + 1 x 220 Ω not integrated in the device/ attach to cable ends	cable lug (motor power supply), M12-A (S), 2 x M12-B (D)	can be accessed after opening the housing cover	via switch	1.5 MBaud: 200 m 12 MBaud: 100 m	GSD	
EtherCAT	series, ring (point to point)	65535							not required
PROFINET		limited by PLC		GSDML					
EtherNet/IP				EDS					
HIPERDRIVE HDA 70									
PROFIBUS DP	series (all slaves parallel)	32 126 (R) ³⁾	2 x 390 Ω + 1 x 220 Ω integrated in the device, activation possible	Screw collars (M+S+D), Screw collars (M+S), 2 x M12 - B (D), 7/8" (M+S), 2 x M12 - B (D)	on the exterior of the device	via switch	1.5 MBaud: 200 m 12 MBaud: 100 m	GSD	
EtherCAT	series, ring (point to point)	65535							not required
PROFINET		limited by PLC		GSDML					
EtherNet/IP				EDS					
RS485	series	254	2 x 1 kΩ + 1 x 130 Ω not integrated in the device/attach to cable ends/optionally available in the device	Molex series 5557/69 (M+S+D)	only possible via bus	9600 Baud: 500 m 38400 Baud: 50 m	-		
PSE441									
RS485	series (point to point)	254	not required	1..2 x M12-A (M+S+D)	on the exterior of the device	via bus	9600 Baud: 500 m 38400 Baud: 50 m	-	

¹⁾ M (motor power supply), S (control power supply), D (data)

²⁾ description files available to download at www.halstrup-walcher.de/en/software

³⁾ with repeater (R)

⁴⁾ as connector solution/plug-in solution M12-Y (M+S+D) on request

⁵⁾ not for PSW or IO-Link

halstrup-walcher GmbH
Stegener Str. 10
79199 Kirchzarten
Germany

Tel. + 49 (0) 76 61 39 63-0
Fax + 49 (0) 76 61 39 63-99
info@halstrup-walcher.de
www.halstrup-walcher.com

**Austria / Hungary /
Poland / Slovenia**

Kwapil & Co. GmbH
Kammelmweg 9
1210 Wien
Austria
Tel. + 43 (0) 1 278 85 85
Fax + 43 (0) 1 278 85 86
verkauf@kwapil.com
www.kwapil.com

China

Shanghai Yu Ting
Scientific Co., LTD
Room 602, No. 45, Lane 1661
Jialour Rd., Jiading District,
Shanghai City, PRC
Tel. + 86 21 6915 3366
Fax + 86 21 6915 3939
ch-sys@ch-sys.net
www.ch-sys.net

Great Britain / Ireland

HMK LTD
Automation and Drives
Congleton, Cheshire
CW12 1QJ
England
Tel. +44 1260 279411
Fax +44 1260 281022
enquiries@hmkdirect.com
www.hmkdirect.com

India

Parshvi Technology
Shop No : 10, Block A,
Ground Floor
Pushp Business Campus,
S P Ring Road, Vastral
AHMEDABAD 382418
GUJARAT
Tel. +91 8128705212
ram@parshvitechnology.com
www.parshvitechnology.com

Italy

halstrup-walcher S.r.l.
Viale Colleoni, 15
(Palazzo Orione, 2)
20864 - Agrate Brianza (MB)
Tel. +39 039 9630 880
Fax +39 039 9630 883
info@halstrup-walcher.it
www.halstrup-walcher.it

Netherlands

Elmekanic B.V.
Spelleweg 3
7475 GV Markelo
Tel. + 31 (0) 547 367 357
Fax + 31 (0) 547 367 356
info@elmekanic.nl
www.elmekanic.nl

Slovakia / Czech Republic

Kwapil & Co. GmbH
Hlavní 1054/131
624 00 Brno
Czech Republic
Tel. +420 (0) 541 211 538
Fax +420 (0) 541 217 467
sales@kwapil.com
www.kwapil.cz

Spain

INTRA AUTOMATION S. L.
PT.Paterna, R. de Auguste I
Louis Lumiere, n° 45, Nave 3
46980 Paterna, Valencia
Tel. +34 963 961 008
Fax +34 963 961 018
info@intraautomationsl.com
www.intraautomationsl.com

Switzerland

Trelco AG
Gewerbstrasse 10
5037 Muhen
Tel. + 41 (0) 62 737 62 62
Fax + 41 (0) 62 737 62 70
trelco@trelco.ch
www.trelco.ch

Taiwan

Chih Horng Scientific Co., Ltd.
6F., No.69-5, Sec. 2,
Zhongzheng E. Rd.,
Tamsui Dist.,
New Taipei City 251
Tel. +886 (02) 2808 0169
Fax +886 (02) 2808 0176
chih.mail@msa.hinet.net
www.ch-sys.com

Turkey

CAGDAS Automation
& Engineering Co. Ltd.
Kizilay cad. 28006 sok No: 5
01010 Seyhan/Adana
Tel. + 90 (0) 322 359 81 85
Fax + 90 (0) 322 359 36 39
cagdas@cagdasltd.com.tr
www.cagdasltd.com.tr

USA

Intelligent Measurement Solutions LLC
3635 Dawes
49508 Grand Rapids, MI
Tel. +1 (616) 608 79 19
Mobil +1 (734) 637-1596
Fax +1 (616) 608 79 54
darrell@i-m-solutions.net
www.h-wusa.com