



Induction Melting, Heating, Holding & Pouring Systems

INDUCTOTHERM: GIVING YOU THE EDGE

About Inductotherm

Inductotherm is the world leader in induction technology. We build melting, holding, heating and pouring systems for virtually all metals including:

- Gray, ductile and malleable iron
- Steels and nickel/cobalt-based alloys
- Copper and copper-based alloys
- Aluminum, zinc and reactive metals
- Precious metals

Inductotherm also builds heating systems for high temperature and ultra-high temperature carbon processes.

As the world's largest manufacturer of induction melting systems, only Inductotherm can offer proven, efficient, reliable and productive systems for all your melt shop needs.

Inductotherm is ISO 9001:2008 registered and its VIP® induction power supplies are certified by ETL to UL, CSA or CE standards.

The Inductotherm Pledge

We give you the competitive edge by providing the best in customer service, quality and reliability, value, design and technology.



VIP® POWER SUPPLY SYSTEMS

Digital Control

- In its standard configuration, a VIP® power supply unit includes an intelligent digital control board with fiber-optic communication for clear signal processing, a bright LED panel system information display and an integral keypad for control and data entry. All control board functions can be configured via the keypad.
- For advanced computer control assistance, VIP® power supplies are available with built-in Melt-Manager® Plus® control system automation or for connection to external Meltminder® 300™ computer control systems. VIP® units equipped with Melt-Manager® Plus® control systems include a full-color LCD screen with a touch-sensitive interface.
- Remote control panels are available for all VIP® units.

Automatic Full-Power Response

- Automatic full-power response from cold charge to fully molten, melts more metal per kWh and kVA for lower melting costs and greater productivity.



VIP®-I™ Series Cabinet
with Melt-Manager® Plus®

Our VIP® induction power systems have the fastest melt rates from cold charge to pouring temperature & melt more pounds per kWh & kVA for lower melting costs and greater productivity. We have an extensive range available so please contact us to find out what system will best suit your needs.

The Fastest Melting Systems In The World

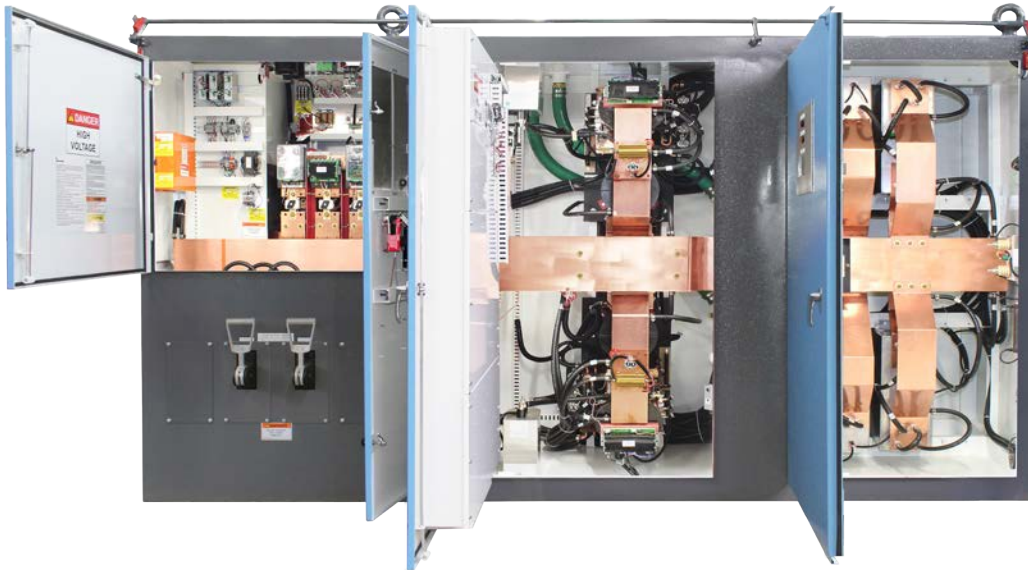

- Advanced rugged, semiconductors are designed with a 100% safety factor to ensure long service life
- Built-in protection from damage caused by electrical shorts
- Primary or secondary furnace-isolation systems provide double protection with an isolation transformer and ground leak detector system
- Husky copper bus bars, in lieu of water-cooled copper tubing, put power into the melt, not into the water system
- A network of capacitor protection systems eliminates costly downtime
- An ultra-fast-acting AC Interrupter and an Over-Voltage Protection Circuit provide the ultimate system protection. Smaller units are protected by a current limiting reactor and high-speed circuit breaker.

De-Ionized Water Cooling

- Standard VIP® power supply units are configured for connection to new or existing external de-ionized (DI) water cooling systems or to available DI water cooling modules that can be attached to the ends of the units for ease of maintenance access.

Door-within-a-door Design

- Door-within-a-door protects control circuitry from higher voltage areas while circulating air keeps compartment clean and cool, dramatically increasing circuit board life



Maximum Rating

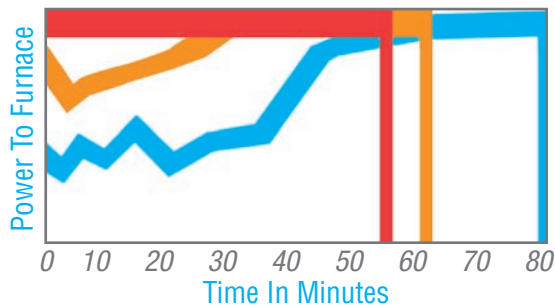

- **VIP® Power-Trak® Units:**
Continuous full power for the fastest melting time
- **Earlier VIP® Units:**
Some power drop during cold charge phase
- **Other Systems:**
Lower initial power results in long melting times

Most Efficient Ever

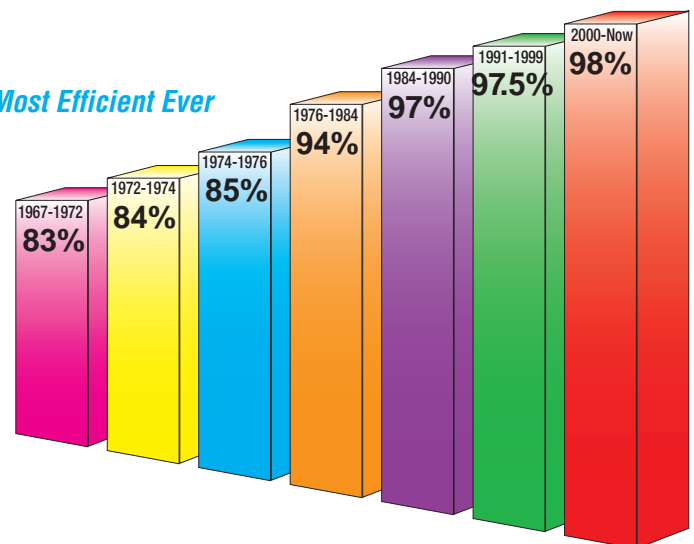

MULTIPLE-OUTPUT POWER SUPPLIES

Power two or more furnaces simultaneously for greater production with Inductotherm's VIP® multiple-output induction power supply systems.

VIP® Multiple Output Induction Power Supplies

Inductotherm's VIP® Dual-Trak® and Multi-Trak® induction power supplies are able to run several furnaces simultaneously using two or more individually controlled power outputs. In a batch melting operation this can increase metal production tremendously at the same power rating compared to a single-output power unit. These systems are available from 250 to 25,000 kW.

Multiple-output units can be configured to provide the high levels of metal production previously associated with large arc furnaces and high capacity cupola melters while offering higher metal quality and superior operational flexibility with lower operating cost.

Inductotherm also offers Dual-Melt® and Multi-Melt™ induction power supplies for heel melting and for holding applications.

Multiple-Output Induction Power Supply Units Offer Significant Advantages:

- A single power unit with the batch production capacity of multiple units
- Uninterrupted melting and precise temperature control for holding or superheating
- Simultaneously preheat, sinter, melt and/or hold in multiple furnaces
- Increased alloy flexibility

Powering Multiple Furnaces Simultaneously

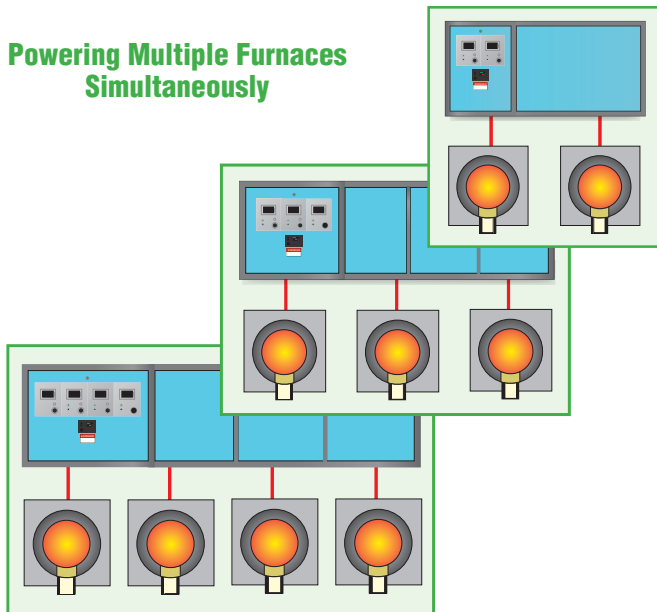

- Equipment power utilization levels approaching 100%
- Increase metal production without increasing power demand levels
- Minimum investment for each ton of metal being poured
- Separate sets of controls for each furnace
- The ability to efficiently match production to varying levels of metal demand
- Just one set of power and water connections needed, greatly reducing installation, operation and maintenance costs
- The ability to direct full rated power to one furnace while fully isolating another during maintenance

CONTROL SYSTEMS

Take control with our automated melting control systems that monitor & control the melt, diagnose faults, optimize power usage, minimize power charges & perform a variety of tasks to provide more control for complete melt shop control.

Melt-Manager[®] Control Systems

Melt-Manager[®] control systems are our entry level to smart systems that utilize embedded microprocessor controls and provide the operator with melt control modes and diagnostics for analysis and support.

The easy-to-read screen provides key diagnostic and operational information on the power supply and furnace. If abnormal conditions trigger a systems alarm, this system alerts you to the source of the problem. It also stores the information in its memory to aid in future troubleshooting. Melt-Manager[®] control systems integrate a color touch-screen LCD display that provides direct access to inverter information and controls.



Melt-Manager[®] Plus[®] Control Systems

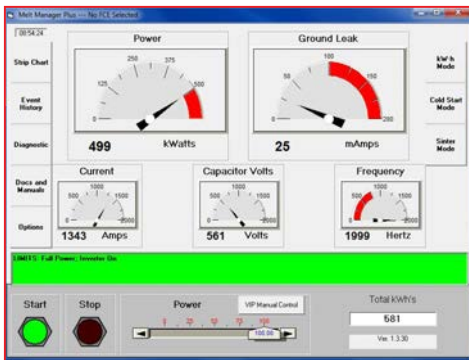

Our Melt-Manager[®] Plus[®] control system is an advanced built-in computer system that assists in performing key functions using an easy to use Windows[®]-based, full color, touch sensitive, flat panel screen for both display and control input that can be located on the power supply unit's control panel and/or on a separate remote.

The control system also has additional benefits such as: furnace preheating; automated control of the sintering cycle; virtually unlimited alarm history and operational data storage; automated collection of key operational data that can be displayed/exported for use in external management programs; remote data acquisition and network support through local or standard Internet connections; available in a wide range of languages.

Meltminder[®] 300[™] Control Systems

The Meltminder[®] 300[™] melt shop control and management system takes the successes of our Melt-Manager[®] Plus[®] control system a step further, providing precise, highly responsive and fully configurable control, which is important to the safe and efficient operation of today's high powered induction melting equipment. It is designed to be flexible, compatible and expandable for melt shops of all designs.

This control system offers custom configuration that utilizes operational settings particular to your equipment and tools needed to monitor and control the entire melting process, from charging through melting to tapping. All key process and operational data is available in both real-time and archival form, and in your preferred language and units of measurement.

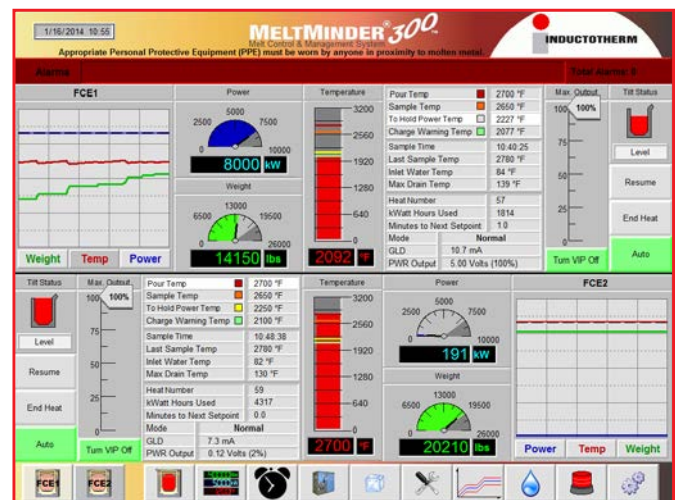

CORELESS FURNACES

Inductotherm's coreless induction furnaces offer superior performance & outstanding durability for all your melt shop needs regardless of the size of your foundry. We offer a variety of smaller induction furnaces to meet the demanding

Mini-Melt® Furnaces – Capacities from 2.5 to 25 kg

Mini-Melt® furnaces are ideal for use in prototype casting, small run casting, precious metal refining and casting, laboratory operations and wherever relatively small amounts of molten metal are needed.

- Has a strong, durable construction for long furnace life
- Operates at frequencies from 3,000 to 10,000 Hz with maximum power utilization
- Two direct-pouring styles: two-man shank and trunnion tilt
- No need for ladles or other metal transfer devices

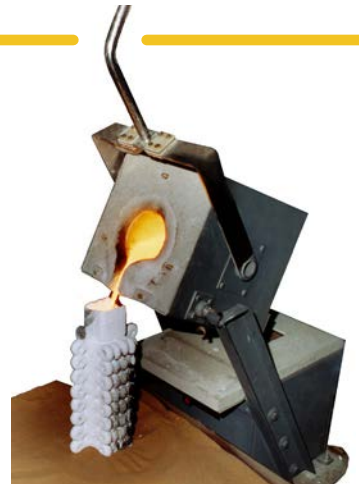

Rollover Furnaces – Capacities from 2.5 to 50 kg



Rollover furnaces are typically used in investment casting applications where precise and repeatable pours are important.

- Precision melting and pouring with high-frequency induction power for high quality, high alloy investment castings
- No ladle or hot metal transfer
- Fast mold filling (as quick as one second)
- Inert atmosphere melt covers available
- Hydraulic rollover with adjustable speeds
- Hydraulic operated mold clamp with pressure adjustment
- Consistent pouring - mold after mold

Dura-Line® Furnaces – Capacities from 25 kg to 3 MT

Dura-Line® furnaces offer high operational efficiencies with a wide choice of capacities in a budget-friendly package.

- High-strength, reinforced refractory top and bottom sections supported by cast alloy structures for firm coil support
- Maximum efficiency is provided by the free magnetic path within the furnace
- Easy, all-around access and free-breathing coil simplifies maintenance
- Rear or side exit leads are available
- Hoist tilt is standard, hydraulic tilt is available
- Stand tilt and double-trunnion tilt is available
- Available with fume exhaust assembly



requirements of investment casters, specialty foundries & the precious metals industry, as well as medium sized induction furnaces designed to give foundries another choice in small- to medium-sized applications, all the way up to our heavy steel shell furnaces for the largest foundries.

Small Steel Shell Furnaces – Capacities from 25 kg to 3 MT

Small Steel Shell furnaces are fully shunted to reduce EMF emissions and offer high operational efficiencies with a wide choice of capacities in an economical package.

- Full steel shell structure provides inherent “hoop” strength and rigidity
- Proven “free breathing” coil design using heavy section, oxygen free high conductivity (OFHC) copper tube for maximum power efficiency
- Maximum coil support minimizes refractory stress for long lining life
- Side entry power lead connection for reduced wear on power leads



Steel Frame Furnaces – Capacities from 4 to 60 MT

Our Steel Frame furnaces are efficient and easy to maintain. Their rugged construction minimizes distortion during tilting and pouring operations. Each Steel Frame furnace is designed with a high freeboard and provides extra space for solid charge materials, enabling its cover (optional) to be easily closed as the charge melts, greatly reducing heat losses. The elevated metal level height allows for easier slag and dross removal.

- Magnetic shunts cover our coil’s circumference, which redirects the electromagnetic field into the melt and away from the surrounding environment.
- Shunts are designed to provide a positive support to the coil and cushioned insulating pads reduce noise and vibration, adding to the shunts’s overall effectiveness.



Heavy Steel Shell Furnaces – Capacities to 100 MT

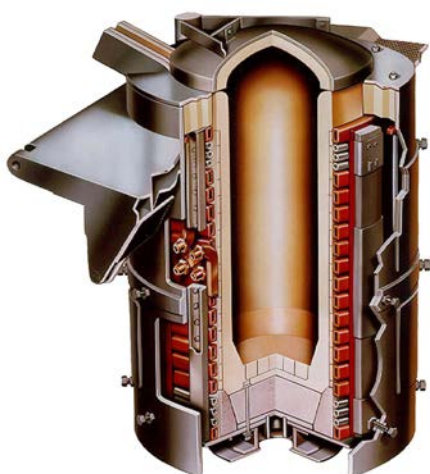

Our Heavy Steel Shell furnaces combine superior power handling capabilities with the hoop strength and rigidity imparted by the furnaces’ heavy rolled steel structure.

- Heavy-wall, water-cooled, extruded copper induction coil to maximize power efficiency
- Heavy steel shell to provide maximum furnace rigidity and strength for long lining life, low furnace noise and minimal EMF emissions
- Stainless steel cooling sections at top and bottom of the power coil to provide uniform temperature gradients that extend refractory life
- Hydraulic tilting cylinders, shrouded from dirt and metal splash, provide smooth, controlled pouring
- Water-cooled leads are protected from damage
- Wide-bodied furnace configurations are available to provide an expanded crucible opening and reduced furnace height
- Furnace load cells are available to provide accurate charge weight to simplify charge calculations

CRUCIBLE FURNACES

Inductotherm crucible melting furnaces are quick & efficient nonferrous melters with high frequency induction power. For greater flexibility when changing alloys, Inductotherm offers several removable crucible furnaces.

Acutrak® Direct Electric Heat Furnaces

The Acutrak furnace provides faster, cleaner and the most efficient melting and holding for aluminum and aluminum alloys.

- Low energy losses allow furnace to be air-cooled, eliminating the need for a water cooling system
- Holding energy cost is just pennies per hour
- High power density of 150 kW/T assures quick melting
- Clean induction technology means no fuel burners
- Metal purity is high and metal loss is low
- Metal is heated evenly and to exact temperatures with minimal overshoot
- Large diameter crucible opening makes ladling and charging easy
- Rugged construction assures high reliability and there are no fragile electrical resistance elements



Single/Double Push-Out Furnaces



Single/Double Push-Out induction furnaces provide nonferrous and precious metal casters with clean, compact and highly productive crucible melting systems.

- Coil designed for efficient energy transfer heats evenly to extend crucible life
- In double push-out furnaces, power is switched from coil-to-coil in seconds, enhancing productivity
- Hydraulic cylinders raise crucibles with minimal pressure
- Refractory overflow receptacles are designed to contain spills for added safety and ease of maintenance

Lift-Swing Furnaces

Lift-Swing induction furnaces offer nonferrous and precious metal casters an easily installed, highly productive crucible melting system.

- Specially designed base, installed directly on the foundry floor, acts as a spill pit and is integrated into the furnace to reduce installation costs
- Induction coil assembly moves easily between crucibles
- Machined slots guide coil assembly movement to exact positions for easy, accurate transfer
- Rugged aluminum shell protects the refractory and coil



KEY OPTIONS FOR INDUCTION FURNACES

Inductotherm offers a wide variety of useful options & expanded capabilities for operation and maintenance to make a cleaner, safer and more productive workplace.

Lining Push-Out Systems for Furnaces

- Greatly reduces the labor and time required for periodic refractory lining changes
- Uses a large, movable plug to push out the entire lining in minutes for easy disposal
- Increases profitability and productivity
- Improves working conditions
- Reduces exposure of foundry personnel to refractory dusting

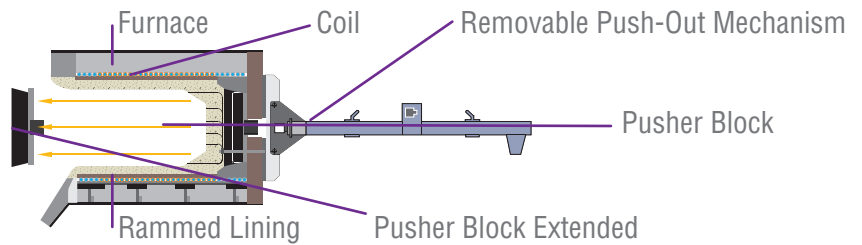

Emissions Collection System for Furnaces



Many U.S. foundries are now preparing for new and more restrictive EPA limits on air emissions. Known as MACT* standards, these proposed regulations may require the retrofit of emission controls on many foundry systems, including induction furnaces, which are already the cleanest way to melt metal.

To assist its customers with MACT compliance, Inductotherm offers a full range of emissions collection systems that are designed to:

- Effectively and efficiently collect smoke, dust and other airborne emissions during all phases of furnace operation including: charging, melting, slagging, treating and automated lining removal
- Be retrofitted to virtually all Inductotherm coreless induction furnaces, large and small, new and existing

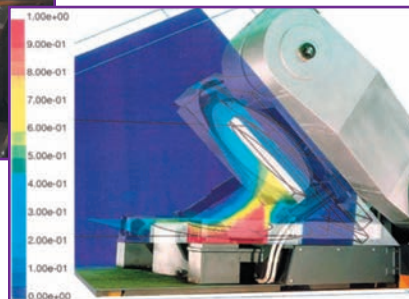

* *Maximum Achievable Control Technology*

Tilt Options for Easier Slagging & Precision Pouring

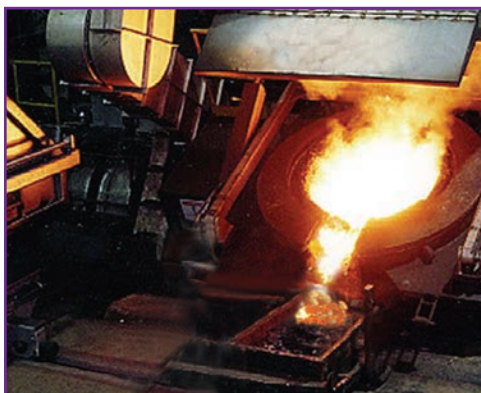

Back slagging simplifies slag removal by eliminating the need to lift heavy slag from the melt or drag it through the pouring spout. The back slagging feature permits the furnace to tilt at a 33° angle towards the rear. Tilting the furnace provides sufficient space above the deck for a portable hopper and makes it easy for the slag to be pulled through the rear spout into the hopper.

Back tilting is offered where approximately 12° back tilt angle is achieved for slag removal utilizing a lower cost tilt frame with extended cylinder construction.

Nose tilting shifts the furnace rotation point forward increasing the pouring accuracy used where small pours or a controlled pour stream is required. Pre-tilt and/or trunion pour options for a Steel Shell furnace line utilize custom tilting arrangements for special precision pouring needs.

HOLDING SYSTEMS

Inductotherm offers two types of advanced holding systems to ensure you get the system that's right for your foundry. Both choices offer true volume flexibility for continuous & batch duplexing for all metals.

Channel Furnaces – Capacities to 150 MT

Channel furnaces maintain a continuous supply of metal ready to pour twenty-four hours a day, seven days a week.

- Solid state VIP® power supply units provide electrical efficiency levels of up to 98%



- A full 80% of the vessel capacity can be used, maximizing the volume available for either continuous or batch duplexing
- Quiet, efficient water-cooled inductors
- Significant increases in productivity
- Exclusive Dynamotion™ Inductor System's superior fluid dynamics achieve the longest inductor life in the industry and produce a more uniform temperature throughout the metal batch

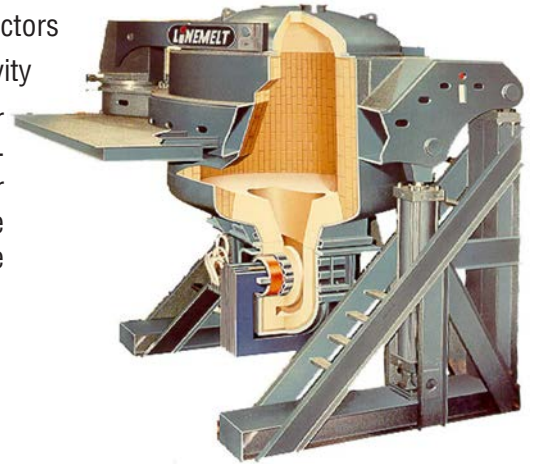
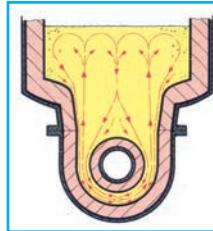

MINI-HEEL® Furnaces – Capacities to 100 MT

Inductotherm coreless Mini-Heel® furnaces maintain a continuous supply of metal ready to pour twenty-four hours a day, seven days a week.

- Patented Mini-Heel® furnace extended coil system combined with advanced VIP® unit inverter technology efficiently maintain furnace holding power and precise temperature control with as little as a 10% molten heel, providing a full 90% of metal volume for operational use
- Can be emptied completely to handle alloy changes on short notice and does not require energy-wasting off-shift holding
- Allows increased throughput
- Reduces job turnaround time
- Offers rugged construction and a quality-built steel shell to withstand the most severe melt-shop environments
- Available with all the Heavy Steel Shell furnace options

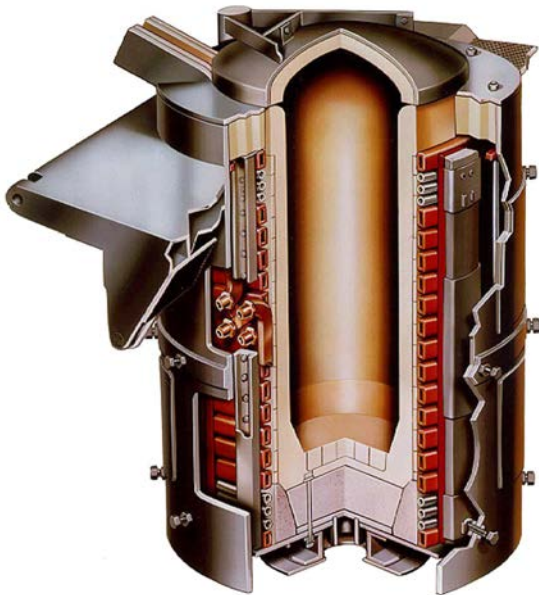

INDUCTO-POUR™ SYSTEMS

Our automated pouring systems are designed for maximum productivity and are able to provide the high level of pouring accuracy required to eliminate quality robbing under pours & metal wasting over pours.

Pressure Pouring Systems – Capacities from 1.8 to 25 MT

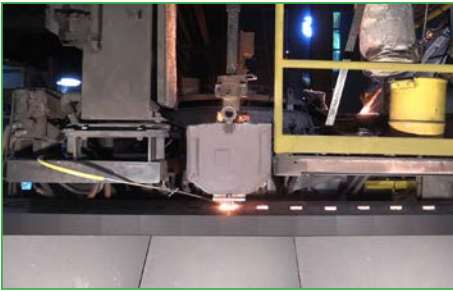

Heated Pressure Pouring Systems are typically used for high production shops where minimal alloy changes are made. They are suitable for gray, malleable and ductile iron and copper-based metals.

- Vessel design that delivers clean metal drawn from the bottom of the metal bath
- Inert furnace atmosphere that enhances the “clean metal” capabilities
- Metal storage provides uninterrupted pouring during lags in metal delivery
- Continuous temperature control fine tunes the pouring process

Tundish Pouring System – Capacities from 1 to 3 MT

Unheated Tundish Pouring Systems are designed for foundries with a semi-continuous supply of metal and where alloy flexibility is a must. They are suitable for gray, malleable and ductile iron.

- Stopper rod pouring to deliver clean metal from under the slag
- Efficiency of a refractory lining system designed to reduce metal temperature loss
- Pneumatic charging cover that simplifies metal delivery and slagging practices while reducing energy loss
- Hydraulic tilting to facilitate alloy changes and lining maintenance



Multi-Pour™ Systems – Capacities from 2 to 5 MT



Multi-Pour™ Automated Pouring Systems features our advanced VISIPOUR® P3® (Predictive Pour Performance) control technology and utilizes two or more adjustable vision-based cameras and two or more adjustable stopper rod systems to effectively pour each double indexed mold from the same vessel or from separate vessels, depending on your application.

- Stopper rod pouring to deliver clean metal from under the slag
- Efficient refractory lining system designed to reduce metal temperature loss
- Pneumatic charging cover that simplifies metal delivery and slagging practices

Tilt-Pour™ Systems – Capacities from 250 to 1,500 kg

Tilt-Pour™ Automated Pouring Systems feature a coreless induction furnace which melts a specified quantity of metal at the required temperature in close proximity to the point of pour. By pouring directly into the mold these systems offer many advantages.

- Outfitted with clever arrangement for maintaining pour stream alignment
- Finely tuned tilting control for accurate metal dosing
- Intelligent, adaptive software tracks to correct the tilt angle to accommodate physical differences with the furnace lining
- Dual furnace concept provides melting and holding temperature control



MATERIAL HANDLING

We offer material handling systems designed to enhance safety, increase energy efficiency & achieve higher productivity to help you keep pace with the rapid melt rates of today's furnaces.

Material Handling & Charging Systems

We manufacture a broad range of material handling and weighing systems for both ferrous and nonferrous melt shops. These systems include:

- Charge buckets
- Belt conveyors
- Vibratory conveyors (Pivoting, Indexing/Traversing, Storage)
- Preheating/Drying Systems
- Automated batch make-up and delivery systems for alloying materials

Manual charging operations are slow, labor intensive and dangerous. That is why foundries are turning to remotely controlled, mechanized material handling systems to transport charge material from storage areas into the furnaces quickly and efficiently.

Inductotherm's material handling equipment also serves to enhance safety by eliminating the need for melt-deck personnel to work in close proximity to the furnace during charging operations.



Drying & Preheating Systems

Preheating/Drying systems improve safety by reducing surface moisture on charge materials, thereby decreasing the risk of a water/molten metal explosion in the furnace. They can also reduce energy costs by more than 10% compared to direct cold charging. Preheating/Drying systems offer the following:

- High velocity reducing flame burners force a high speed flame through the charge while minimizing charge oxidation
- Pre-piped air and gas supply systems create precise air-fuel mixing at the burners
- Microcomputer-based burner monitoring system for implementing the burner ignition sequence and processing flame sensor feedback
- One-person control station for monitoring the complete system from charge makeup to furnace-ready charge
- Rugged vibratory conveyor that spreads the scrap underneath the burners to promote rapid and uniform heating
- Easily replaceable, wear-resistant conveyor liners, designed to withstand repeated heating cycles
- The ability to raise the charge to a uniform temperature, providing the energy necessary to increase furnace output while reducing energy costs by approximately 10%

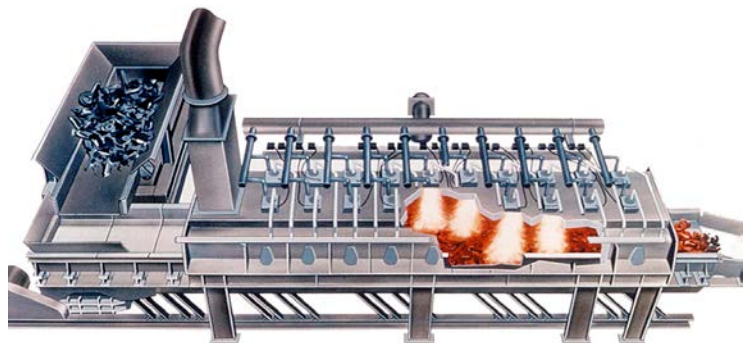

COOLING SYSTEMS

With more induction melting systems operating worldwide than any other manufacturer, Inductotherm's furnace & power supply cooling systems are proven to be suitable for virtually every climate type & temperature extreme.

Water Systems with Dry Air Coolers

- Closed-loop water recirculating systems cut both operating and maintenance costs
- Easy to install and maintain, the system consists primarily of a pump, hydronics tank, deionizer and an outdoor mounted water-to-air heat exchanger
- Zero water discharge, no water usage, complete closed pressurized circuit
- To serve two or more VIP® units, a larger pump and the hydronics components are supplied as a separate unit



Closed-Circuit Water Systems with Industrial Coolers



- Single system can be sized to cool multiple units when necessary
- Fully assembled and tested indoor pumping module includes an expansion tank, air separator, pump(s) and instrumentation
- Works in conjunction with an outdoor, closed circuit evaporative industrial cooler
- Individual temperature flow indicators and alarms for every major water circuit ensure foolproof operation and simplify troubleshooting

Dual-Loop Water Systems

- For larger induction installations, these cooling systems have separate loops for furnaces and VIP® power supplies utilizing a variety of heat exchanger configurations



DAC Xtreme, DAC Xtreme Plus & Adiabatic Cooling Systems



- DAC Xtreme, DAC Xtreme Plus and Adiabatic Cooling Systems have almost all of the benefits associated with dry air cooling along with the added benefit of not being limited by the dry bulb temperature
- Water usage is often about 40 percent less than a trim cooler to achieve the same level of cooling

Open Evaporative Cooling Systems

- Open evaporative cooling systems are designed for simple operation and maintenance
- Water-to-water heat exchanger are typically used for heat transfer between cooling tower and furnace/power supply



VACUUM SYSTEMS

The creation & casting of super alloys & other advanced & reactive metals requires sophisticated vacuum or controlled atmosphere melting & remelting systems.

Melting Systems For The World's Leading Vacuum System Manufacturers

Inductotherm is the principal supplier of induction furnaces and power supplies for the world's leading vacuum system manufacturers and precision investment casters.

Furnaces range from small vacuum furnaces with capacities measured in grams to giant vacuum furnaces with capacities of 60 MT.

- Inductotherm vacuum furnaces are designed specifically for operation in high vacuum environments and include vacuum-adapted construction methods and the industry's most advanced coil and connector dielectric insulation technologies and procedures.

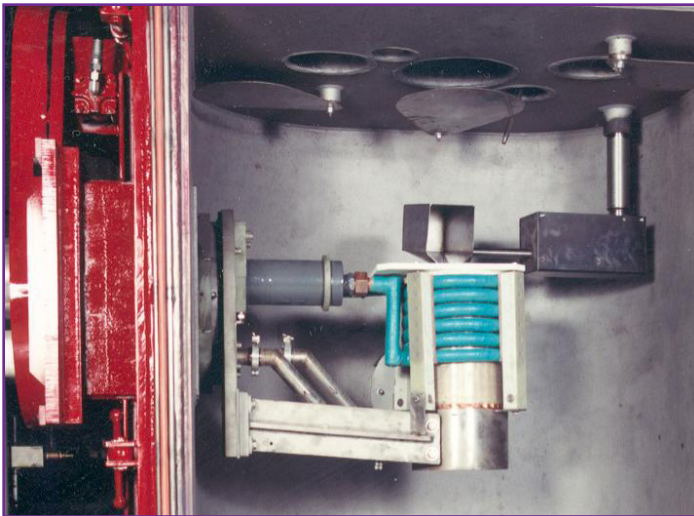

- Inductotherm builds power supply units designed for induction high resistance load melting applications for reactive alloys.
- For the production of directional solidification investment castings and single crystal investment castings, Inductotherm manufactures Dual-Switch[®], Tri-Switch[®] and Multi-Switch[™] induction power supply units and zoned power coils able to precisely control the heating applied to specific sections of the hot zone.

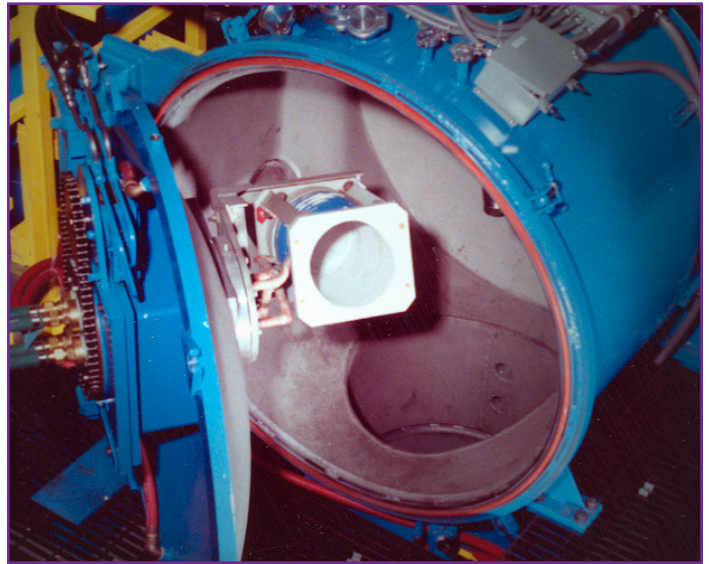

- VIP[®] induction power supply units as large as 6,000 kW have been built specifically for vacuum melting applications. Two- or three-phase unidirectional stirring for precise chemistry and temperature consistency are available.



INDUCTION HEATING

Inductotherm also builds most of the world's zoned induction heating coils & multiple output power supplies used in the manufacturing of ultra high temperature advanced materials such as carbon carbon.

Induction Heating For Advanced Materials Processing From Metal & Chemical Vapor Deposition to Carbon-Carbon Manufacturing

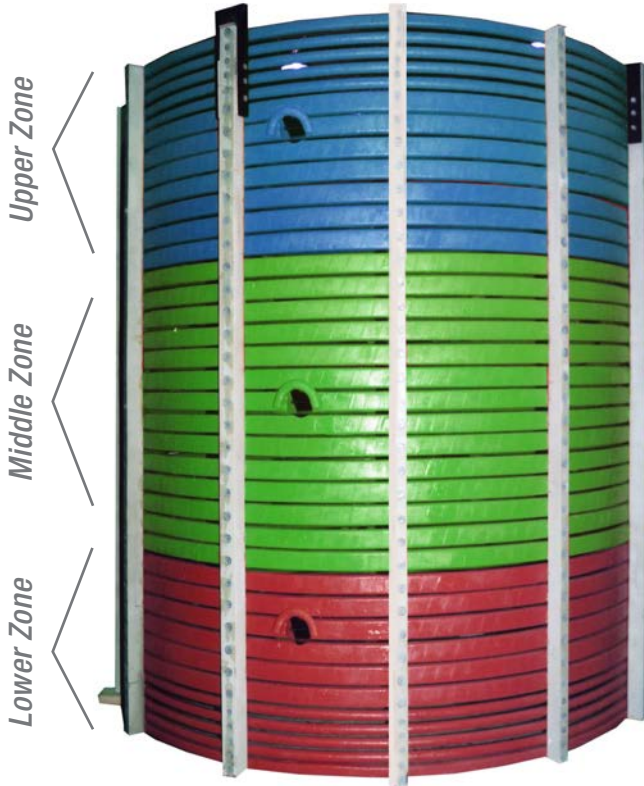

Inductotherm is not only the world leader in melting metal, we also are the leading manufacturer of induction heating systems for a variety of metal and chemical vapor deposition and carbon-based material heating processes. Our power supplies and highly specialized heating coils are widely used for:

- Heating metals, gas pressure lines and atomizing nozzles used in metal vapor deposition (MVD) processes
- Graphite heating processes used in chemical vapor deposition (CVD) and impregnation (CVI) in the manufacture of carbon-based composite materials
- Ultra-high temperature (up to 3000°C) for the processing of carbon-carbon materials

In graphite heating, maintaining the desired temperature profile within the susceptor is absolutely critical in order to achieve maximum productivity. Precise power input to each zone of the susceptor is achieved by varying either or both the overall power level and the amount of time power is switched to a particular zone of the coil during each power distribution cycle of the system.

For example, in this particular application, a three zone system, upper and lower zone temperatures are required to be uniform while the middle zone temperature needs to run cooler than the end zones.

The heating program calls for time and power to be switched to the individual zones of the coil in proportion to the amount of heating needed to maintain the precise temperatures required in each zone of the susceptor.

Multi-Switch™ Three Zone Temperature Control Heat Run

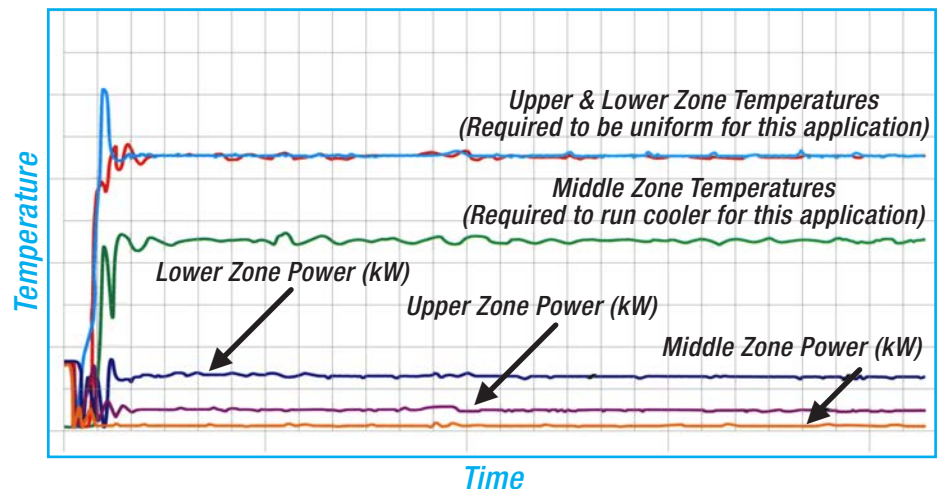

ARMS® SYSTEMS

Inductotherm offers the industry an ARMS® (Automated Robotic Melt Shop) System that relocates the furnace operator away from the deck with the help of a foundry robot. This system can be configured for any size foundry.

ARMS® (Automated Robotic Melt Shop) System

Our innovative ARMS® (Automated Robotic Melt Shop) System relocates the furnace operator from on the open melt deck to the safer melt shop control room. The operator controls integrated charging, slag removal, tool handling and remote viewing systems. The foundry robot located on the melt deck performs the required but hazardous operations that would otherwise be handled directly by the furnace operator which include:

- Checking of the metal bath grounding
- Dipping the thermocouple lance
- Adding coagulant and slagging the furnace
- Taking metal samples for chill cup, chill wedge and spectrometer coupon disk and pin
- Adding required trim materials

This allows the furnace operator to run the melt shop operations from the control room and away from the dangerous areas close to the furnace, significantly improving worker safety. Other benefits include reduced operating costs, improved worker recruitment and retention results as well as the efficiencies that come from automated operations.

Robotic systems are available with lifting capacities from 30 to 500 kg, allowing them to be configured for furnaces up to 20 MT and larger.

From his post in the control room, the furnace operator remotely controls the movement of the furnace, furnace cover, charge car and slag cart and



ARMS® System Using Slag Rake



ARMS® System Grabbing Tools



ARMS® System Using Clam Shell Slagger

initiates the preprogrammed operations of the robot. Multiple closed circuit video cameras capture operations on the melt deck and display the images on monitors located inside the control room.

Slagging can be performed by the foundry robot either by backtilting the furnace and using a slag rake or by the use of a clam shell slagger.

For more information, call 1.888.INDUCTO [1.888.463.8286] or visit www.inductotherm.com
©2015 Inductotherm. All Rights Reserved. Bulletin: M2526 Rev. 1



Leading Manufacturers of Melting, Thermal Processing & Production Systems for the Metals & Materials Industry Worldwide.

Important: Appropriate Personal Protective Equipment (PPE) must be worn by anyone in proximity to molten metal.

