

*Machines for
solid metal forming*

Die Forging Hammers



**LASCO UMFORMTECHNIK
WERKZEUGMASCHINENFABRIK**





H0 series

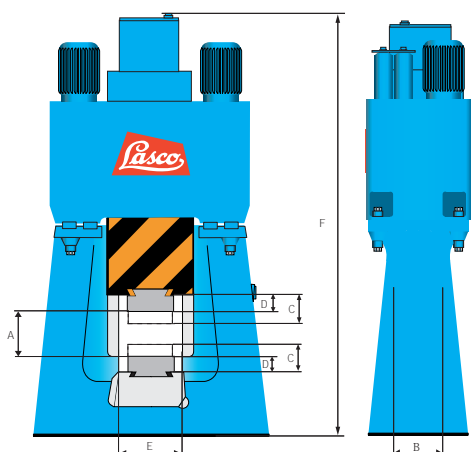

Schematic of HO-U hammer.

- A = Max. ram stroke
- B = Ram depth
- C = Max. die height without dovetails
- D = Min. die height without dovetails
- E = Daylight between guides
- F = Height above floor

H0 series		100	125	160	200	250	315	400
Blow energy	[kJ]	10	12,5	16	20	25	31,5	40
Blow frequency	[1/min]	110	110	100	95	90	90	90
at nominal working capacity								
Max. ram stroke	[mm]	570	580	640	660	690	700	710
Ram depth	[mm]	420	440	450	500	570	590	590
Max. die height without dovetails	[mm]	280	300	320	360	370	400	430
(upper and lower die)								
Min. die height without dovetails	[mm]	140	150	160	180	180	200	220
(upper and lower die)								
Daylight between guides	[mm]	440	480	580	580	650	700	700
Frame base width	[mm]	1700	1740	2290	2290	2550	2800	2800
Frame base depth	[mm]	1050	1050	1250	1400	1400	1400	1400
Overall weight	[t]	19,5	24	32,5	37,5	51	54	67
Height above floor at a height of floor	[mm]	3800	3800	4050	4300	4700	4750	4750
to upper edge of the insert of 700mm								
Main motor capacity	[kW]	30	30	37	45	55	55	2 x 45

H0 series		500	630	800	1000	1250
Blow energy	[kJ]	50	63	80	100	125
Blow frequency	[1/min]	90	85	80	80	75
at nominal working capacity						
Max. ram stroke	[mm]	730	760	810	850	1000
Ram depth	[mm]	690	750	800	900	1000
Max. die height without dovetails	[mm]	450	460	530	550	730
(upper and lower die)						
Min. die height without dovetails	[mm]	220	220	280	300	500
(upper and lower die)						
Daylight between guides	[mm]	700	800	850	850	1000
Frame base width	[mm]	2800	3000	3390	3440	4100
Frame base depth	[mm]	1600	2000	2450	2450	3100
Overall weight	[t]	78	98,5	118	164	213*
Height above floor at a height of floor	[mm]	4900	5000	5800	6050	6500
to upper edge of the insert of 700mm						
Main motor capacity	[kW]	2 x 55	2 x 75	2 x 90	2 x 90	2 x 132

*with base plate

■ All data are proposals and can be adjusted to customer's requirements.

Pioneering feat

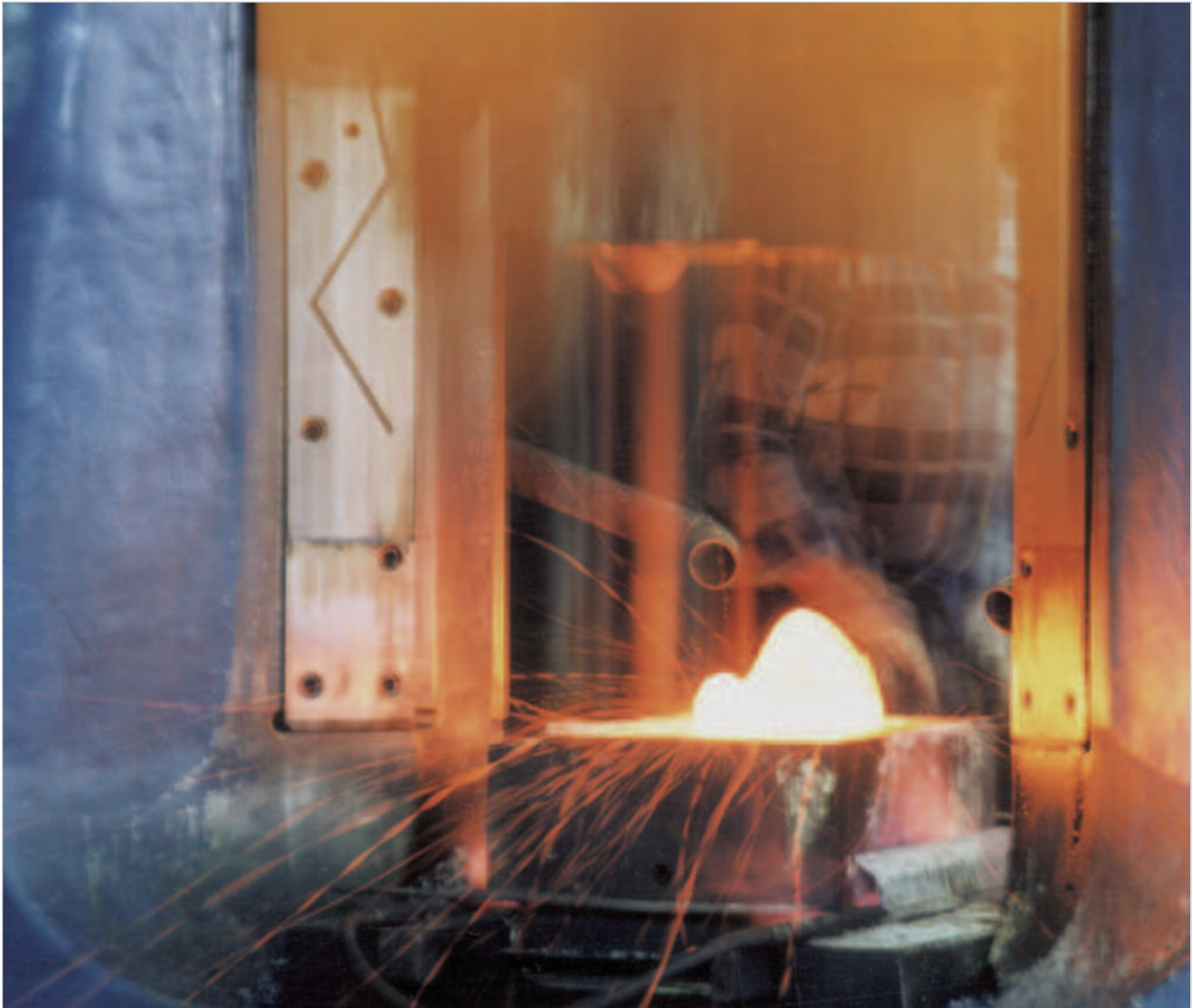

Technologically and economically, the forging hammer is still the best forming machine available to the forging industry. It provides a maximum of forming force coupled with lowest possible investment of time, cost and energy.

The forming characteristics of forging hammers are ideal for a wide range of commercially available forgings.

Many forgings, especially complicated, heavy ones, can only be

produced economically with a hammer.

The use of modern, direct spring damping has eliminated the effect of vibrations generated by the hammer on the surrounding ground.

The sound power level can be considerably reduced by partially encapsulating the hammer.

LASCO is the pioneer and inventor of hydraulic power drive systems for die forging hammers.

LASCO's over 60 years of engineering experience and continual development of hydraulic hammers has maintained its position as a leading international manufacturer of forging machines.

LASCO not only invented the first hydraulic die forging hammer. It also delivered the largest and most of the hydraulically driven hammers in the world.

Versatility



The question as to whether an anvil or counter-blow hammer is the best machine for a particular application is decided by the range of parts to be forged and, more importantly, by their size.

Up to a working capacity of approximately 200 kJ an anvil hammer

is preferred. To cover this range, LASCO offers the HO-U/HO series. For heavier blanks requiring higher working capacities, the model GH counter-blow hammer is preferred.

For almost any older hammer – regardless of manufacture – LASCO offers an energy-saving

method of modernization involving conversion to the best-suited hydraulic drive system. Electronic control in combination with a hydraulic ejector in the anvil insert in the lower ram die has made LASCO die forging hammers suitable for fully automatic operation.

Profitability

The freely programmable control of the LASCO HO-U hydraulic double-acting hammer provides a multiple of forging solutions and is a further step toward achieving higher production figures with consistent high quality.

Hydraulic top pressure accelerates the ram fastest possible to the requested impact velocity of approximately 5 m/s. This means that the blow frequency is substantially higher than with a gravity drop hammer.

The LASCO HO concept ensures:

- high forging accuracy
- high blow frequencies
- precise energy control
- simple, safe operation
- suitability for automation
- direct spring damping
- optimum die life



LASCO HO-U 250, 25 kJ blow energy, programmable control.

Progress

There are many reasons for choosing a LASCO die forging hammer. Here are just a few:

- Lower energy costs in comparison with pneumatic or steam driven machines coupled with precise adjustment of working capacity and blow frequency ensure maximum efficiency.
- Elimination of a compressor or steam network provides flexibility. The hammer is always ready for operation.
- Short reversal of stroke and short contact times considerably reduce die stress. Optimum die life is achieved by using control engineering.
- The guiding system maintains almost constant clearance in spite of ram's heat expansion.
- Excellent sealing of the piston rod is achieved with standardized seals and one-piece guide bushings.
- A fast-acting automatic safety flap prevents escape of oil.
- Varying die heights are entered by the operator and automatically corrected by the control.
- The heating system fitted directly in the oil reservoir ensures the hammer is always ready for use. This is standard on all LASCO die-forging hammers.

LASCO's world market experience in hydraulic power drives was gained from the sale and delivery of around 1200 successfully operating hydraulically powered hammers and hydraulic power drives with capacities of 6.3 to 400 kJ. This experience forms the basis for the modern design and construction of these high-performance machines.

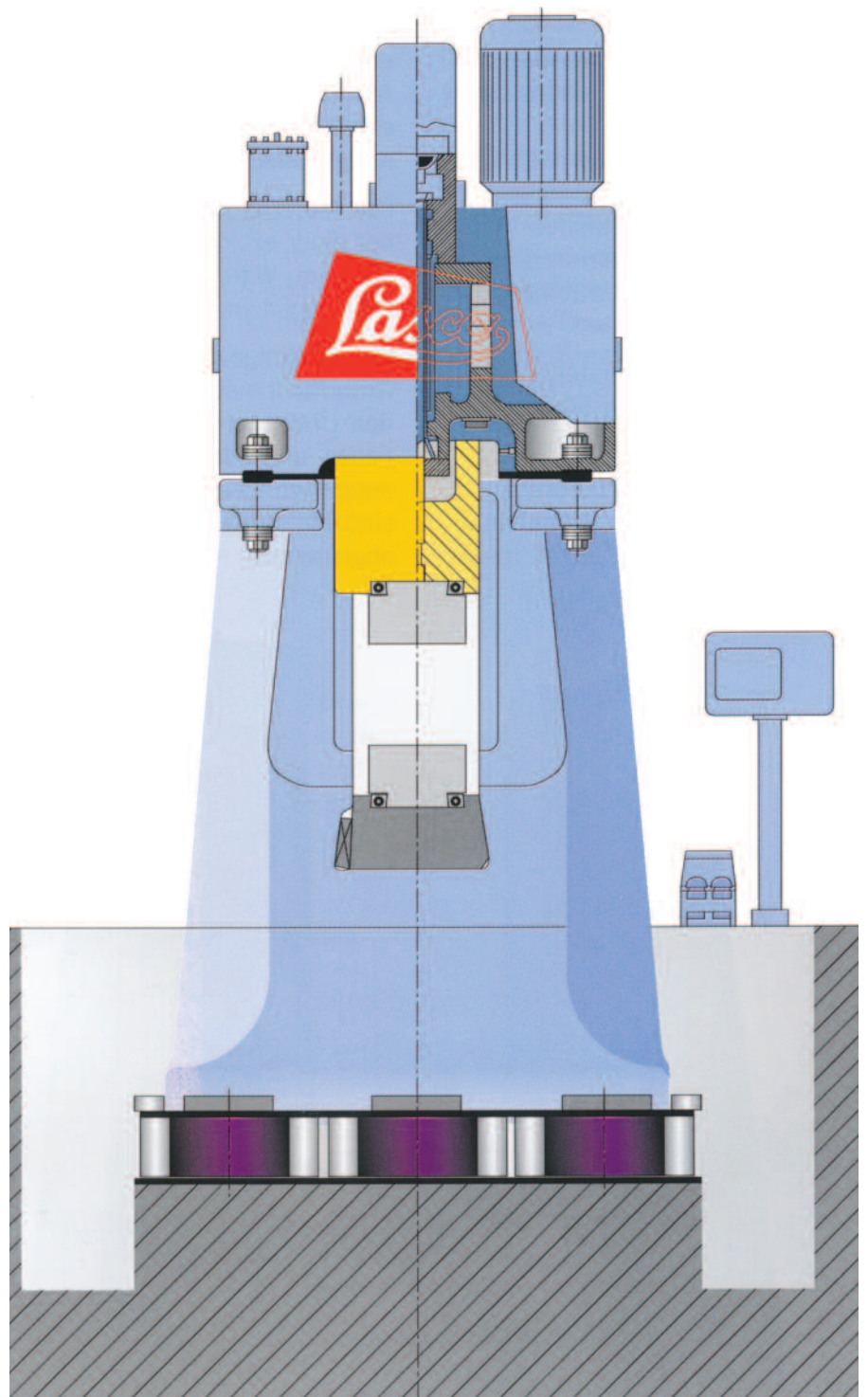

Piston rod

Solidity

Frame

Hammers with capacities up to 200 kJ are designed with a so-called U-frame. Above this capacity, the counter-blow hammer design is preferred because of anvil weight and related transport problems.

In the nineteen fifties, LASCO was one of the first hammer manufacturers to design and produce the U-frame.

The relatively short ram stroke of the double-acting drive enabled

the mass of the LASCO U-frame to be distributed ideally, ensuring high rigidity and solid design. All cross-sectional variations meet the results of photo elastic analyses.

The frame is made of alloyed cast steel that has been given a precise, controlled heat treatment.

Frame weight and base area have been designed to be mounted on spring damping elements. Frame weight and ram weight are optimally coordinated.

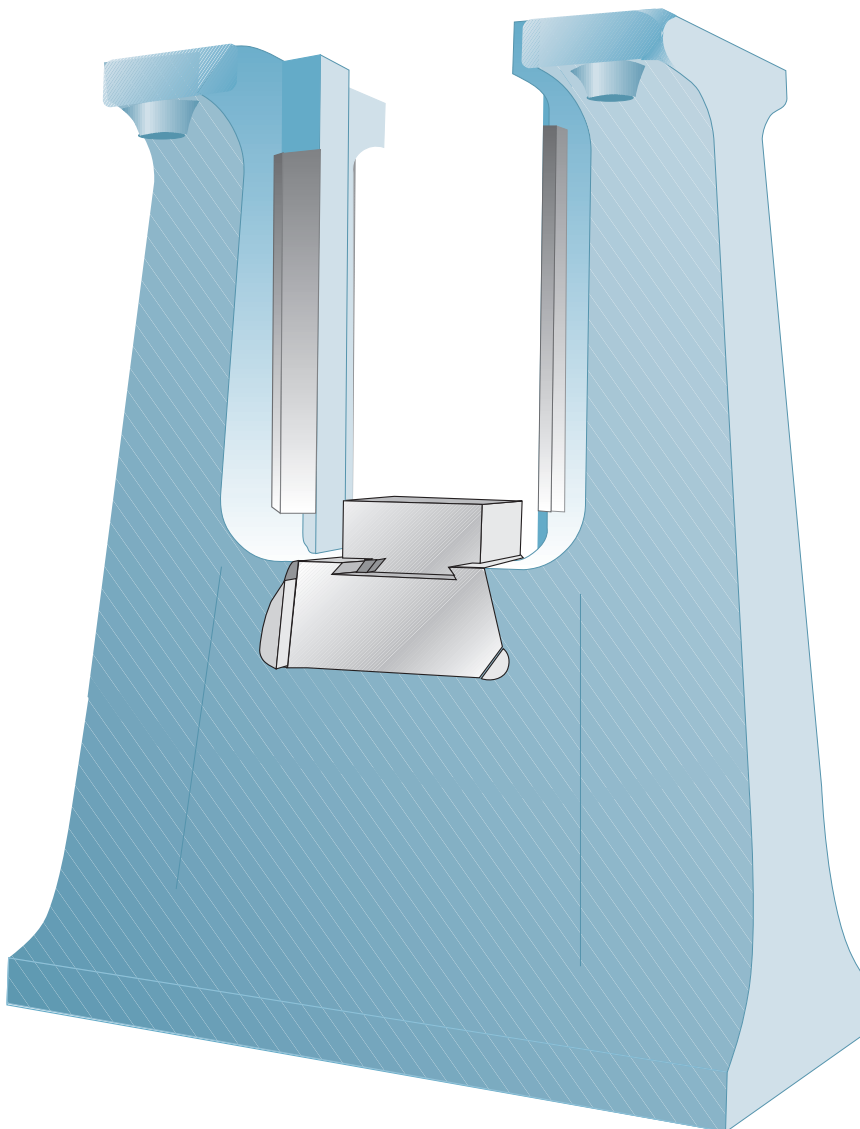

Insert block

A high-strength, generously sized insert block of hardened and tempered steel is keyed into the U-frame.

Innovation

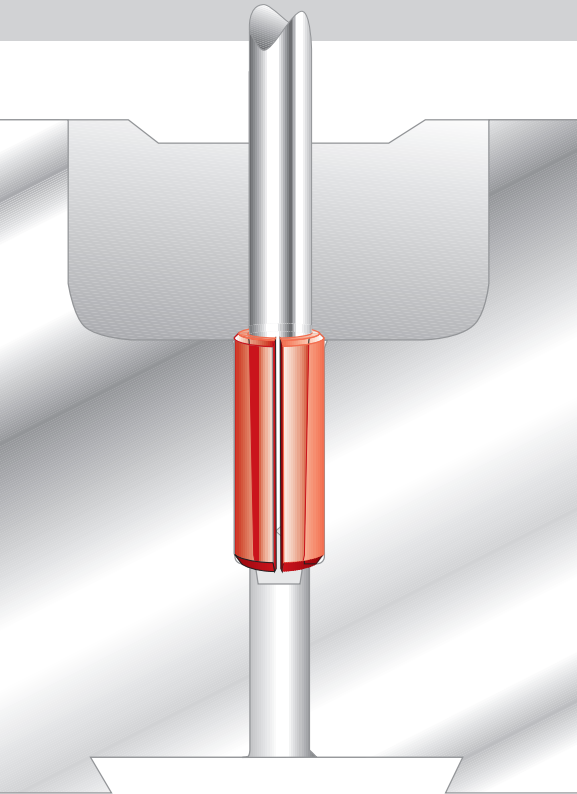

The piston rod is the most stressed component of a die forging hammer. Resulting from scientific investigations and evaluation of practical experience, both the piston rod and its anchorage in the ram have been constantly optimized. The rod is flexible and designed for minimum possible mass. The selection of a high-grade material that has passed through several finishing processes and a demanding surface treatment ensures long life.

Guiding system

The guide rails of tempered steel are arranged such the influence of temperature fluctuations between ram and frame are minimized.

Ram and ram guiding

The solid block ram is made of forged, hardened and tempered steel. The guidings are X-configured and the favorable width to height ratio of the ram ensures ideal guiding characteristics. Automatic oil pressure lubrication provides optimal gliding conditions and minimum wear.

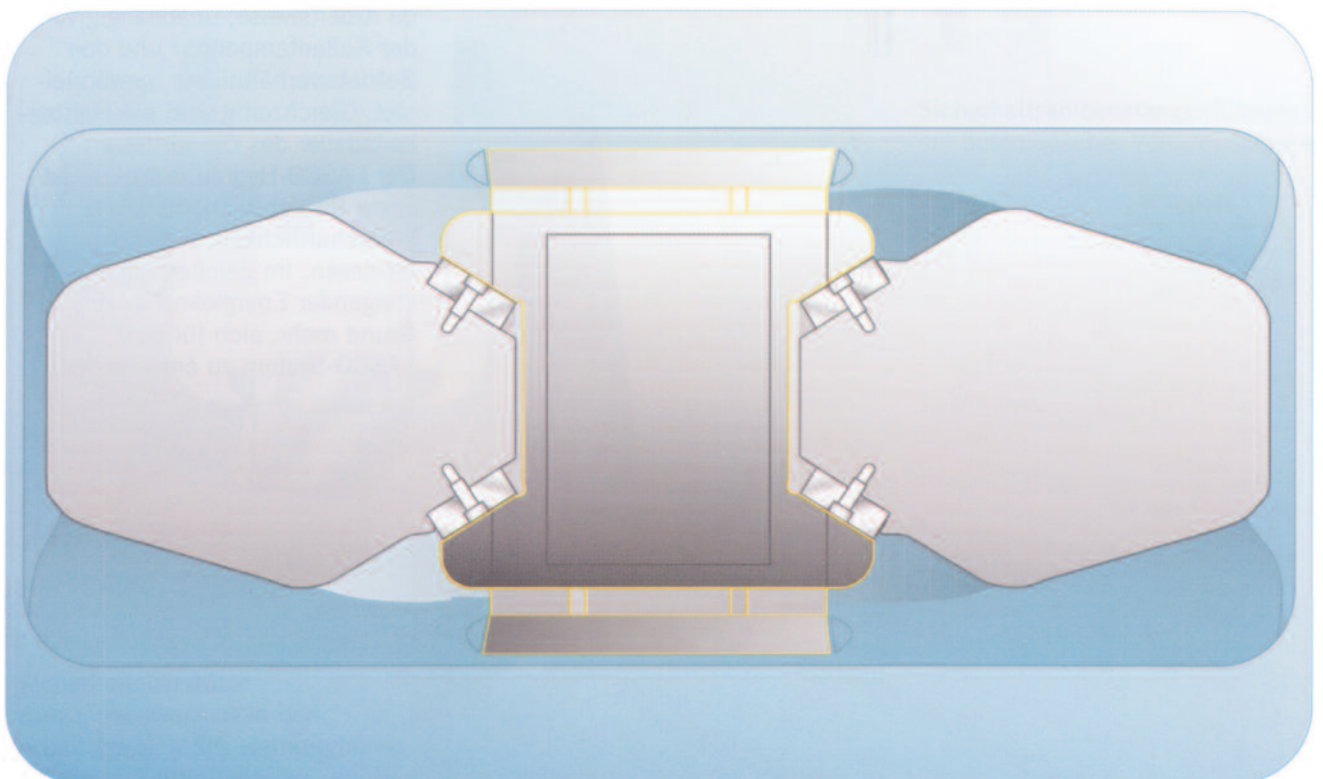

Drive

The encapsulated drive system is installed in a cast head adapted to the demanding working environments in the forge. The head also serves as an oil reservoir and is mounted with vibration damping onto the uprights. The use of a forged control block combining most of the important control elements reduces the need for pipework almost completely. This type of control system ensures high operational reliability and efficiency.

The “heart” of the hydraulic drive consists of durable axial piston pumps driven through flexible couplings by special three-phase motors. The hydraulic fluid is constantly purified by monitored filtration. Constant, optimal fluid temperature is guaranteed by automatic temperature control, which, in turn ensures consistent performance unaffected by ambient temperature and operational conditions and prolonged life of the hydraulic fluid. LASCO's hydraulic drives have proved their operational reliability over a thousand times. In times of rapidly rising energy costs, this is one more reason to choose a LASCO product.

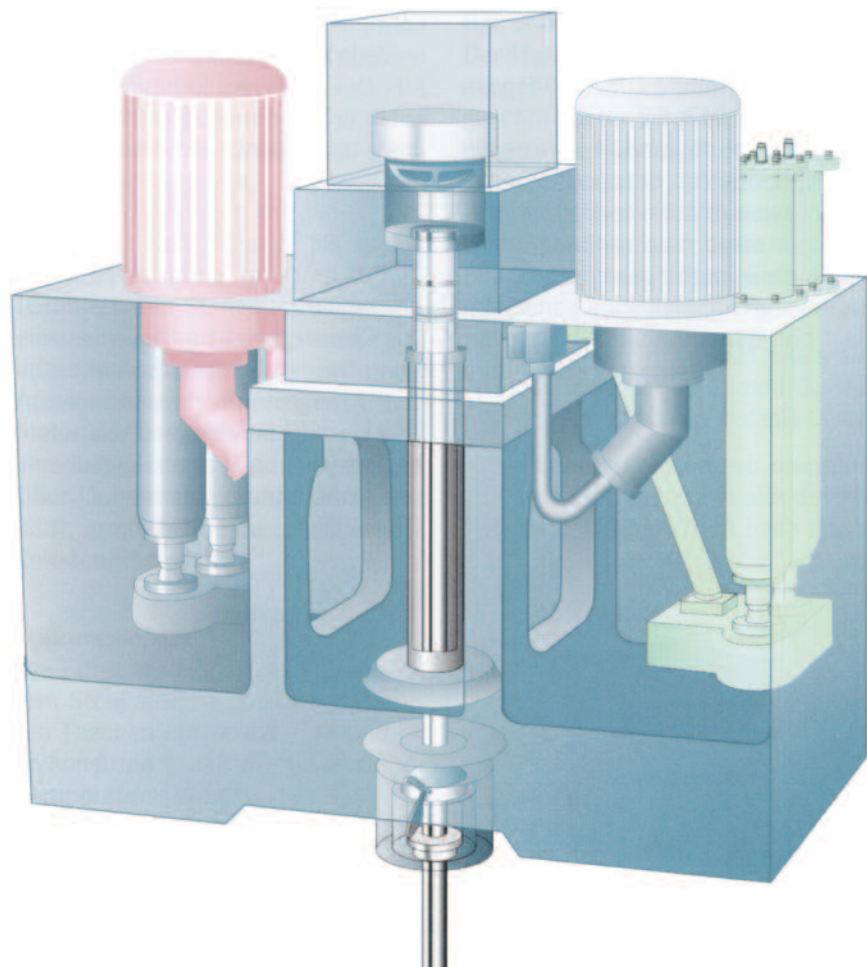

Safety

Operator and operational safety are given high priority at LASCO. This is why LASCO equips its machines with safety systems that go beyond safety regulations.

Safety module

prevents an uncontrolled delivery of blows. It can also be retrofitted on older LASCO hammers.

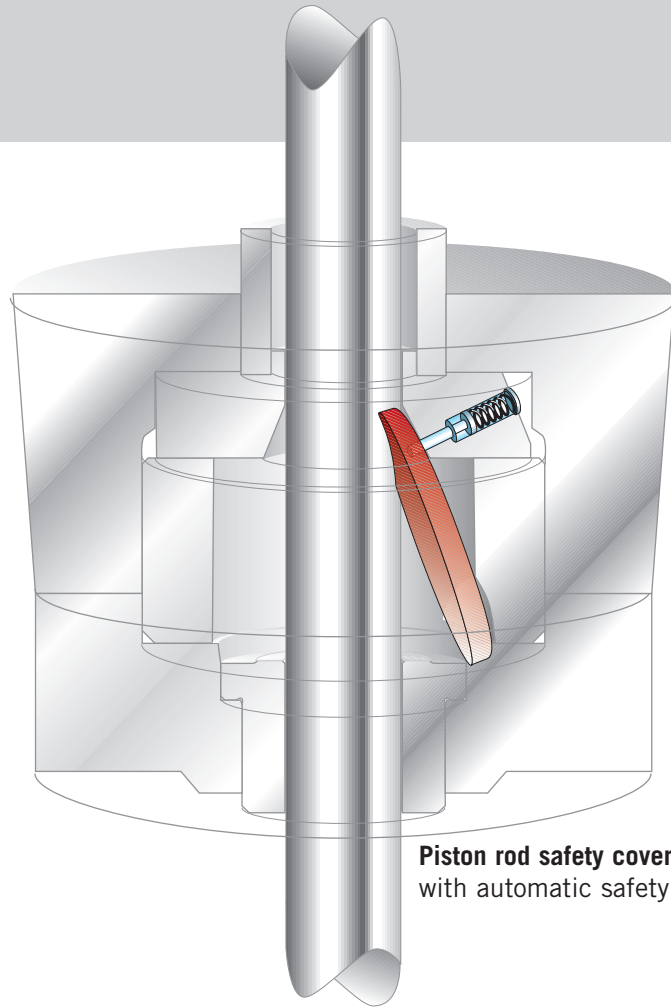

Piston rod safety cover
with automatic safety flap.

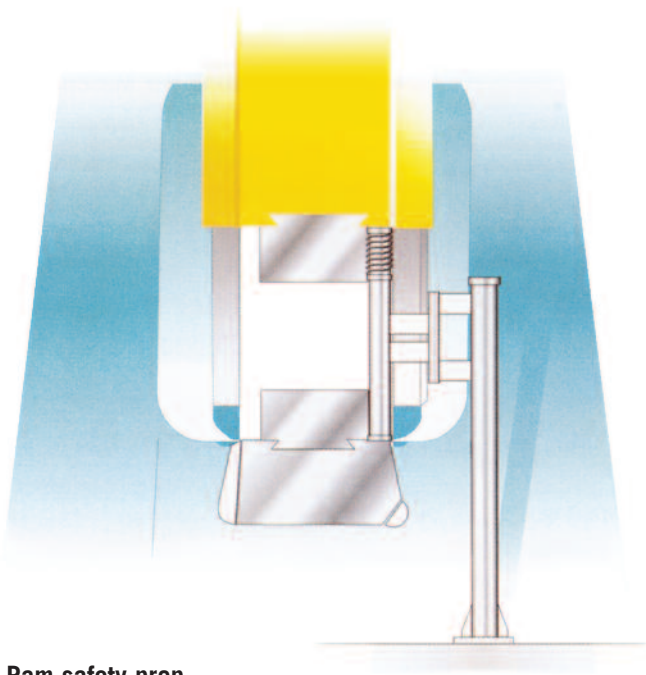

Ram safety prop

can be swiveled into the working space and is electronically controlled.

Performance

The experience gained in the manufacture and operation of hydraulic anvil hammers formed the basis for development of hydraulic counter-blow hammers.

With regard to handling, efficiency and safety, these metal-forming machines meet the high demands of the forging industry just as competently as anvil hammers.

The LASCO GH concept ensures:

- high forging accuracy
- high blow frequencies
- suitability for automation
- precise energy control
- optimum die life
- simple, safe operation
- direct spring damping



LASCO GH 2500, 250 kJ blow energy, weight: approx. 150 000 kg, programmable control.

Innovation

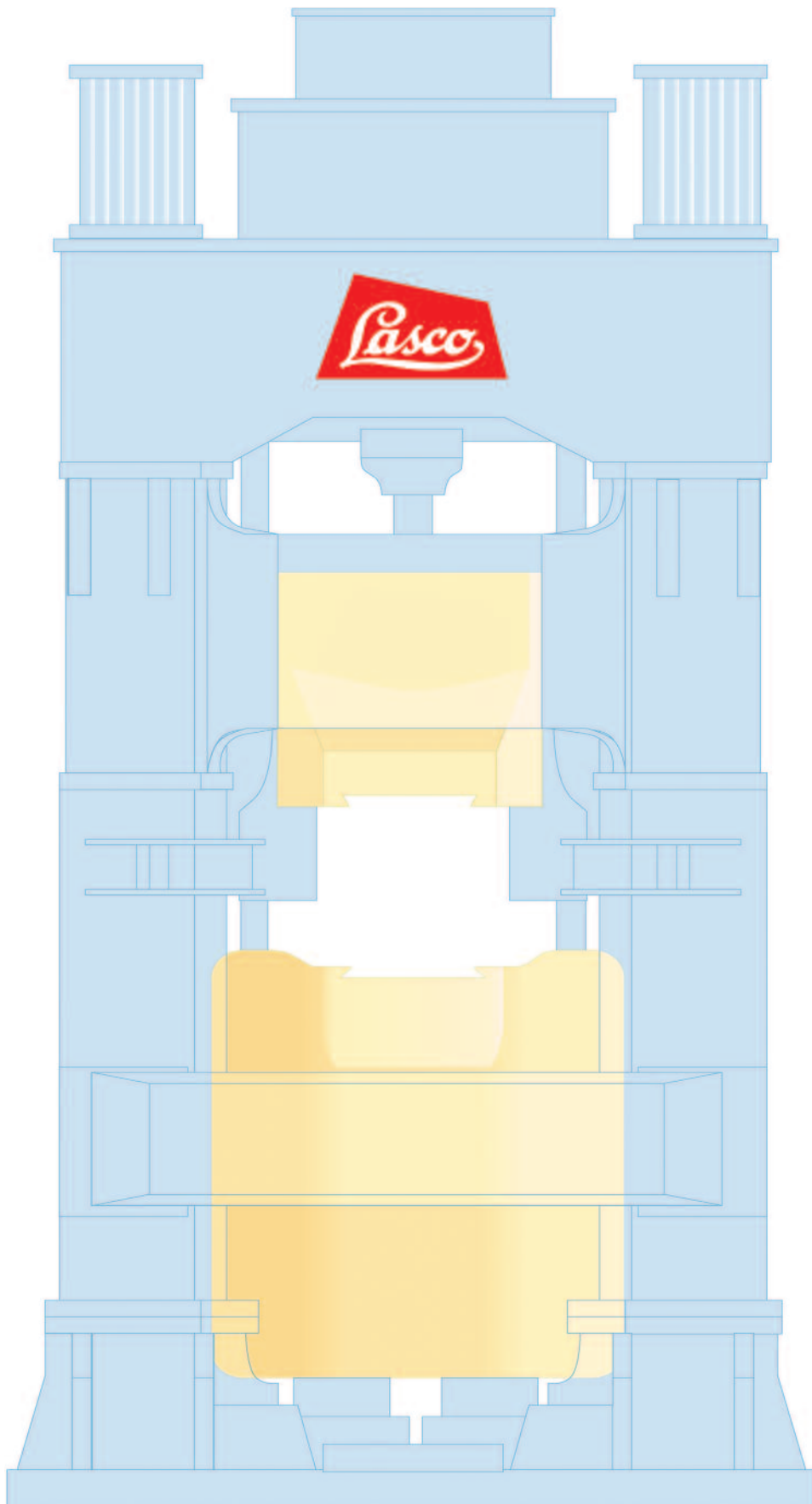

The rams of the counter-blow hammer have unequal masses. The mass ratio of the upper to the lower ram is 1:4 to 1:5, depending on size. On smaller counter-blow hammers, the upper ram is guided into the lower ram. On larger counter-blow hammers, the lower ram is guided into a solid cross beam of cast steel that absorbs all lateral forces.

Crossbeam and uprights for the lower ram are connected to each other with form-fitting joints. Combined spring damping elements may be fitted under the base.

Section through a counter-blow hammer

The working principle

The resulting ram impact velocity is around 6 m/s. The ram strokes are constant. Varying die heights, for example after die change, are automatically compensated. Because of the chosen mass ratio, the lower ram moves at a final velocity of only 1.2 to 1.5 m/s.

Similar forging conditions exist as for anvil hammers. The chances of the blank jumping out or shifting is significantly less than with conventional counter-blow hammers with rams of similar mass. The installation of ejector systems within the hammer's working space is also facilitated because of the short stroke of the lower ram and, therefore, also an automation of the hammer.

During the reverse stroke, the air cushions located under the lower ram dampen the impact when the ram reaches its end position, reducing the forces absorbed by the foundation and allowing the dissipating energy to be captured directly. This is a further advantage in comparison with counter-blow hammers of conventional design.

Drive

The drive system is encapsulated and installed in block construction on the head crossbeam. In its design and construction it is, largely, the same as the drive for the anvil hammer. The lower ram is pressed down against two air cushions into its starting position by two plungers. The rams are not connected, neither mechanically nor with a hydraulic coupling. Their motions are precisely controlled by the hydraulic drive system.



Frame

The frame is a multiple element cast steel and welded construction. It consists of a solid base plate, the uprights and the crosshead. Pneumatic springs for the lower ram drive are installed in the base plate. The uprights are anchored centrally to the base plate, incorporating the guides for the lower ram. The crosshead is fixed on the uprights, carrying the control block for the complete hydraulic drive system. In addition, extra guides for the upper ram and the ram-locking device are built into the cross-beam.

Safety systems for the piston rod, ram and ram guidance

These systems are also largely similar to the LASCO HO-U machines.

Enhanced control

Decentralized process control

The “brain” of every modern machine tool is its decentralized process control. As LASCO is totally customer focused, all configuration and programming is performed in-house.

LASCO's core competence in software programming and in the design and installation of electronic and electric components allows the consideration of all customer requests that are technically feasible, including the provision of interfaces for integration of existing processes and interlinked operations.

LASCO process and machine controls offer all the performance characteristics of a modern production organization, such as:

- centralized, product-related setting and evaluation of all machine parameters
- product data administration, optionally with data base link
- operating data registration
- product follow-up
- integration in MRP
- integrated maintenance programme
- integrated data logger

The requests of the customer are also considered, when designing man-to-machine interfaces, as well as specific screen menus and charts (available in several languages).

The operator is guided by a graphic colour display, which is in the same language as the messages displayed at the terminal. The registration, evaluation and listing



LASCO designs the operator menus and screen forms individually according to the customer's demand, in this case located in China.

of data can be input simultaneously during operation and the data can be transferred to the network via interfaces.

Software modules specific to the customer can be linked. Options of integrated phone- or internet-aided online maintenance systems are offered.

Efficient interfaces ensure the real time communication with automation systems and industrial robots. In principle, a data logger is integrated and offers the possi-

bility of archiving internal and external analogous and binary signals.

LASCO control concepts are decentralized on the basis of bus systems. Only hardware of international industrial standards is selected. This permits customers the possibility of making adjustments and performing maintenance work on their own as well as reprogramming and enhancing at a reasonable price. Not least this means a high security of investment.

Versatility

The variety of forged components and materials forces the need for special equipment. In order to provide flexible adaptation to various forged product ranges, LASCO can offer comprehensive options.

Position and speed measurement

With the help of sensors, the controller is able to register the position of the rams. This allows the energy to be controlled such that the required thickness of the blank is achieved with highest accuracy. At the same time, the energy used for each blow is measured.

Noise reduction

Encapsulation reduces the sound power level.

**Spring damping system**

Vibrations emitted by the hammer can be absorbed almost completely. Forging hammers have become environmentally friendly.

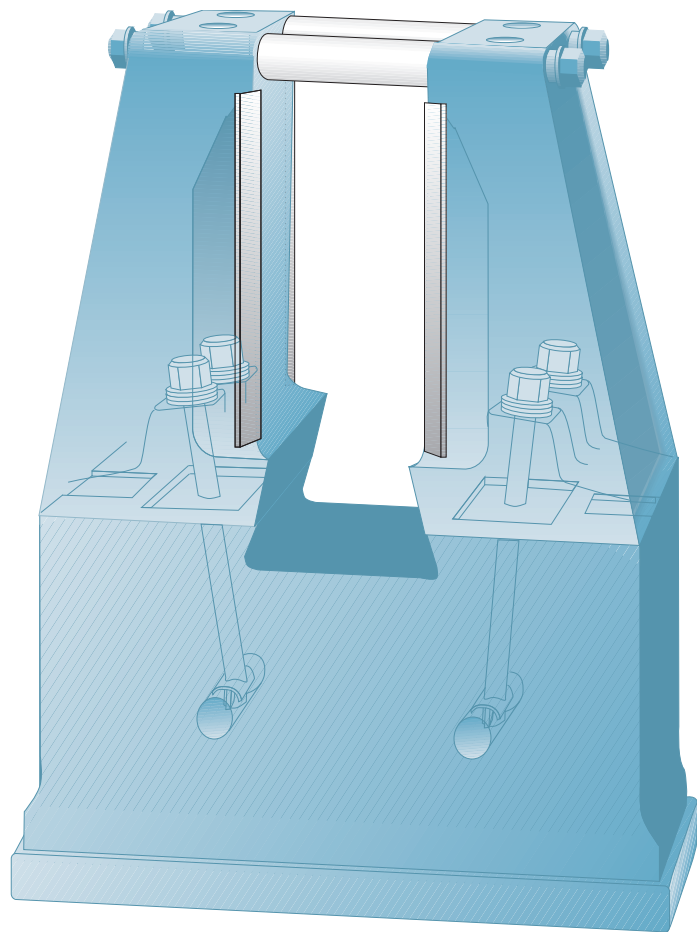
**Multi-piece frame**

Multi-piece frames are used for working capacities exceeding 200 kJ. If required, smaller hammers can also be designed with.

Online maintenance

This system allows access to the control process for service technicians in the LASCO headquarters. LASCO experts can call up control functions and carry out analyses, remote diagnosis and online optimization.

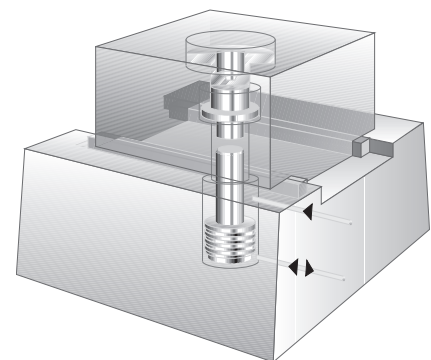
**Hydraulic ejector**

These ejectors enable smaller die angles and closed die forging.

Robots as operator



A fully automated die forging hammer from LASCO with synchronized forging robots.

With the help of modern hydraulics, control and sensing technology, coupled with a whole range of patented features, LASCO has drastically enhanced the range of applications for die forging hammers. LASCO hydraulic die forging hammers fulfill all the demands placed on metal-forming machines regarding process capability and efficiency. As the first manufacturer of machine tools worldwide, LASCO has realized fully automation on die forging hammers.

Components

A sensor patented by LASCO designed for the demanding environment which is found in the forging industry measures ram position and velocity. The system detects, for example, if the die is closed, whether the part is fully forged or whether a further blow is required. The detected ram speed is compared with the preselected value. This allows compensation to be made for any external influences that may have an effect on the system.

The essential key component of automatic hammer forging is the patented forge gripper that holds the part accurately in the required position during all operations.

The robot works on the principle of a human operator: taking up the billet with the gripper – positioning in the impression – deliberate yielding during the blow (without releasing) – lifting – transferring to the next impression.

Special, adapted and commercially available industry robots are used for handling. The synchronous master-slave operation of two robots provides a number of benefits: The billet is initially gripped at both ends and then synchronously cycled through the individual forging operations in the impressions. This allows to forge safely and remove longer blanks in multiple die cavities configured in a row.

Complex requirements

The forge grippers have to fulfill complex requirements:

- safe positioning in the impressions
- safe absorption of acceleration forces and relief of robot axes
- compensation for changes in the length of the billet
- deliberate release when the billet adheres to the upper die
- general suitability for the demanding working environments which exist in the forging industry

Programming

The overall system is programmed via a special user surface on the central process control. The programmer enters the essential parameters and only a few points are taught die installation. The actual programming of the robot is taken over by the master control.

Increase quality and save costs



The patented gripper from LASCOPAT is the key to automation of die forging hammers.

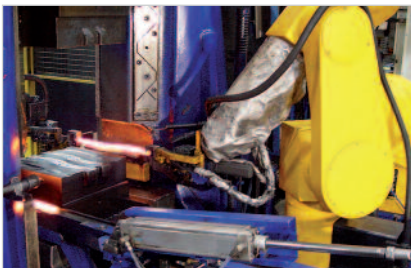

Longer blanks can be forged in multiple impressions using LASCOPAT grippers.

Benefits

The possibilities for installation of a forging line are just as diverse as the parts to be manufactured. The main advantages of automatic hammer forging are:

- process stability
- exclusion of positioning errors
- savings in personnel costs
- increase in output
- increase quality of the forged parts
- reduction in scrap rate
- enhancement of multiple impression forging



A fully automatic forging line for the manufacture of hand tools.

Hydraulic drive systems

All the benefits of the hydraulic drives from LASCO can be applied to other types of hammer drives. The HO drive was specially designed for the conversion of hammers with short stroke, light ram and limited space in the working space of the hammer. LASCO offers a specially adapted hydraulic drive for the conversion of long-stroke hammers. This overall concept guarantees high efficiency and accuracy.



Hundreds of completed conversions and modernizations in the performance range 6.3 to 125 kJ are evidence of LASCO's competence.

The conversion of all types of hammers with modern LASCO drives offers several advantages, including:

- energy savings
- high blow speed
- precise energy control
- modern control technology



An old belt lift hammer with 30 kJ of blow energy converted to hydraulic drive.

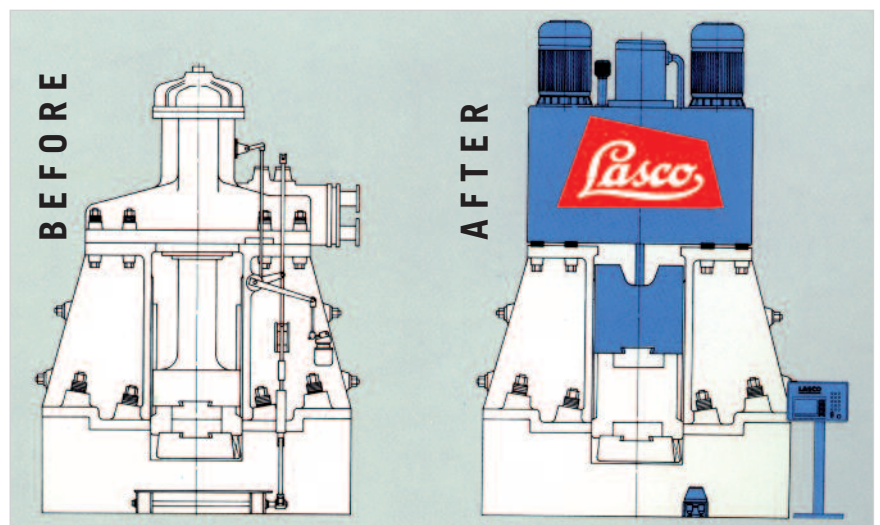

A pneumatic double-acting hammer with 40 kJ blow energy, before and after conversion to a LASCO hydraulic drive.

GH series

A = Max. ram stroke
 B = Ram depth
 C = Max. die height without dovetails
 D = Min. die height without dovetails
 E = Daylight between guides
 F = Height above floor

Schematic of GH hammer.

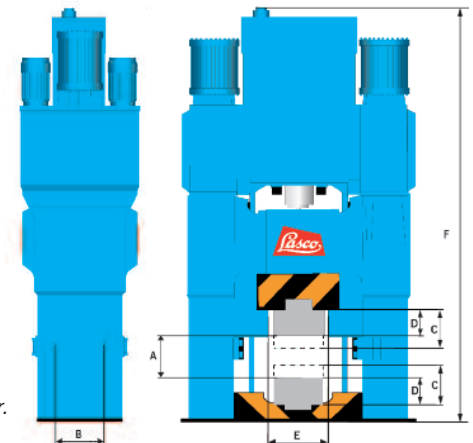

GH series	630	800	1000	1250	1600	2000	2500
Blow energy [kJ]	63	80	100	125	160	200	250
Max. stroke of lower ram [mm]	100	105	125	125	135	140	145
Max. stroke of upper ram [mm]	430	440	495	500	535	540	550
Ram depth [mm]	750	900	1000	1100	1200	1250	1400
Max. die height without dovetails [mm]	450	500	550	620	700	760	820
Min. die height without dovetails [mm]	300	320	340	370	400	440	490
Daylight between guides [mm]	660	710	770	830	900	970	1040
Frame base width [mm]	2440	2800	3000	3200	3420	3800	4200
Frame base depth [mm]	1400	1520	1650	1800	1900	2100	2400
Overall weight [t]	46	57	73	89	112	142	178
Height above floor at a height of floor [mm] to upper edge of the insert of 700mm	5100	5700	6000	6200	6400	6900	7500
Main motor capacity [kW]	2 x 45	2 x 55	2 x 75	2 x 90	2 x 110	2 x 145	2 x 160

GH series	3200	4000
Blow energy [kJ]	320	400
Max. stroke of lower ram [mm]	145	150
Max. stroke of upper ram [mm]	565	575
Ram depth [mm]	1600	1800
Max. die height without dovetails [mm]	880	960
Min. die height without dovetails [mm]	570	620
Daylight between guides [mm]	1130	1220
Frame base width [mm]	4500	4900
Frame base depth [mm]	2600	2900
Overall weight [t]	240	320
Height above floor at a height of floor [mm] to upper edge of the insert of 700mm	7800	8400
Main motor capacity [kW]	2 x 200	4 x 145

■ All data are proposals and can be adjusted to customer's requirements.



www.lasco.com

Headquarters:

LASCO Umformtechnik GmbH
Hahnweg 139
96450 COBURG
GERMANY
Phone +49 9561 642-0
Fax +49 9561 642-333
E-mail lasco@lasco.de
Internet www.lasco.com

LASCO FRANCE

1, allée des Cèdres
78860 SAINT NOM LA BRETÈCHE
FRANCE
Phone +33 1 3080-0528
Fax +33 1 3080-0584
E-mail thierry.lebailly@lasco.de

LASCO USA

LASCO Engineering Services L.L.C.
615 Harbor Avenue
MONROE, MI 48162
USA
Phone +1 734 241-0094
Fax +1 734 241-1316
E-mail lasco@lascoUSA.com
Internet www.lascoUSA.com

LASCO CHINA

LASCO (Beijing) Forming Technology Co. Ltd.
Huateng Tower, Unit 1706A
Jia 302, 3rd Area of Jinsong,
Chaoyang District
100021 BEIJING
P.R. CHINA
Phone +86 10 8773 0378
Fax +86 10 8773 0379
E-mail lasco.beijing@lasco.de