





IMPORTANT!

The latest Operating Manuals and Parts Catalogues are available on our website:
<http://www.metalfach.com.pl/en/materialy-do-pobrania>

TRAILER DATA:

Vehicle type:		Farming truck trailer for bales
Commercial designation:		T009, T014*
Type designation:		T009, T014*
Trailer identification number ^{1/} :	
Trailer manufacturer:		"METAL-FACH" Sp. z o. o. 16-100 Sokółka, Poland ul. Kresowa 62 Tel. +48 85 711 98 40 Fax: +48 85 711 90 65
Sold by:	Address:
	Tel./Fax
Date of delivery	
Owner/User	Full name
	Address
	Tel./Fax



IMPORTANT!

Hint: Please note down the trailer type and serial number - it will be required for contact with your authorised dealership.

^{1/} The data is found on the trailer nameplate located on the trailer chassis front crosspiece
*delete as applicable

CONTENTS

1.	INTRODUCTION	5	5.3	Shipping to user	22
1.1.	Intended use	5	6.	OPERATION INFORMATION	22
1.2.	Equipment	5	6.1.	Commissioning the trailer	22
1.3.	Machine identification	8	6.2.	Loading the platform	23
2.	GENERAL SAFETY RULES	9	6.3.	Travelling on public roads	23
2.1.	Symbols and nomenclature	9	6.4.	Unloading	23
2.2.	Obligatory notification	9	6.5.	Decoupling from the tractor	24
2.3.	General safety regulations of work and use	9	7.	SERVICING	24
2.3.1.	Safety of operation	10	7.1.	Servicing instruction for adjusted trailer components	24
2.3.2.	Tyres	11	7.1.1.	Wheels – bearing clearance adjustment	24
2.3.3.	Pneumatic system	11	7.2.	Brakes	25
2.3.4.	Periodic maintenance	11	7.2.1.	Brakes – adjustment of the braking system components	25
2.3.5.	Travelling on public roads	12	7.3.	Wheels – tyres	26
2.3.6.	Warning/information signs and text on the trailer	12	8.	TROUBLESHOOTING	27
3.	TECHNICAL CHARACTERISTICS	14	9.	PERIODIC MAINTENANCE	28
4.	GENERAL DESCRIPTION OF DESIGN AND FUNCTION	18	9.1.	Lubrication	28
4.1.	Chassis	18	9.2.	Maintenance and servicing	28
4.2.	Loading space	18	10.	MACHINE DISPOSAL	29
4.3.	Electrical system (signalling and warning)	18	11.	RESIDUAL RISKS	29
4.4.	Braking system	19	11.1.	Description of residual risks	29
5.	STORAGE, SALE AND SHIPPING TO USER	21	11.2.	Assessment of residual risks	30
5.1	Storage	21	12.	WARRANTY CONDITIONS	30
5.2	Sale	21	13.	WARRANTY CARD	32

1. INTRODUCTION

The Operating Instructions contain the operating performance data and the requirements for safe and professional operation of the machine which enable the best use of the product with the maximum operating life and reliability. They also contain information about ordering spare parts.

Thorough understanding of the Operating Instructions will help the user prevent accidents, operate the machine efficiently and keep the warranty valid.

Unauthorised modification of the trailer design may release the manufacturer from liability for resulting damage and loss.

METAL-FACH Sp. z o.o. reserves the right to introduce changes without prior notice and without assuming any obligations resulting from those changes.

ALL OPERATORS OF THIS TRAILER MUST UNDERSTAND THE CONTENTS OF THE OPERATING INSTRUCTIONS BEFORE COMMENCING WORK. THE MANUAL IS A PART OF THE T009/T014 TRAILER ESSENTIAL EQUIPMENT.

This is intended to maintain proper operation of the trailer, safety of use and maximum operating life. This is also the condition which ensures that your warranty rights are maintained.

1.1. INTENDED USE

The T009 (T014) trailers are intended for transport of straw or grass silage bales. The large loading surface area of the platform enables optimum usage of the trailer capacity. This is the prime advantage of trailers of this type, given the large volume and relatively low weight of straw bales.

The trailer is designed for coupling with farming tractors of varying power ratings, equipped with a power outlet for the electrical lighting and warning systems and the braking system of hitched machines, and a transport hitch.

Do not use this trailer to carry fuel, gas cylinders and similar loads due to the compliance requirements for transport of hazardous materials.

- Any use than indicated above is unintended use. The manufacturer shall not be liable for any resulting damage as it is solely incurred by the owner.
- Intended use also includes compliance with the operating, servicing and maintenance requirements established by the manufacturer.
- The trailer shall only be used by persons who have understood the Operating Manual and who have been trained in hazards and first aid for accident victims.
- Follow all applicable laws for accident prevention and any other recognised rules of engineering safety, work medicine and road traffic safety.
- The manufacturer shall not be liable for damage from any unauthorised modifications of this trailer's design.

1.2. EQUIPMENT

The essential equipment of each trailer includes:

- Operating Instructions Manual;
- Warranty card with warranty conditions;
- Bracket for the sign "Slow-moving vehicle";
- The two-line pneumatic brakes with adjustable braking force (single-line system is available on request);
- Parking brake;
- Lighting installation;
- Semi-elliptic spring suspension;
- Folded walls, front and rear.

On customer's request (additional costs incurred), the manufacturer may equip the trailer with the Slow-Moving Vehicle sign and a reflective warning triangle.



CE DECLARATION OF CONFORMITY



FOR THE MACHINE

METAL-FACH Sp. z o.o.
ul. Kresowa 62
16-100 SOKÓŁKA

acting as the manufacturer

declares under sole responsibility that the following machine:

FARMING PLATFORM TRAILER

type/model: T009

serial number:

year of manufacture:.....

this declaration concerns, meets the following requirements:

- Directive 2006/42/EC OF THE EUROPEAN PARLIAMENT AND OF THE COUNCIL dated May 17th, 2006 on machines and the Resolution of the Minister of Economy of October 21st, 2008 concerning general requirements for machinery (Journal of Laws, issue 199 item 1228);

The following harmonised standards were used for compliance evaluation:

PN-EN 1853+A1:2009E	PN-EN ISO 13857:2010P
PN EN ISO 4254-1:2013	PN-EN ISO 12100:2012P

- and the following standards: PN-ISO 3600:1998, PN-ISO 11684:1998; and the Resolution of the Ministry of Infrastructure of 31 December 2002 on technical requirements for vehicles and the scope of their necessary equipment (Journal of Laws 2003, no. 32 item 262 as amended).

Safety Test Report No. MF/1/2010; LBC/29/12

Unit responsible for engineering documentation: Metal-Fach Engineering Department

This Declaration of Conformity becomes void and null if the machine design is changed or modified in any manner without prior consent from the manufacturer.

Sokołka.....

President of the Managing Board

Jacek Marek Kucharewicz

CE DECLARATION OF CONFORMITY

 FOR THE MACHINE

METAL-FACH Sp. z o.o.
ul. Kresowa 62
16-100 SOKÓŁKA
acting as the manufacturer

declares under sole responsibility that the following machine:

FARMING PLATFORM TRAILER

type/model: T014/1; T014/2

serial number:

year of manufacture:.....

this declaration concerns, meets the following requirements:

- **Directive 2006/42/EC OF THE EUROPEAN PARLIAMENT AND OF THE COUNCIL** dated May 17th, 2006 on machines and **the Resolution of the Minister of Economy** of October 21st, 2008 concerning general requirements for machinery (Journal of Laws, issue 199 item 1228);

The following harmonised standards were used for compliance evaluation:

PN-EN 1853+A1:2009E	PN-EN ISO 13857:2010P
PN EN ISO 4254-1:2013	PN-EN ISO 12100:2012P

- and the following standards: PN-ISO 3600:1998, PN-ISO 11684:1998; and the Resolution of the Ministry of Infrastructure of 31 December 2002 on technical requirements for vehicles and the scope of their necessary equipment (Journal of Laws 2003, no. 32 item 262 as amended).

Safety Test Report No. MF/1/2010; LBC/29/12

Unit responsible for engineering documentation: Metal-Fach Engineering Department

This Declaration of Conformity becomes void and null if the machine design is changed or modified in any manner without prior consent from the manufacturer.

Sokołka.....

President of the Managing Board

Jacek Marek Kucharewicz



1.3. MACHINE IDENTIFICATION

In all correspondence, questions, and warranty issues, please state the type and identification number of the trailer.

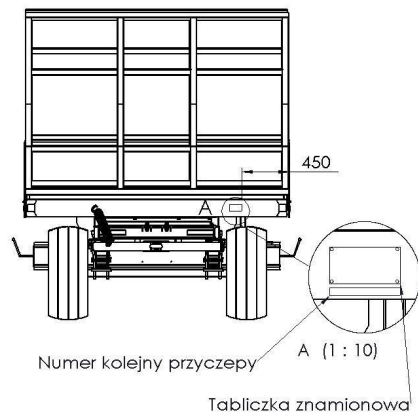

The identification data is found on the trailer nameplate located on the trailer chassis front crosspiece. The trailer serial number is stamped on the nameplate and under the plate, directly on the machine frame.

**THE MANUAL IS A PART OF THE TRAILER'S
ESSENTIAL EQUIPMENT.**



WARNING!



It is forbidden to drive the trailer on public roads or operate the trailer without its nameplate or with an illegible nameplate.

METAL - FACH Sp. z o.o. ul. Kresowa 62 16-100 Sokółka, Poland tel. +48(085)711 98 40 www.metalfach.com.pl				
Typ/Wariant	T009	Masa własna	3560	kg
Data prod.	20			
Nr fabr.	91113xxxxx	KJ	QC	
Nr świadectwa homologacji	PLx4263x02			
Dopuszczalna masa całkowita	15000	kg		
Dopuszczalne obciążenie osi	49	KN		

METAL - FACH Sp. z o.o. ul. Kresowa 62 16-100 Sokółka, Poland tel. +48(085)711 98 40 www.metalfach.com.pl				
Typ/Wariant	T014	Masa własna		kg
Data prod.	20			
Nr fabr.		KJ		
Nr świadectwa homologacji				
Dopuszczalna masa całkowita		kg		
Dopuszczalne obciążenie osi		KN		

2. GENERAL SAFETY RULES

2.1. SYMBOLS AND NOMENCLATURE

 IMPORTANT!	<p>Failure to comply with these guidelines may result in damage of equipment or its components.</p>
 WARNING!	<p>This warning sign in the Operating Instructions means that special caution shall be exercised due to hazards to persons and potential damage to the product.</p>
 ATTENTION!	<p>It is important to carefully follow these notes or guidelines.</p>

Qualified persons are persons who perform the required tasks by always using their education, experience and training, as well as their understanding of standards, definitions, accident prevention regulations and operating conditions; hence they are also capable of identifying and avoiding potential hazards.

Among others, these persons are also required to understand first aid measures for the injured (e.g. by wounding).

The term "operation" includes settings, starting (preparation for use) and operation (starting, commissioning, powering off, etc.).

The term "maintenance of proper condition" includes checks and care (control, adjustments), servicing and repairs (troubleshooting).

Note all other (specially highlighted) indications, such as:

- transport;
- assembly;
- operation;
- servicing;
- technical data (in the Operating Instructions, production records and on the trailer itself).

It is all the same essential due to the potential (direct and indirect) hazards and their consequences being severe damage of human health and property.

2.2. OBLIGATORY NOTIFICATION

When the trailer is transferred to another user, the Operating Instructions shall be transferred as well, whereas the receiving user must undergo training according to the instructions.

2.3. GENERAL SAFETY REGULATIONS ON WORK AND USE

Before each start of work, inspect the trailer for work safety.

1. Aside from the guidelines in these Operating Instructions, follow the general regulations for safety and accident prevention.
2. The affixed information and warning signs and text indicate important guidance for safe operation. Follow it for your own safety.
3. Start the trailer only when all required equipment is connected and secured against unintended release or opening (e.g. the hitch and tow bar system, couplings, etc.).
4. Understand all equipment and controls, as well as their functions, before work. It is too late to learn that during work.
5. The trailer must not be used by persons who are under the influence of alcohol and/or other substances, and/or not trained or suitably licensed to operate motor vehicles.

2.3.1 SAFETY OF OPERATION

1. All work safety information shall be given to all other users of the trailer.
2. Check the direct environment (for children and bystanders) before start. Pay particular attention when visibility is poor.
3. Do not remain on the trailer in motion and when coupling the trailer with a tractor.
4. Enter the trailer only when it has completely stopped and with the tractor engine stopped.
5. Hitch the trailer according to regulations, couple only with recommended equipment and secure the tow bar hitch-ring to the tractor transport hitch.
6. Exercise extreme caution when coupling/decoupling the trailer with/from the tractor.
7. Follow the maximum allowable axle loads, total weight and transport dimensions.
8. Do the following checks: coupling and functional test of brakes and lights, the slow-moving vehicle sign, and other protective devices.
9. Do a functional test of lights and brakes before driving. Also prepare the trailer as recommended in Section "Travelling on public roads".
10. Mind the changes in vehicle behaviour, steerability and braking efficiency due to the hitched trailer and its load.
11. When towing the trailer, mind the layout of loads and/or inertia, especially when the load is unevenly distributed.
12. Bystanders must not enter the work zone of the trailer when it is working.
13. Be careful to avoid crushing of fingers and hands during opening and closing of the trailer walls.
14. Mind the warnings of crush and cut hazard areas when starting the trailer to work. There is a risk of injury when coupling/decoupling the trailer with/from the tractor. When coupling/decoupling, do not enter between the trailer and the tractor or stand behind the trailer if the trailer is not secured with wheel chocks or the parking brake.
15. No person is allowed to remain between the trailer and the tractor if the vehicle is not secure from rolling by the parking brake and/or wheel chocks.
16. When parked, secure the tractor and the trailer against rolling.
17. Couple the trailer with the tractor by the upper hitch only.
18. Follow the permitted maximum vertical and horizontal load of the trailer.
19. Always adapt your driving speed to the conditions. Avoid rapid turns when driving uphill or downhill.
20. Maintain safe distance from the U-turn range of the trailer.
21. When driving in reverse is necessary, ensure adequate visibility (with the help of a signalling person, if necessary).
22. When cornering, mind the inertia of the trailer and its load.
23. Secure the transported load on the trailer (with chains, tarpaulin, plastic sheet, nets, transport straps, etc.) only with tractor engine off and the ignition key removed.
24. Remove functional disturbances of attachments only with the engine turned off and the ignition key removed. Remove functional disturbances of attachments only with the engine turned off and the ignition key removed.
25. Enter the load surface only after turning off the drive and stopping the tractor engine. Remove the ignition key.
26. Before exiting the tractor, always turn off the engine and remove the ignition key. Engage the parking brake and secure the trailer with wheel chocks.
27. When travelling on public roads, the permissible axle load of the T009 / T014/1 / T014/2 trailer must not exceed 49 kN / 47.48 kN / 56.9 kN on the front axle and 98 kN on the multiple rear axle (49 kN per each axle) / 50.52 kN / 56.9 kN on the rear axle, respectively.
28. The maximum permissible pneumatic pressure of the two-line system is 0.8 MPa [0.6 MPa for the single-line system].
29. Prepare the trailer for work (connect the pneumatic lines, etc.) with the tractor engine off and the ignition key removed.
30. The manufacturer delivers the trailer completely assembled.

2.3.2. TYRES

1. Make sure to secure the trailer against accidental movement when servicing the tyres.
2. The wheels and tyres shall be repaired by trained personnel with adequate tools.
3. Regularly check the tyre pressure. Maintain the recommended pressure values.
4. Protect the tyres against sunlight during prolonged parking of the trailer.
5. Replace the wheels with the trailer empty, if possible.

2.3.3. PNEUMATIC SYSTEM

1. The pneumatic system is under high pressure.
2. When connecting the pneumatic lines with the pneumatic system of the tractor, ensure that the valves on the tractor and the trailer are depressurised.
3. Periodically inspect the pneumatic connections. Replace all damaged and aged parts immediately. Replace the lines as recommended in the manufacturer's technical requirements. Replace hoses every 5 (five) years unless damage is found earlier.
4. Before attempting any work on the pneumatic system, depressurise it and turn off the tractor engine.
5. All repair work on the pneumatic system may only be performed by specialist services of the trailer's manufacturer.

2.3.4. PERIODIC MAINTENANCE

1. All maintenance, repair and cleaning operations, as well as troubleshooting must be performed after turning the drive and the tractor engine off. Remove the ignition key.
2. Inspect all bolts and nuts periodically and retighten if necessary. Replace regular bolts only with the bolts of the same quality and strength ratings.
3. Use proper tools and safety gloves when replacing any parts.
4. After completing your work, thoroughly clean the trailer to leave no remains of the load on the body.
5. Before arc welding and/or working on the electrical system, isolate the continuous electrical power supply.
6. The safety/protection equipment wears out, which requires periodic adjustments, inspection and replacement when necessary.
7. Use only the original spare parts recommended by METAL-FACH Sp. z o.o. Sokółka.
8. Store the trailer in sheltered areas (preferably on level and hardened ground) and in a manner which prevents injuries of people and animals.
9. Release all worn out parts to authorised recycling points while following all applicable environmental protection requirements.

2.3.5. TRAVELLING ON PUBLIC ROADS





Before driving, check that the trailer lighting is working and that the trailer identification is complete.

Follow the traffic code regulations when travelling on public roads.

1. Exceeding the permissible payload and driving speed may damage the trailer and compromise traffic safety.
2. Do not exceed the permissible driving speed of 40 km/h.
3. The trailer is designed for operation at grades of 8° maximum.
4. When travelling on public roads, the trailer must feature a reflective warning triangle, and the slow-moving vehicle sign in the trailer bracket located on the chassis frame rear crosspiece (included with the trailer).
5. Do not leave the loaded trailer on slopes and when it is not secured against rolling. Secure the trailer by engaging the parking brake and chocking the wheels. Also bind the transported load with transport straps.

2.3.6 WARNING/INFORMATION SIGNS AND TEXT ON THE TRAILER

The warning signs and messages on the trailer must not be removed. They indicate the possible hazards of operating the trailer. If any information label is damaged or removed, order a spare one. Text and symbol label stickers are available from service agents or the trailer's manufacturer.

No.	Safety symbol (sign)	Meaning of the symbol (sign) or text	Location on the machine
1.		Read the Manual	On the chassis front crosspiece
2.		Turn off the engine and remove the ignition key before servicing or repairs	On the chassis front crosspiece
3.		Keep a safe distance from power lines	On the chassis front crosspiece
4.		Do not reach into the crushing area if the parts may move	At the trailer walls
5.		Do not ride on the machine – use the passenger seat only	On the chassis front crosspiece

6.		Lifting point	On the chassis frame side members
7.	Warning text on the trailer	"Couple with the tractor upper hitch only"	On the chassis front crosspiece
8.		Caution! Do not enter the trailer when it is hauled	On the chassis front crosspiece
9.		"Load capacity 11.4 t" - T009 "Load capacity 9 t" - T014/2 "Load capacity 7.4 t" - T014/1	On the chassis frame side members
10.		Maximum pneumatic system pressure: 0.8 MPa, two-line system 0.6 MPa, single-line system	On the floor front crosspiece
11.	Tyre pressure	"350 KPa" - Mitas tyres "360 KPa" - Starco tyres "480 KPa" - Trelleborg tyres	Over the wheels

	<p>The trailer user is required to keep the warning symbols and text on the trailer legible during its entire operating life. If damaged or destroyed, replace with new ones.</p>
ATTENTION!	

3. TECHNICAL CHARACTERISTICS, GENERAL DATA

No.	Content			
I General data				
1.	Vehicle type	farming truck trailer for bales		
2.	Manufacturer:	METAL-FACH Sp. z o.o. 16-100 Sokółka, ul. Kresowa 62		
3.	Type (model)	T009/T014		
4.	Body type	platform		
5.	Nameplate location	chassis frame front crosspiece		
6.	S/N stamping location	on the nameplate and underneath		
II Dimensions and weight				
		T009	T014/1	T014/2
7.	Length, mm	11900	9750	7020-9750
8.	Width, mm	2485	2520	2520
9.	Height, mm	2600 - 3000, depending on the location of the front and rear walls		2900-2940
10.	Number of axles, pcs.	3 (single front axle, rear tandem axle)	2	2
11.	Wheel track, mm	1700	1700	1700
12.	Wheel base, mm	5485; tandem axle wheel base 1125	3950	3950
13.	Front overhang, mm	1340	1340	1340

14.	Rear overhang, mm	2900	2900	2900
15. Loading room size				
	- length, mm	9700	6540-7270	6540-7270
	- width, mm	2485	2520	2480
	- height, mm	1875	1875	1750
16.	Loading surface height, mm	1125	1025	1025
17.	Tow bar oscillation height, mm	870	830	830-870
18.	Tow bar hitch-ring diameter, mm	40	40	40
19.	Vehicle ramp clearance, mm	355	370	380-410
20.	Vehicle kerb weight, kg	3560	2600	2600
21.	Permissible vehicle overall weight, kg	15000	10000	11600
	- front axle, kg	5000	4850	5800
	- rear axle, kg	10000 (5000 kg per each tandem axle)	5150	5800
22.	Maximum axle load, kN			
	- front, kN	49	47.58	56.9
	- rear, kN	98 (49 kN per each tandem axle)	50.52	56.9
23.	Permissible load capacity, kg	11440	7400	9000

III Suspension										
24.	Suspension type	dependent, with springs			dependent, with springs			dependent, with springs		
25.	Spring component type and style	7-leaf semi-elliptic spring with stop			7-leaf parabolic spring with stop			7-leaf parabolic spring with stop		
IV Wheels and tyres										
26.	Number of wheels, pcs.	6			4					
27.	Wheel disk size	13.00x15.5		16.00x17	13.00x15.5			16.00x17		
28.	Tyre size and PR number	400/60-15.5 14PR 145A8 or 400/60-15.5 14PR 140A8		500/50-17 PR14 149A8	400/60-15.5 14PR 145A8			500/60-17 14PR 149A8		
	tyre manufacturer	Mitas	Starco	Trelleborg	Mitas	Starco	Trelleborg	Mitas	Starco	Trelleborg
V Braking system										
29.	Service brake									
	- type	mechanical, drum-type			mechanical, drum-type			mechanical, drum-type		
	- control	pneumatic, positive pressure, two-line system (single-line or hydraulic system available on request)			pneumatic, positive pressure, two-line system (single-line system available on request)			pneumatic, positive pressure, two-line system (single-line system available on request)		
	- no. of wheels operated	6			4			4		
30.	Parking brake									
	- type	mechanical, drum-type			mechanical, drum-type			mechanical, drum-type		
	- control	manual, by a screw gear			manual, by a screw gear			manual, by a screw gear		
	- operated components	4 wheels of the rear tandem axle			2 rear axle wheels			2 rear axle wheels		

VI Electrical system				
29.	Voltage rating, V	12 V, feed by the driving tractor	12 V, feed by the driving tractor	12 V, feed by the driving tractor
VII Operating data				
30.	Maximum speed, km/h	40	40	40
31.	Maximum transport speed, km/h	30	30	30
32.	Minimum U-turn diameter, left/right, mm	8555	11180	11180
VIII Additional Information				
33.	Other information:			
	tractor hitch coupling	upper transport hitch	upper transport hitch	upper transport hitch
	driving tractor	50 kW minimum	40 kW minimum	40 kW minimum

4. GENERAL DESCRIPTION OF DESIGN AND FUNCTION

The T009 (T014) trailer is a metal structure with open load surface. The trailer features a pneumatic service brake and a parking brake that is manually operated via a screw gear, actuating the friction components of the rear axle service brake.

The trailer features a complete signalling and warning system (an electrical system and reflective lights).

The trailer is also suitable for transport on public roads.

The trailer is manufactured in accordance with:

- Directive 2006/42/EC
- and the following standards:
- PN-EN ISO 12100:2012P
- PN EN ISO 13857:2010P
- PN-EN ISO 1853+A1:2009E
- PN-EN ISO 4254-1:2013

4.1. CHASSIS

The trailer chassis is composed of the following subassemblies: bottom frame, turntable frame, turntable, tow bar, wheel sets and suspension components. The bottom frame, the turntable frame and the tow bar are welded structures made of steel sheet and profiles.

The trailer wheel sets are composed of: the axles (front and rear), land wheels and wheel brakes.

The axles are made of thick-wall pipes terminated with plugs on which land wheel hubs are set by cone bearings. They are single wheels equipped with drum brakes with the shoes actuated by mechanical expander cams.

The trailer axle suspension consists of steel semi-elliptic leaf springs attached to the turntable frame and the bottom frame by pins and sliders. The wheel sets are attached to the springs by bolts.

4.2. LOADING SPACE

The loading surface is made of the bottom frame with a steel floor welded to it, and the walls (the front wall and the rear extended wall).

4.3. ELECTRICAL SYSTEM (SIGNALLING AND WARNING)

The trailer electrical system is designed for 12 V DC supply from the driving tractor system.

The diagram of the electrical system and the trailer lights layout are shown in fig. 1.

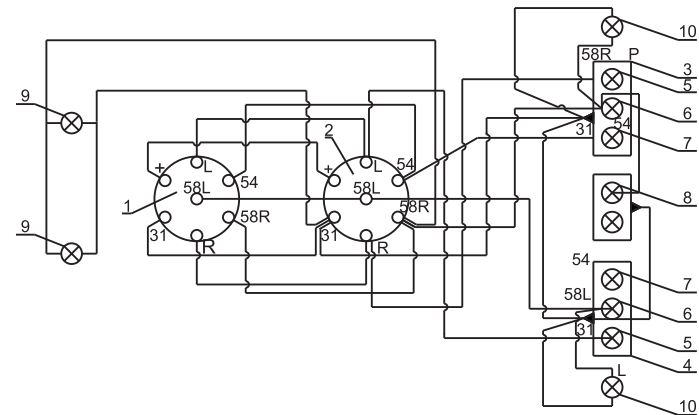

Fig. 1. Trailer's electrical system diagram
 1 - 7-pin plug; 2 - 7-pin socket; 3 - right tail cluster lamp; 4 - left tail cluster lamp; 5 - turn indicator light bulbs; 6 - tail parking light bulbs; 7 - stop light bulbs; 8 - registration plate light bulbs; 9 - front parking light bulb; 10 - outline marker lamp.

4.4. BRAKING SYSTEM

The T009/T014 trailer is equipped with the following braking systems:

- service brake: pneumatically actuated, two-line system (or single-line on request), operates all wheels, controlled from the driver's seat by pressing the tractor's brake pedal;
- parking brake: mechanically controlled by hand via a crank lever mechanism and a screw gear, located on the left side of the trailer and operating the rear tandem axle wheels.

The service brake design ensures automatic braking of trailer land wheels if the pneumatic system is accidentally decoupled between the trailer and the tractor.

The single-line and double line pneumatic system diagrams are shown in the following figures.

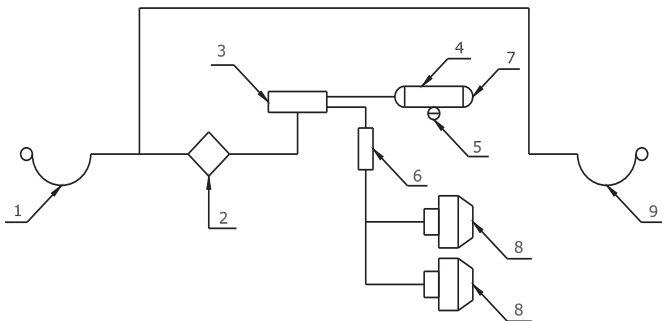

Fig. 2 Single line pneumatic system diagram
1 - 1st trailer pneumatic connector; 2 - air filter; 3 - control valve; 4 - air tank; 5 - water drain valve; 6 - manual braking force control; 7 - check connector; 8 - pneumatic membrane actuator; 9 - 2nd trailer pneumatic connector.

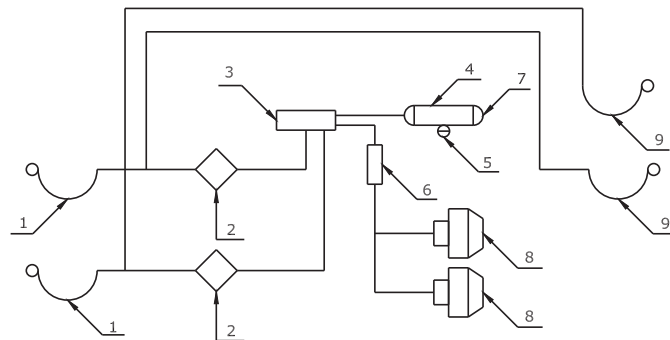

Fig. 3 Two-line pneumatic system diagram
1 - 1st trailer pneumatic connector; 2 - air filter; 3 - control valve; 4 - air tank; 5 - water drain valve; 6 - manual braking force control; 7 - check connector; 8 - pneumatic cylinder; 9 - 2nd trailer pneumatic connector.

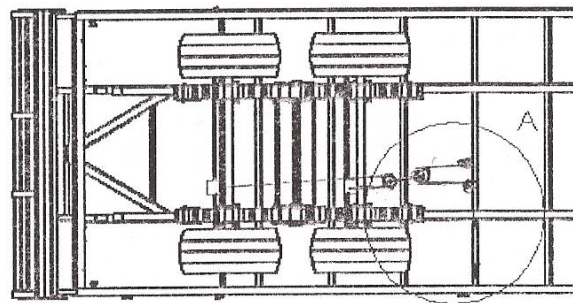

Fig. 4. Parking brake diagram

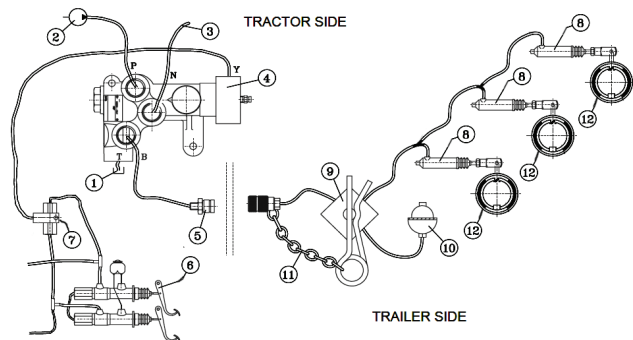

Fig. 5. Diagram of the hydraulic braking system:
TRACTOR END

1. oil return tank
2. hydraulic system feed pump
3. oil return line to tractor cycle
4. pressure signal from the brake pump
5. hydraulic quick-release coupling
6. tractor brake lever
7. manifold tee

TRAILER END

8. hydraulic brake actuator, French type 303061_P35
9. safety valve, Ro 15508
10. hydraulic accumulator, 0.75 11800064
11. chain
12. drum brake

When servicing the trailer, check the tightness and the condition of parts and connections of the braking system.

Check the leak-tightness of the system at the rated pressure (100 bar). Leaks will be indicated by oil flowing outside. If the leaks is caused by damaged seals, lines or other parts [e.g. valves, cylinders, etc.], replace the defective components.

4.5. BRAKES - OPERATING PRINCIPLE

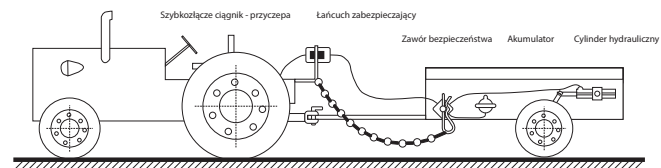

1. The hydraulic system can be decoupled at the quick-release coupling without any damage.
2. When the safety chain is tensioned, it switches over the safety valve to the braking system engaged mode.

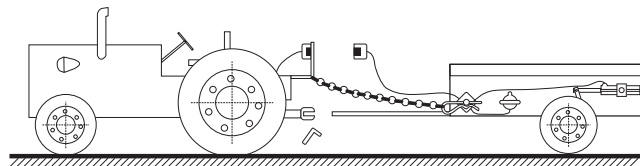

1. The trailer brake is engaged by the pressure in the accumulator.
2. The tractor is decoupled from the trailer and the quick-release coupling prevents the oil from escaping.

3. The braking system does not suffer from any damage and it can be recoupled with full functionality at any time.

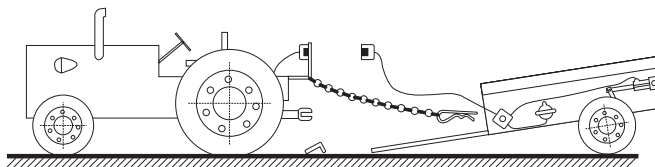

5. STORAGE, SALE AND SHIPPING TO USER

5.1. STORAGE

- Protect the trailer against direct exposure to sunlight and rain. Park it with its land wheels chocked on a hard-paved ground (reduce tyre pressure and cover the tyres if there is a risk of exposure to sunlight).
- If the trailer is exposed to weather, periodically check for rainwater accumulation in the trailer. Note all damage to the paint coat. Clean and degrease spots of damaged paint. Next, repaint with the same colour and coat thickness.
- Long-term storage is recommended in sheltered rooms only.

5.2. SALE

- The buyer collects the trailer from the manufacturer or the sales representative on their own, or arranges the delivery with the manufacturer.
- The trailer is sold as fully assembled and ready for operation, complete with the basic equipment listed in this Manual. Optional equipment is available for extra charge.
- The sales representative personnel is required to introduce the buyer to the design and operation of the trailer, along with safety requirements and warranty conditions.
- The buyer shall verify the following:
 - The trailer is complete, undamaged and with all basic equipment;
 - the nameplate located on the chassis front crosspiece has the serial number stamped that matches the data in the warranty card;
 - the warranty card has been properly filled out with the identification data on the nameplate.

5.3. SHIPPING TO USER

The trailer shall be transported from the sales representative on wheels as coupled with a tractor or on a low-bed trailer. Before loading on a low-bed trailer, connect the farming trailer with the transport hitch and the braking lines of the tractor. Place the farming trailer on the low-bed trailer using the extended ramps. Next, secure the farm trailer with wheel chocks. Afterwards, disconnect the braking system and decouple from the tractor. Secure the farming trailer with special transport straps.

Before unloading the transported trailer, extend the low-bed trailer ramps and release the transport straps used to secure the farming trailer from falling down in transit.

Approach with a tractor and connect the trailer braking system's cables. Next, remove the chocks from underneath the trailer's wheels. When all of the above has been completed, unload the trailer from the carrier vehicle.

6. OPERATION INFORMATION

6.1. COMMISSIONING THE TRAILER



IMPORTANT!

*Use only tractors that are fit for service (with the transport hitch, the pneumatic system and the signalling/warning system working)

Do the following before commissioning the trailer:

- Understand the names and locations of individual assemblies/components of the trailer;
- check the tyre pressure;
- couple the trailer with the tractor:
 - set the tow bar hitch-ring of the trailer at the trailer transport hitch height;
 - couple the hitch-ring with the trailer hitch;
 - secure the hitch pin against falling out;
 - turn off the tractor's engine;
 - engage the tractor's parking brake;
 - connect the appropriate sockets and plugs of the pneumatic and electrical systems;
- do the functional checks of the electrical, pneumatic and hydraulic systems of the tractor and of the trailer, and check leak tightness of the hydraulic and pneumatic systems on both vehicles;
- check all equipment, the connections and safety from accidental release or misalignment;
- release the trailer's parking brake.

Perform all these actions each time before working with the trailer.



ATTENTION!

Couple the trailer with the tractor's upper hitch only. No bystanders shall remain between the trailer and the tractor when the two are being coupled.

6.2. LOADING THE PLATFORM

Load the platform only when the trailer is coupled with the tractor and parked on level ground. Both vehicles must have brakes engaged.

Use mechanical loading equipment (cranes, loaders, conveyors, etc.) to load the trailer.

Spread the load evenly across the entire load floor surface. If loading with machines, ensure that the load is gently lowered on the platform floor.



ATTENTION!

- Do not exceed the permissible payload and permissible axle loads, otherwise the trailer can be damaged and the traffic safety compromised.
- * The transported load shall be secured from shifting with straps [recommended method].

6.3. TRAVELLING ON PUBLIC ROADS

Before entering a public road, do the actions listed in section 6.1 and also the following:

- Install the slow-moving vehicle sign on the trailer;
- Ensure that the transported load is secured with straps from falling down on the road;
- Check that the load does not exceed the permissible capacity or axle load.



ATTENTION!

- Follow the traffic code regulations.
- * In the first operating hours of the brakes, the drum brake shoes align themselves with the drums. The full braking effectiveness is achieved once the friction parts have run in.



B (1 : 5)
Uchwyt dla tablicy
wyróżniającej pojazdy
wolnonuruszające się

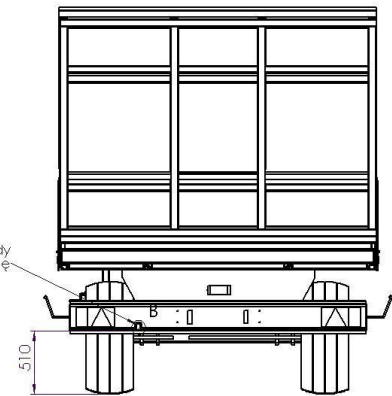

Fig. 6. Location of the bracket for the slow-moving vehicle sign

6.4. UNLOADING

Unload the trailer by mechanical means (cranes, loaders, conveyors, etc.). The trailer shall stand on level ground and be coupled with the tractor (whenever possible).

Before unloading, make sure that no person is near the platform.

6.5. DECOUPLING FROM THE TRACTOR

Do the following actions to decouple the trailer from the tractor:

- Stop the tractor with the trailer at the location where the latter will be left, and engage the tractor's parking brake;
- Engage the trailer's parking brake;
- If the trailer stands on uneven or sloping ground, secure it from rolling down by chocking the wheels;
- Disconnect the electrical and pneumatic lines from the tractor;
- Remove the safety from the hitch pin and then remove the pin – this will decouple the tow bar from the hitch;
- Drive the tractor away from the trailer and reinstall the hitch pin.



ATTENTION!

- * Do not decouple the trailer from the tractor if the trailer is not secured against rolling away.

7. SERVICING

7.1. SERVICING INSTRUCTION FOR ADJUSTABLE TRAILER COMPONENTS

In order to maintain proper performance, the T009 (T014) trailer requires the following adjustments:

- Adjustment of the wheel bearing clearance;
- Adjustment of the braking system components.

7.1.1. WHEELS – BEARING CLEARANCE ADJUSTMENT

During the first operating hours of a newly purchased trailer (i.e. after approximately 100 km of mileage) and further operation (i.e. after the next 1500 or 2000 km), check the wheel bearing clearance and adjust, if necessary.

To do so:

- Couple the trailer with the tractor and engage the tractor's parking brake.
- Jack up one side of the trailer to lift the wheel from the ground on this side and secure it against falling.
- If the wheel has excessive clearance, remove the hub cap and remove the crown nut clevis pin.
- Rotate the wheel and tighten the crown nut at the same time until the wheel stops turning.
- Loosen the crown nut by 1/6 to 1/3 of the full turn, i.e. until the nearest clevis pin groove is aligned with the hub pivot hole.
- Secure the nut with a new clevis pin, and reinstall and retighten the hub cap.

After a correct adjustment of bearing clearance, the wheel should rotate smoothly, without cogging or evident resistance (not caused by rubbing of the brake shoes against the drum). Slight rubbing of the shoes against the drum, especially on a brand new trailer or following replacement of the shoes is normal. Do the final check of proper bearing clearance adjustment

by travelling several kilometres and inspecting the hub heating by hand. Apart from incorrect clearance adjustment, significant rolling resistance of the wheels and heating of the hubs can also be caused by contaminants in the grease or damage of bearings. These symptoms require removal of the wheel hub to be corrected, if found.



ATTENTION!

Follow these rules when jacking up the trailer wheel:

- Couple the trailer with the tractor, move to level ground and engage the tractor's parking brake;
- Chock the wheel that is not being jacked up;
- Place the jack under the axis and near the jacked up wheel, and lift the wheel so that it clears the ground;
- Secure the wheel against falling by putting a prop of suitable height under the axis.

7.2. BRAKES

When servicing the trailer, check the tightness and the condition of parts and connections of the braking system, and periodically drain the water condensate from the air tank.

Check the leak tightness of the system at the rated pressure of approx. 800 kPa for the two-line system. Leaks are detected by a distinct hiss or air bubbles (after coating with soapy water) at the points of air escape from the system. If the leaks are caused by damaged seals, lines or other parts (valves, actuators, etc.), replace them.

Drain the water from the air tank by tilting the drain valve stem to the side when the tank is pressurised; the drain valve must also be unscrewed from the tank and cleaned of accumulated dirt once a year, before the winter season.

7.2.1. ADJUSTMENT OF THE BRAKING SYSTEM COMPONENTS.

When servicing the trailer, check the condition of parts and connections of the braking system, and periodically inspect the lubrication of control elements.

Adjust the brakes when the following occurs:

- there is an excessive clearance between the shoes and the drum from the brake shoe wear, resulting in decreased braking performance;
- the wheel brakes work unevenly and out of sync.

With the properly adjusted brakes, the braking force (i.e. the total of braking forces at the circumference of the wheels) shall be at least 27% of the permissible total weight of the trailer when decelerating with the service brake; the braking force (i.e. the total of braking forces at the circumference of the wheels) when actuating the parking brake shall be at least 16% of the permissible total weight of the trailer. Both wheels on the same axle should be stopped evenly; the brake force differential between the left and right trailer side shall not exceed 30%, with 100% being the higher force.

Adjust the brakes by changing the expander lever position against the shoe expander shaft. To do this, jack up the wheel and while turning the wheel, realign the expander lever against the shaft (on the comb) to feel that the brake shoes slightly rub against the drum.

After the correct adjustment of friction components, the wheel should rotate smoothly, without cogging or evident resistance (other than caused by rubbing of the brake shoes against the drum). Slight rub of the shoes against the drum, especially on a brand new trailer or following replacement of the shoes is normal.

After completing the adjustment, check and adjust the parking brake. The parking brake is adjusted by setting the cable length that couples the expander shaft lever with the engaging mechanism. The required sum of braking forces should be produced at the maximum force applied to the hand crank of 40 daN (at the right angle between the cable and the expander shaft lever).

	Before driving, periodically inspect all braking components for proper operation, tightness and clearance. Adjust or repair as necessary.
ATTENTION!	

	Inspect the brake shoes at least each year. Replace worn shoes. In order to achieve the required braking performance after replacement of friction components, remember to run them in (by driving with frequent braking), which should be followed by readjustment.
IMPORTANT!	

7.3. WHEELS – TYRES

Servicing of the tyres involves checking their condition visually and checking the tyre pressure. It is also essential to check that the tyres have no cracks that expose or damage the carcass, and that the hubs, wheel disks and their fastening are in good condition.

	<ul style="list-style-type: none"> • Periodically inspect the wheel nuts (i.e. the condition and tightness before each use of the trailer); retighten if necessary. • Periodically inspect the wheel nuts (i.e. the condition and tightness before each use of the trailer); retighten if necessary. • Nut tightening torques for different thread sizes: <ul style="list-style-type: none"> • M18x1.5 = 270 Nm. • M20x1.5 = 350 Nm. • M22x1.5 = 475 Nm.
ATTENTION!	

	<ul style="list-style-type: none"> • After the first travels with loads and after each 100 km, inspect the tightness of wheel nuts and retighten if necessary. • Check the tyre pressure. The tyre pressure rating displayed near the trailer wheels applies to transport at the maximum permissible speed (at the maximum payload).
IMPORTANT!	

8. TROUBLESHOOTING

	Fault type	Reason	Remedy
1.	Excessive heating of brake drums	Brake shoes are out of adjustment	Adjust per Section 7.2.1.
2.	Excessive heating of wheel hubs	Insufficient clearing of bearings. Contamination in bearing grease	Adjust per Section 7.1.1. Remove the hub, replace the grease and adjust the bearings as indicated above.
3.	The grease flows out on the brake shoes	Damaged, worn out or improperly installed hub seal	Remove the hub, replace the worn/damaged seal and reinstall properly. Remove the grease from shoes and brakes, clean the friction components with extraction naphtha, reinstall the hub and adjust the bearings as indicated above.
4.	Uneven braking of wheels	Contamination or excessive wear of shoe pads, or the brake shoes are out of adjustment.	Check the brake shoe pads, remove contaminants, replace worn out pads and readjust as in section 7.2.1.

5.	Insufficient wheel braking performance.	Incorrect adjustment of the shoes and brake controls.	Adjust the brake shoes and control components per Section 7.2.1.
----	---	---	--

9. PERIODIC MAINTENANCE

9.1. LUBRICATION

Lubrication is one of the most critical factors that condition good performance of individual assemblies and mechanisms of the trailer.

Daily lubrication applies only to the days during which the trailer is operated.

Follow these rules when lubricating:

- clean the grease nipple before feeding the grease;
- feed the lubricant until fresh lubricant comes out of the gaps (through which the used lubricant is pushed out first);
- when finishing the lubrication, leave some lubricant on the nipple head.

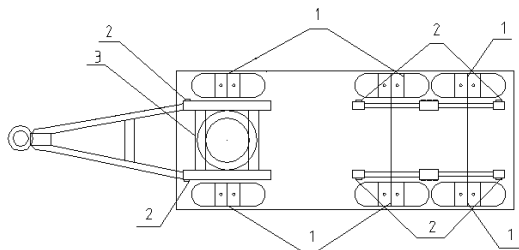

Fig. 7. Mower bar oil level check Lubrication points of the trailer

Lubrication point no.	Lubrication point	Lubricant grade	Lubrication frequency
1.	Wheel hub bearings	LT 43	Once a year
2.	Spring slides	LT 43	Once a year
3.	Turntable	LT 43	Once a year

Other lubrication points

- Spring pins
 - Regularly lubricate movable parts of hinges and articulated joints;
 - Pressure-feed the lubricant with a lubricating gun through clean nipples;
 - Regularly lubricate movable parts of brakes (levers and pins);
 - Lubricate the brake shoe axes only when necessary and only with a small amount of lubricant
- Hub bearings:
- inspect the lubrication of wheel hub bearings each year; add or replace the bearing lubricant;
 - when replacing the lubricant, remove the hub, remove the used lubricant, inspect the bearings' condition (replace with new ones if necessary); after applying the fresh lubricant, adjust the bearing play.

9.2. MAINTENANCE AND SERVICING

The transport capacity and long operating life of the trailer can only be assured if the machine is properly and reasonably operated within its design and functional capacities.

Even a slight negligence in operation may result in severe consequences. A timely discovered fault is easy to remove at a minimum cost and effort, while producing the maximum effect.

Faults of the trailer can only be discovered soon if regular, periodic cleaning and thorough inspection is carried out.

Hence clean the trailer frequently to observe any damage and faults. Also carry out periodic technical inspection of the trailer.

Lubricate the trailer according the guidelines for lubrication.

Store the trailer in a sheltered area to protect it from weather conditions and deterioration.

In order to preserve its proper performance, the trailer must be maintained, readily repaired and thoroughly supervised during its operating life. Daily servicing (before work) of the trailer includes a certain minimum of actions, i.e.:

- check the screwed components and their safeguards from accidental release;
- check the play of mechanisms and articulated joints;
- functional checks of mechanisms;
- check and perform lubrication according to the instructions;
- check the tyre pressure;
- functional check of the brake system and the warning and signalling system.

Repair instructions

- Small repairs required by accidental faults must be carried out with care for cleanliness, installation of all parts at their locations and adjustments essential to proper performance of the trailer.
- Small repairs during operation (in the field) shall be done on site by service personnel.
- All parts removed during repairs shall be stored in conditions that protect from dust and other contaminants. Pay particular attention to protection and cleanliness of bearings.
- During field repairs, keep the area clean when reassembling the parts (the parts which fell to the ground shall be washed or at least cleaned of dirt to an extent that permits proper functioning).
- During running and general repairs, follow the engineering rules for disassembly and (re)assembly of parts and subassemblies to ensure proper quality and performance of work.
- Do functional tests of trailer mechanisms after each repair.

10. DISPOSAL OF THE TRAILER

If the user decides to dispose of the trailer, hand over the entire vehicle to the nearest scrap collection point approved by local authorities. The proof of disposal issued by the collection point is essential for de-registration of the trailer. Recycle the parts which remain after repairs or have become obsolete.

11. RESIDUAL RISKS

11.1. DESCRIPTION OF RESIDUAL RISKS

METAL-FACH Sp. z o.o. is liable for the design and build in order to eliminate all hazards, some partial risk is unavoidable in operation of the trailer.

The residual risk stems mostly from improper behaviour of the operator caused by lack of knowledge or attention. The greatest hazards occur during the following forbidden actions:

1. The trailer is operated by minors or persons who are unfamiliar with the Operating Instructions.
2. The trailer is operated by persons who are ill or under the influence of alcohol or other intoxicants.
3. The trailer is used for purposes other than specified in the Operating Instructions.
4. A person is present between the tractor and the trailer with the tractor's engine running.
5. Bystanders, especially children are present near the working trailer.
6. The trailer is cleaned while working.
7. Manipulation of the driving unit on the tractor and the moving elements of the trailer while the machines are working.
8. Checking the trailer's technical condition when it is running.

While presenting the residual risk the trailer is treated as designed according to the state of knowledge at the year of manufacture and maintaining the basic OH&S rules.

11.2. ASSESSMENT OF RESIDUAL RISKS

Follow these guidelines:

1. Always follow the safety regulations described in the Operating Instructions.
2. Read and fully understand the Operating Instructions.
3. Keep your hands out of hazardous spaces.
4. It is forbidden to operate the trailer in the presence of bystanders, this applies in particular to children.
5. Maintenance and repairs of the trailer shall only be performed by trained personnel.
6. The trailer shall only be operated by persons who have been trained in its operation and have familiarised themselves with the Operating Instructions.
7. The trailer is protected against access by children.
Only then can you eliminate the residual risks to people and the environment when using this trailer.



ATTENTION!

The residual risks are present when the listed rules and indications are not followed.

12. WARRANTY CONDITIONS

1. The manufacturer provides a trailer designed and built in compliance with the current standards. The manufacturer guarantees that the supplied trailer is free of manufacturing defects.
2. Metal-Fach Sp. z o.o. provides 12-month warranty service for the trailer starting from the date of first sale, provided the trailer is used for its intended purpose and the recommendations contained in the Manual are followed.
3. The warranty card properly filled in at the Dealership is the confirmation of the manufacturer's warranty; the acceptance of the warranty conditions must be confirmed by the customer's signature.
4. The quality warranty covers the machine defects caused by defective manufacturing, material defects and latent defects.
5. The warranty does not cover the assemblies and parts which are subject to normal wear and tear.
6. The warranty does not cover any mechanical damage or other damage resulting from improper use, improper maintenance or improper adjustment of the trailer.
7. The warranty does not cover any damage resulting from improper storage of the machine.
8. Any unauthorised modifications in the construction of the machine introduced by the user will result in automatic termination of the warranty.
9. The manufacturer shall not be held responsible for any loss, damage or destruction of the product resulting from causes other than defects of the supplied machine.
10. During the warranty period the manufacturer will repair any defects which occurred as a result of the manufacturer's negligence.
11. The warranty repair shall be made within 14 working days of the notification/supply of the trailer to the designated service station or at another time agreed upon by the parties.
12. The warranty is extended by the time required to complete the repair.

13. All repairs which are not covered by the warranty performed by authorised service stations are made at a full cost payable by the user. Before such repairs, the service station will inform the user of the suggested cost, time and scope of the repair.
14. The Customer makes the decision whether to commence a payable repair of the trailer with a warranty valid at the time of repair.



ATTENTION!

Current information about the products available at www.metalfach.com.pl

METAL-FACH

16-100 SOKÓŁKA, POLAND

UL. KRESOWA 62

WARRANTY CARD

FARMING TRUCK TRAILER FOR BALES

T009/T014

The warranty service is provided on behalf of the manufacturer by:

filled out by the seller

Date of manufacture	Date of sale
Serial number	Dealer's signature
Customer's name and surname		
Address		
		
	Customer's signature	

SALES METAL-FACH®

16-100 Sokółka, ul. Kresowa 62
tel.: +48 85 711 07 88, fax: +48 85 711 07 89
handel@metalfach.com.pl

SERVICE METAL-FACH®

16-100 Sokółka, ul. Kresowa 62
tel.: +48 85 711 07 80, fax: +48 85 711 07 93,
serwis@metalfach.com.pl

SPARE PARTS & SHOP METAL-FACH®

16-100 Sokółka, ul. Kresowa 62
tel.: +48 85 711 07 81, fax: +48 85 711 07 93,
sklep.mf@metalfach.com.pl

METAL-FACH®

METAL-FACH SP. Z O. O.; UL. KRESOWA 62; 16-100 SOKÓŁKA