



E-Brake Ultra 50-130T

Press brakes with an E for Electronic

Unfold the future



the future unfolded

Efficiency

The comprehensive solution
for faster production

Ergonomics

Full control of the process
operations with one finger

As the inventor of the electronic press brake, SafanDarley set in motion a world wide Evolution in sheet metal working. Even now, SafanDarley continues to work on innovative ways to raise your efficiency levels.

With SafanDarley, you will be able to operate at the highest possible level from the get-go and benefit from unique innovations and developments, guided by those people who set the standard: the highest possible standard for integrated sheet metal working.



Ecology

Maximum CO2 and oil reduction

Economics

Maximum return on your investment

SafanDarley offers innovative solutions for all varieties of sheet metal working, using game-changing electronic and hydraulic techniques.

SafanDarley unfolds a future in which each sheet metal worker can benefit from opportunities to produce in a more Efficient, Economical, Ergonomical and Ecological way. Complex products, large and smaller product ranges: process optimisation and lean manufacturing with zero defects are a given with SafanDarley, and just-in-time production is guaranteed.

Working with SafanDarley means being able to trust us at our word and knowing we will keep our promises: regarding providing technology that sets the standard in industrial sheet metal working; regarding introducing innovations that actually contribute to maximum operating efficiency; and regarding being a partner that actively contributes high-level ideas and solutions to your problems. SafanDarley will allow you to be ahead of the times and secure your competitive position.

Smart production in the Smart Industry

SafanDarley leads the way to smarter production with its new technology and its Smart Industry. Smart Industry is an approach that allows industrial companies to take up a strong position by making maximum use of the newest information and technological developments. We do so by implementing far-reaching digitalisation and more closely linking equipment, production resources and organisations, which results in a new, better integrated way of production. SafanDarley thus ensures production that is more efficient, more flexible, of higher quality and tailor-made.

Put in more concrete terms, 'smart production' means improvement of your OEE or Overall Equipment Effectiveness. We consider your every need to make sure that our machines fit into your production line perfectly. Our purpose in employing our machines, software, data communication, robotization and human guidance to aid you is to ensure optimization of your manufacturing processes with zero defects.

Improvement of your Overall Equipment Effectiveness is easy once you have SafanDarley as a part of your production process. To put it more concretely, it is hardly rare for companies' OEE to increase by 30%.

SafanDarley enables you to stay ahead of time and safeguard your competitive position.



Fully electric

SafanDarley E-Brake Ultra

The new generation of E-Brake adds important new advantages to the E-Brake technology, which has already proven itself all over the world. The machines in the 50T-130T range are built according to a modular concept that is a new step forward in the efficiency of machine construction. The new design is in line with the design of the larger E-Brakes. The CNC crowning and the dual screen EC20 control are important characteristics. In addition, more options have been added, and the machine can be expanded with a 3D back gauge, EC40 Smart control, and E-Bend L Blue laser angle measurement system.

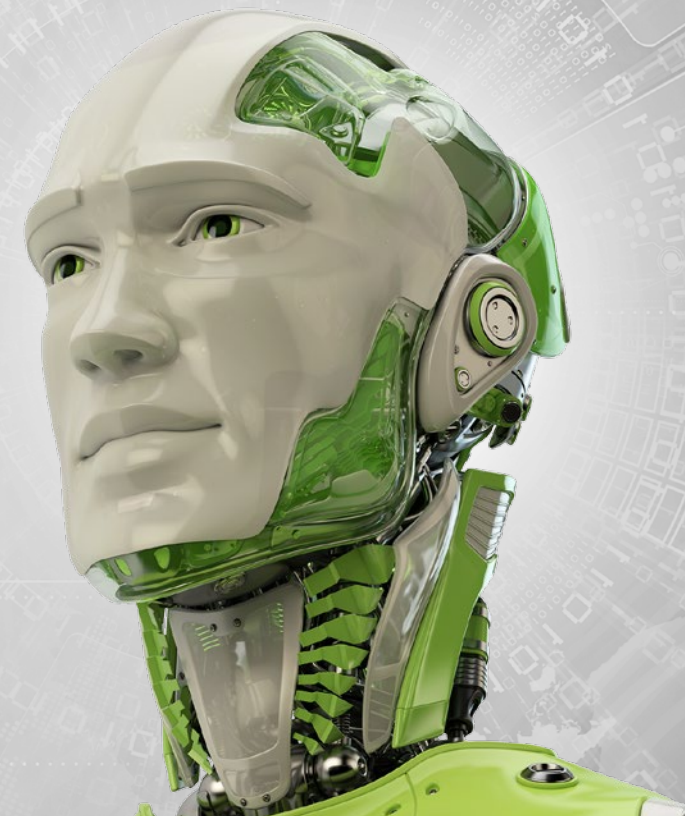

Over 30% higher productivity



Uses up to 50% less energy, less CO2 emission



No harmful hydraulic oil



High degree of noise reduction



Back gauge used across the full working length



User-friendly Touchscreen control

The unique pulley drive of SafanDarley has proven itself around the world

Servo-elektronical bending with the E for even bending

The unique, patented roller drive system in the upper beam ensures a uniform and even distribution of forces. A balanced combination of powerful electro-motors, fixed and movable rollers and specially developed belts facilitate capacities of up to 300T.

The flexible belts, which are only 3 mm thick and 50 mm wide, are reinforced with steel wires and coated with hard polyurethane. This advanced technology has been extensively tested in the demanding elevator industry. So reliable is the technology that SafanDarley are able to offer a 5 year warranty on the mechanical drive system,

when combined with an annual service contract. The special construction of the SafanDarley E-Brake also contributes to the even absorption of large forces. The O-frame acts as a single unit and deformation is kept to an absolute minimum. It is more stable, stronger and produces less deformation than a conventional C-frame.

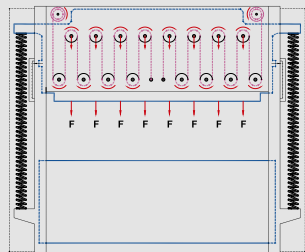

Even distribution of forces

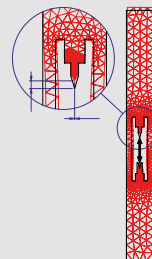

E-Brake

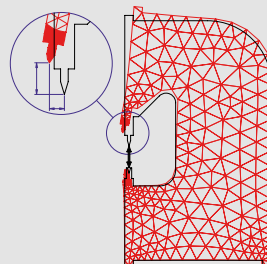

Conventional





E-Brake Ultra

Up to 30% shorter cycle times

The new generation of E-Brake Ultra adds important new advantages to the E-Brake technology, which has already proven itself all over the world. The machines in the 50T-130T range are built according to a modular concept that is a new step forward in the efficiency of machine construction. The new design is in line with the design of the larger E-Brakes. The CNC crowning and the dual screen EC20 control are important characteristics. In addition, more options have been added, and the machine can be expanded with a 3D back gauge, EC40 Smart control, and E-Bend L Blue laser angle measurement system.

The new SafanDarley E-Brake has been optimized further in order to profit from the acceleration options and the other convenient servo characteristics. This not only makes the E-Brake very fast in rapid traverse, but also during the full cycle. This results in incredibly short reaction and stop times, through which bending speeds of up to 20 mm/sec can be achieved. Cycle times are also far shorter than with conventional press brakes, partly through the fast backgauge. In comparison tests, the SafanDarley E-Brake is shown to be up to 30% faster than a conventional press brake. Cycle times for this product (see image below):

SafanDarley E-Brake 50T 2050	Cycle time 20 sec.
Conventional hydraulic press brake	Cycle time 35 sec.

Up to 50% energy saving

The SafanDarley E-Brake only uses energy when the top beam is actually moving. This can deliver an energy saving of up to 50% compared with conventional hydraulic press brakes.

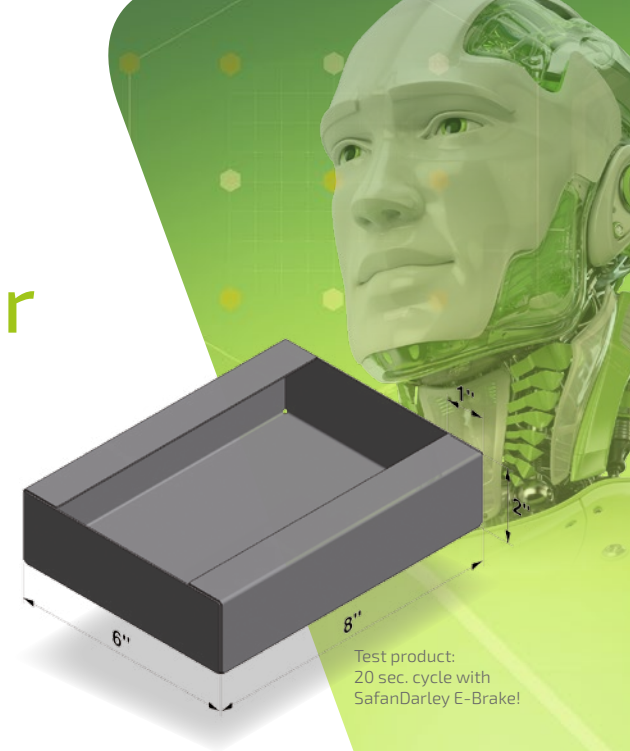

Test product:
20 sec. cycle with
SafanDarley E-Brake!



Bending test product

Innovation

with the E for efficiency

After the success of the first generation of E-Brakes and the breakthrough to the heavier segment of 300 tonnes, we have continued optimizing the machine concept. What could we improve in the construction and how could we make the machine even more efficient to work with? The answer was found in a modular construction of the E-Brake, a new back gauge, and a wider turn.

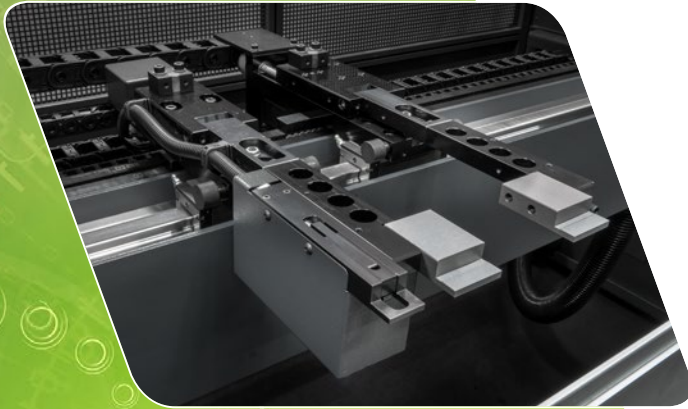

Backgauge with X-, R- and Z1+Z2-axes

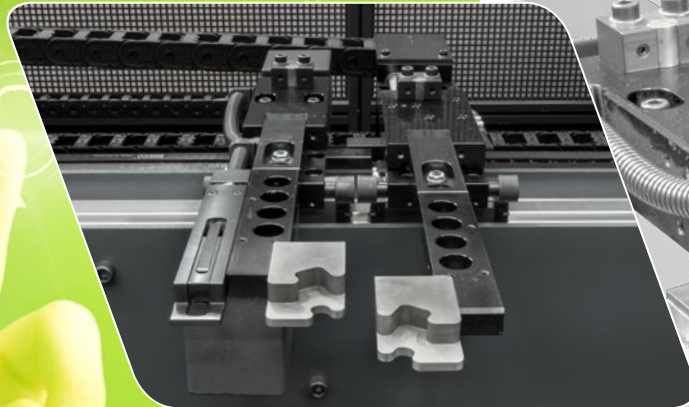

Backgauge with X-, R-, Z1+Z2- and Delta X-axes

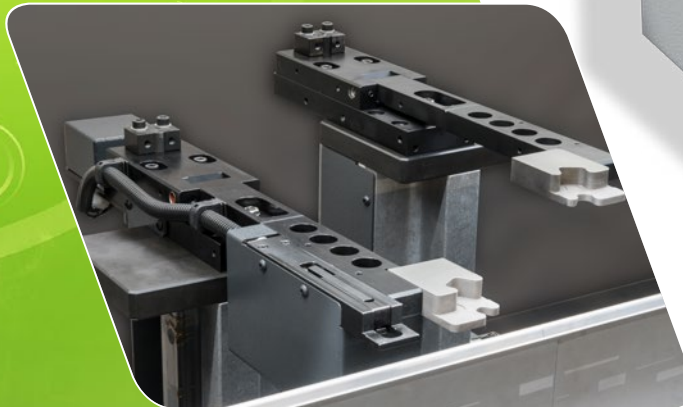

3D backgauge

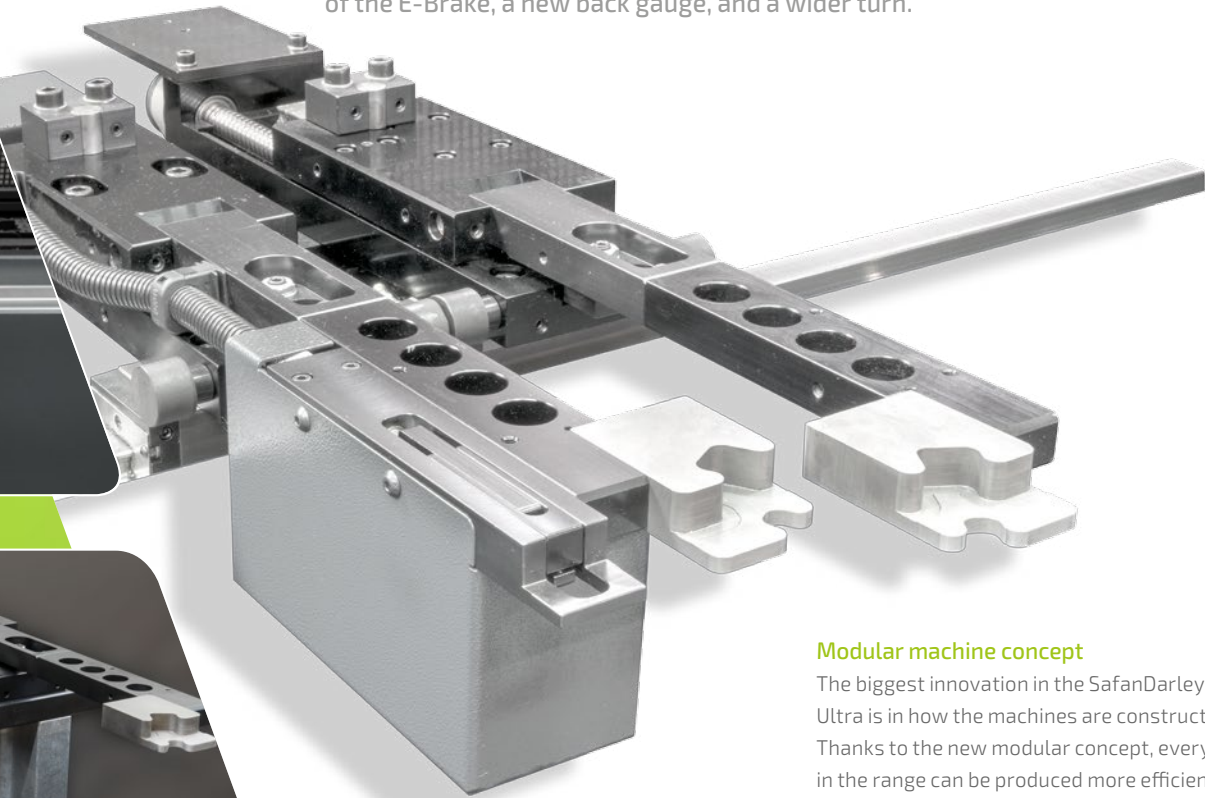

Modular machine concept

The biggest innovation in the SafanDarley E-Brake Ultra is in how the machines are constructed. Thanks to the new modular concept, every machine in the range can be produced more efficiently and delivered faster, from the 35T-1250 to the 130T-3100. The standard Q size (Opening) is 590 mm, but you can opt for 650 mm or 690 mm also.

Extremely stable back gauge with CNC controlled X and R axis

A newly designed construction makes the innovative back gauge system of the SafanDarley E-Brake Ultra extremely stable. The system is very distinct, as the back gauge spans the entire width of the machine. In addition, the electronic control system makes it extremely precise (0.02 mm). The back gauge has a transfer speed of no less than 350 mm/sec. The CNC controlled X and R axes are a standard feature, as are the folding back gauge fingers and 1,000 mm range.

Options

As an option, the back gauge system can be equipped with CNC controlled Z axis and an X axis or a complete 3D back gauge with X1-X2, Z1-Z2, R1-R2 and X axis.

Tool system

As a standard, the E-Brake Ultra comes with the New Standard Premium MC mechanical tool clamp system. As an option, the E-Brake Ultra can be equipped with the New Standard Premium HC hydraulic tool clamp system. Alternatively, you can opt for a European Style clamp system (only in combination with a Q size of 650 mm).

Moveable and adjustable support arms

SafanDarley has developed a range of support arms of modular construction for both light and heavy-duty sheet-metal work. This makes it possible to rapidly set up the correct solution for each application. An optimum combination of ergonomics and efficiency.

All support arms can be used in combination with the light guard. The support arms are as standard equipped with brushes. You can choose from the following possibilities:

- Support arms fixed to the machine
- Support arms movable across the front side of the machine
- Support arms movable across the front side of the machine and height adjustable with a handwheel
- Support arms movable across the front side of the machine and pneumatically adjustable in height (programmable on the control)

Optionally all support arms can be equipped with adjustable front stops



Movable support arms



Movable support arms adjustable in height



Heavy-duty moveable support arms

Programming in three steps

01 Importing and unfolding

The software will automatically determine the correct results, optimum bending sequence, stop positions and optimum tool set-up with as few manipulations as possible based on an imported 3D model. You also have the option of adjusting the bending sequence and stop positions manually.

02 Bending simulation

A complete 3D bending simulation allows you to check the entire bending process. A CNC program containing all of the off-set data will then be generated. This powerful software ensures product-accuracy from the get-go.

03 Production

Retrieving the data package from the network using the controls and get going using the press brake. The NC program and the bending simulation will appear on the bottom screen, and other data such as technical drawings, video, notes, etc. will appear on the top screen (this is optional).

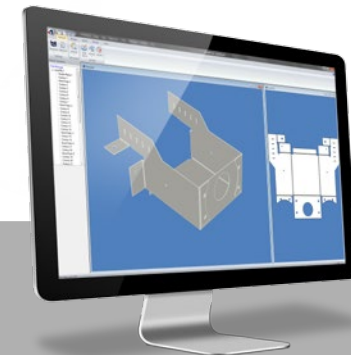

01 Importing and unfolding

Offline 3D-programming

SafanDarley offline 3D programming stands for complete and reliable process management. As opposed to several widely used CAD/CAM systems, our system is very user-friendly and requires only a short 2-day training period.

The design program includes an ingenious simulation and control module for using the press brake that can be remote-controlled, from the office for example. This limits the time during which the machine is at a standstill, thus maximising productivity.

The system consists of 3 simple steps. Fast and flawless work is the SafanDarley standard.

Offline programming offers you plenty of ways to do 3D Design and to import and correctly produce 3D drawings. If the employee using the program is also the one controlling the press brake, an NC code for the system may be generated instantly. The program will then select the necessary tools and optimise the machine. A work planner can even switch to a different press brake at the last moment, re-generate the NC code and run a collision check.

To conclude: optimum streamline of your manufacturing processes. Even when used in conjunction with other CAD and CAM systems.

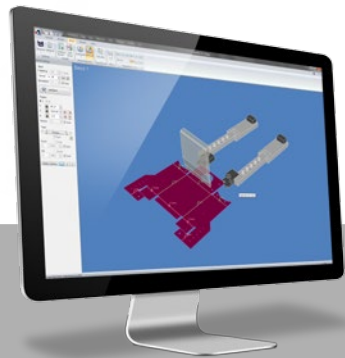

02 Bending simulation



03 Production



SafanDarley E-Control, the new E-standard in ergonomics

Since the introduction in 1995, the SafanDarley E-Controls have been the international standard for ease of operation. The touch screen concept is therefore the most functional and intuitive Man-Machine interface in the sheet-metal working industry. We have once again shifted the standards with the SafanDarley E-Control as the latest generation touch screen controls.

Complete Touch Screen convenience

The SafanDarley E-Control is fully touch screen, whereby the only buttons visible on the 17" screen are those that are needed during operation. The controls simply run on a PC under Microsoft Windows®, the software was developed based on Microsoft.net Framework. The unit is fitted with a 100 MB Ethernet UTP network connection as standard. The instructions are transmitted to a central processor from the SafanDarley E-Control controls, which in turn regulates the various axis via a so-called CAN-BUS (Control Area Network). The system can be programmed quickly and accurately thanks to a 'self-teaching' database with data on materials, tools and previous, already corrected bending. The SafanDarley E-Control can be coupled to the majority of off-line programming systems.

The standard E-Control 20 facilitates both numeric and 2D graphical programming. It is possible to draw a complete product by means of touch screen and to then automatically generate a bending program. The developed length is also calculated. The optional E-Control 30 can be used to generate 3D drawings.

Web-based communication and support

The controls are set-up for web-based communication such as online diagnoses and loading software updates via the web. Machines can also be coupled to each other in a group and tooling databases can be shared. By monitoring and analysing your operating data online, Safan will be in a position to optimise your production process from a distance in the near future.





Summary of EC20, EC30 and EC40 SafanDarley press brake controls

Control type	Possibilities	Off-line connections to
EC20	<p>Numerical product data entry by means of touch screen</p> <ul style="list-style-type: none"> extensive tools library numeric entry of bending parameters usage of the actual database 2D programming of products automatic bending sequence calculation with EC Profiler 2D and 3D graphic display of products programmed offline for Autopol and Radan 	<ul style="list-style-type: none"> SafanDarley EC software Delem Profile on Windows Delem V-Bend Autopol Radan
EC30	<p>As EC20, but with graphical 2D and 3D programming and representation of the bending sequence</p>	<ul style="list-style-type: none"> SafanDarley EC software Delem Profile on Windows Delem V-Bend Autopol Radan
EC40 Smart	<p>In addition to the functionality of the EC20 control, the EC40 Smart offers the option of drawing models on a mobile device (Designer), importing and unfolding 3D drawings, and performing a bending simulation. By "docking" the system with the machine control, data is synchronized, after which the program can be called up in the EC20 and production can start.</p>	<ul style="list-style-type: none"> SafanDarley EC software Delem Profile on Windows Delem V-Bend Autopol Radan

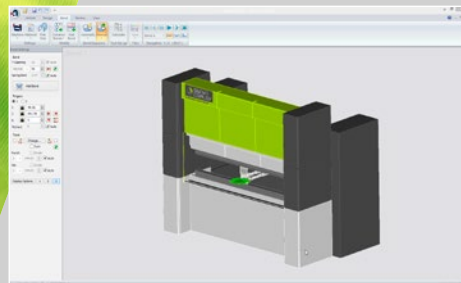

Off-line 3D programming (Autopol)



2D bending instructions (EC20)



2D programming (EC20)



Bending with an E for efficient options

Fast, simple and reliable angle measurement can be essential for your bending process. SafanDarley has made E-evolution advancements in this area too. Two SafanDarley E-Bend systems, electronically linked to the SafanDarley Touch Screen controls, increase your efficiency through exact sheet thickness or angle measurement.

SafanDarley E-Bend S

The SafanDarley E-Bend S sheet thickness measurement system is mounted next to the backgauge finger. The system measures the sheet thickness to an accuracy of ± 0.01 mm. It can be precisely programmed when measurement should take place. Measurement takes just tenths of a second and the data in the control system is immediately adjusted. The control system database maintains all records of measurement and is set out graphically.

SafanDarley E-Bend L Blue

The system consists of two laser sensors, one each side of the table that are CNC controlled through the control system. The system continuously monitors and corrects the

position of the Y axis on the basis of the actual angle of the product, thereby guaranteeing that the end product has the highest degree of angle precision. Where necessary, the system automatically corrects the crowning and takes the spring-back into account.

To that end, the new generation of E-Bend L Blue is equipped with blue laser sensors. This is because the blue light spectrum is much easier to distinguish from "natural" light, so reflections and sunlight can no longer interfere with the measurement. In addition, combined with the new control platform on the E-Control, the new sensor can perform far more measurements per second. This makes the system more accurate, as it is able to respond to measurements sooner.

The E-Bend L Blue (patent pending) can be used in three ways

- Angle measurement with measurement of the spring-back
- Angle measurement with a database
- Angle measurement with learned bending

In the angle measurement with spring-back, the E-Bend L Blue measures at one or three positions during the bending process, corrects the crowning and (Y1 & Y2) positions, and measures the spring-back. These details are then stored in the database. This database is used in angle measurement with a database, making the bending process faster and thus preventing production time from being wasted.



SafanDarley E-Bend S

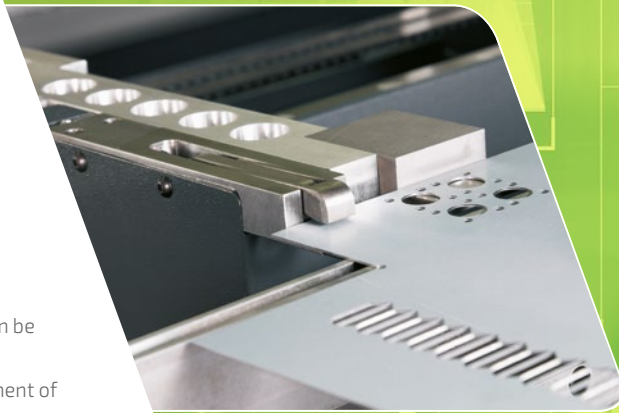

SafanDarley E-Bend L Blue

Increase your efficiency with exact sheet thickness and angle measurements.

SafanDarley E-Mate bending aids

With the electrically-driven E-Mate bending aids from SafanDarley, you prevent angle deviation when bending thin sheets with large dimensions. The bending aid provides the operator with a simple and ergonomic means to remain within set angle tolerances.

It is often not easy for an operator to position large sheets. Certainly during the return movement of the top beam, it is difficult work to keep everything in hand. Instead of having a second operator provide assistance, it is frequently more efficient to install a SafanDarley bending aid. In most cases, it can be used by a single man to position larger products. In brief, along with accuracy, productivity is increased by the SafanDarley E-Mate, the best partner for your operator.

In order to relieve the operator in the case of long,

routine, heavy duty work, SafanDarley has developed an extremely powerful and highly accurate bending aid. The bending aid supports and follows the sheet with great accuracy throughout the entire bending process.

Machine type	Max. sheet weight
• E-Mate	30 kg.
• E-Mate plus	150 kg.



SafanDarley E-Mate Plus bending aids.

More competitive thanks
to no-man production



De E-standard for Ecology



SAFAN
DARLEY

Electronic evolution with an E for ecological and economical

The SafanDarley E-Brake Ultra contributes perfectly to your sustainable business, while at the same time making your business operations much more economic. The absence of hydraulics means that the problems associated with environmentally harmful and risky oil are a thing of the past.

Integrated safety

Work fast without risk: SafanDarley makes that a reality with the safety system integrated within the controls. It works with a safety light screen that is automatically directed from the SafanDarley E-Controls. In addition, the SafanDarley E-Brake Ultra has an additional in-built safety provision. The application of a spring return means that the top beam will always move upwards in the event of a failure.



E-Brake Ultra with an integrated safety system.

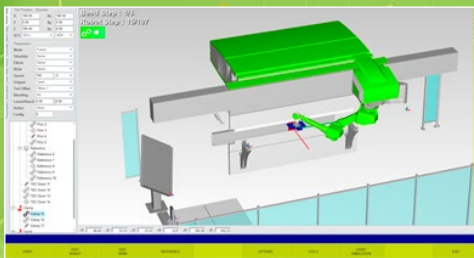

Off-line programming



Turn-key delivery of automated bending solutions

In 1988, SafanDarley had already installed the first robotic press brake in Europe. SafanDarley is now an experienced specialist in the field of automated ending cells including the standard SafanDarley R-Brake. The SafanDarley integral solutions for your production process go much further than stand-alone solutions.

The integral automation is not restricted to the bending cell alone, this also applies to other parts of the process such as punching and spot-welding, and the entire routing of sheet material around the bending cell.

Flexible solutions and off-line software

You retain your flexibility with SafanDarley in terms of new products or changes in your production process. You are also flexible in relation to coupling with external systems and choosing your robot. The SafanDarley

E-Brake is perfectly suited to operate as a mid-point for every automated bending cell. The SafanDarley controls run under the Windows® platform, adding a whole range of options for links, networks, software packages and resolving downtime of the unmanned production process over the Internet. SafanDarley can supply complete, fully tested programs for both new and existing robotic cells. You have a choice between off-line or parametric programming.

Naturally, you can contract out all programming to SafanDarley. The SafanDarley Robowave off-line programming is a guarantee for maximum efficiency of your bending cell. All movements can be programmed and simulated in advance.

From advice & consultancy to manufacturing

SafanDarley makes automation of sheet-metal working easier than you think. This starts with the convenience of a single contact person for the entire project. Our consultants clearly present you with the entire range of options, enabling you to make the best possible choice for your production process. SafanDarley develops and realises turnkey solutions for bending and cutting systems with guaranteed cycle times. This fixes the costs per product. The return time of your investment can be properly determined based on those set costs. With the help of a simulation model, you will get a reliable indication beforehand of your expected Return On Investment.

Energy consumption

On the SafanDarley E-Brake Ultra, the main drive motor is used only when the E-Brake has to actually perform a movement. With a conventional hydraulic press brake, the hydraulic pump motor is running all the time.

Standard features

- SafanDarley EC20 Touch Screen CNC press brake control
- CNC-controlled R- axis
- CNC-controlled Y1-Y2 axis (top beam adjustable inclined +/- 2.5 mm)
- CNC-controlled back gauge (X-axis) with a wide range
- Manual variable adjustment of back gauge fingers width across a linear guide
- NSCL II MC Premium top tool mechanical clamping system and NSCR II MC Premium crowning
- Build in size of 590 mm (Q-dimension)
- 2 support arms (300 mm in length)*
- 1 Hold to Run operating console
- Programmable and integrated safety light guard*
- Safety in conformance with CE*

*Standard only for CE countries

Tool adapters SafanDarley E-Brake

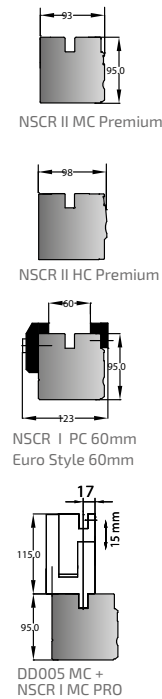
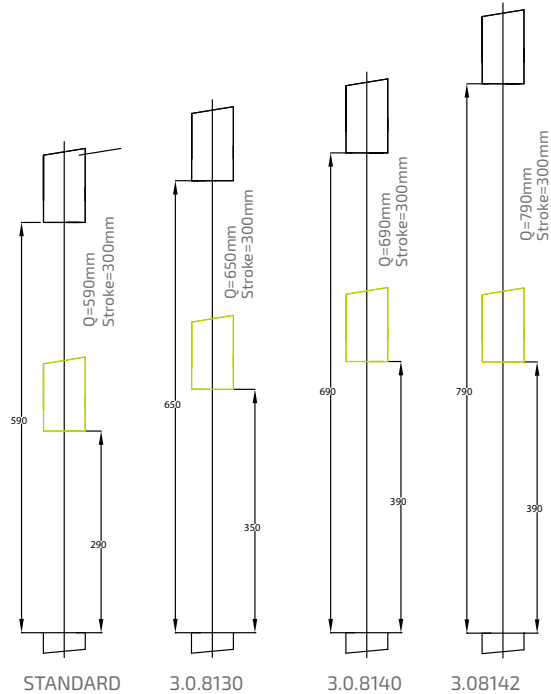
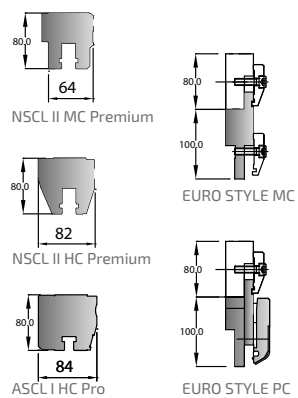

Technical specifications

E-Brake Ultra 50-130T

	Pressure force in kN	Maximum stroke in mm	Q-dimension in mm	Closing speed in mm/sec	Bending speed max.* in mm/sec	Return speed in mm/sec	Motor Power in kW	Weight in kg	A in mm	B in mm	C in mm	D in mm
50-2050	500	300	590	160	20	160	11	5400	2040	3125	2510	2610
80-2550	800	300	590	90	20	90	11	6150	2550	3625	2510	2610
100-3100	1000	300	590	75	20	75	11	6900	3060	4175	2610	2610
130-3100	1300	300	590	130	20	130	15	8950	4080	4175	2710	2810
130-4100	1300	300	590	110	20	110	15	10500	5100	5175	2710	2810

* In CE Version max. bending speed 10 mm/sec

Accessories (optional)

- CNC-controlled Z1-Z2 axis (horizontal repositioning back gauge fingers)
- CNC-controlled Delta X-axis (horizontal repositioning of one back gauge finger)
- Built-in size increase up to 650 mm or 690 mm (Q-dimension)
- Various upper and lower tool adaptors
- Various bending aids
- SafanDarley E-Bend S sheet thickness measurement system
- SafanDarley E-Bend L Blue angle measurement system
- Various support arms, fixed, moveable and adjustable in height where required
- Extra Hold To Run operating console (compulsory with 2 machine operators)
- Integrated tool cabinet
- Machine lighting
- SafanDarley E-Control press brake control:
 - EC30 control, complete 2D and 3D graphic programming
 - EC40 Smart Control

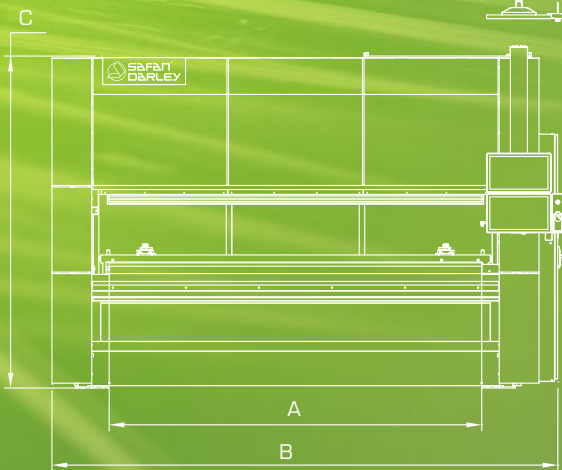
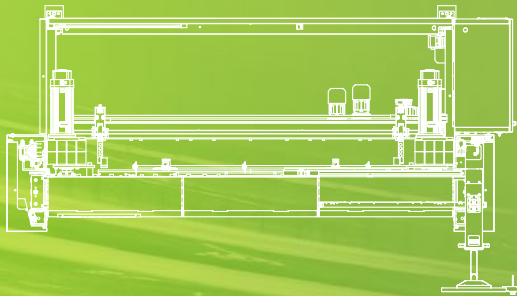
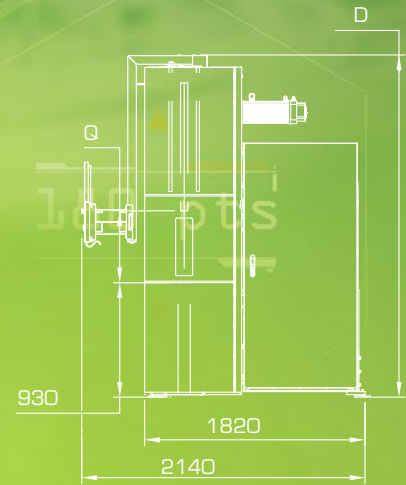



Watch our corporate movie here:



E-Brake Ergonomic



E-Brake 35T-200T
E-Brake B 20T-100T



E-Brake Ultra 50T-130T



E-Brake 300T Dual Drive



E-Brake ATC



H-Brake 175T-400T



H-Brake Hybrid 110T-170T



H-Brake HD 500T-1250T



R-Brake



B-Shear & M-Shear



Special cutting lines

SafanDarley B.V., Kwinkweerd 11, NL-7241 CW Lochem | P.O. Box 96, NL-7240 AB Lochem
Tel.: +31 (0)573 222 222, Fax: +31 (0)573 222 299 | E-mail: info@safandarley.com | Website: www.safandarley.com

