

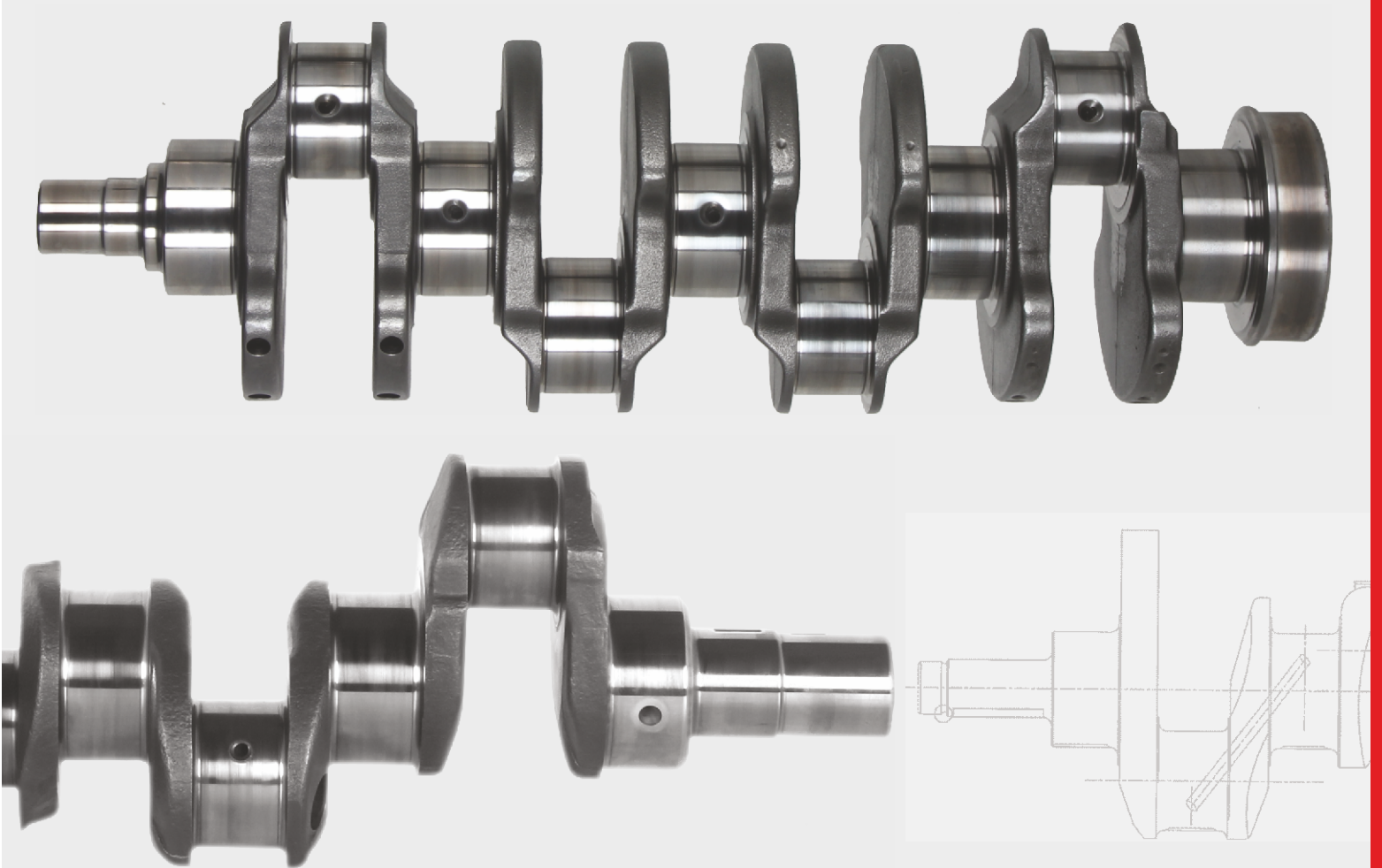

ACTUAL CRANKSHAFT MANUFACTURER



INHOUSE : RAW MATERIAL PRODUCTION + CNC MACHINING

LARGEST CRANKSHAFT RANGE



CRANKSHAFT | CIGÜEÑAL | WAŁ KORBOWY | КОЛЕНЧАТЫЙ ВАЛ | VIRABREQUIN | ARBORE MOTORE | VILEBREQUINS

HEAVY DUTY CRANKSHAFT



SHOT BLASTING



NQT TREATMENT



MASS CENTERING



CNC TURNING CENTER

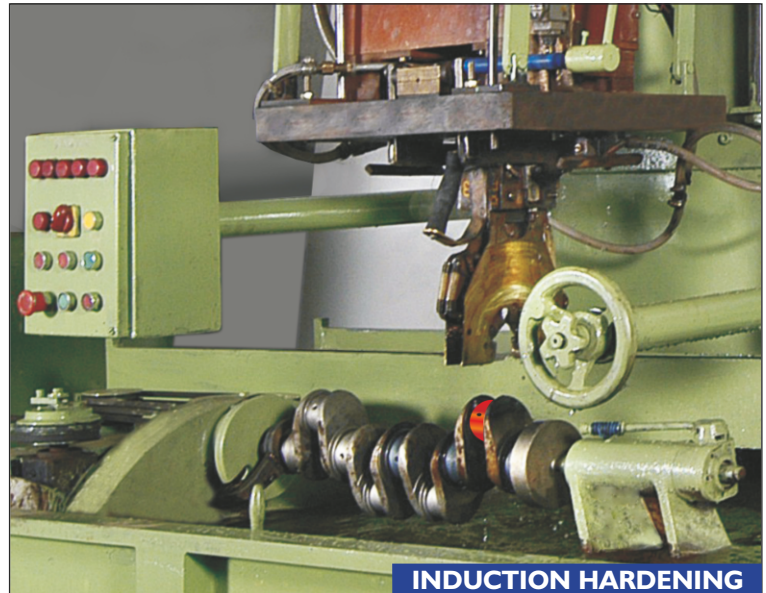

INDUCTION HARDENING



VERTICAL MACHINING CENTER



HORIZONTAL MACHINING CENTER

CRANKSHAFT RANGE

Manufacturer Of All Types Of Heavy Duty Multi-Cylinder Crankshafts

Suitable For:

Tractors, Trucks, Automobiles, Industrial Engines, Compressors, Etc.

INSTALLED CAPACITY

72,000 Units Per Annum

CRANKSHAFT RAW MATERIAL

- Forged Alloy Steel
- Spheroidal Graphite Ductile
- All Crankshaft Raw Material is Normalized, Hardened And Tempered

HI-TECH CRANKSHAFT PRODUCTION LINE

- CNC Mass Centering And Facing Centers
- CNC Machining Centers
- AEG Elotherm Induction Hardening Machines
- CNC Grinders
- HMC Heavy Duty Centers
- VMC Heavy Duty Centers
- Dynamically Balancing Machines
- Special SPM Sand Blasting Unit For Super Crankshaft Finishing

QUALITY CONTROL

- All Crankshafts Manufactured And Inspected Using Hi-Tech Quality Control Systems Strictly In Accordance with ISO 9001:2008 International Standards
- In-House Bruker Germany Spark Spectrometer Unit For Material Analysis
- All Crankshafts Magnafluxed
- STYR Plant :- ISO 9001:2008 Accredited

NEW CRANKSHAFT DEVELOPMENT :

Fully Equipped To Undertake Any New Crankshaft Development.

Inhouse Tool Room and Pattern Shop With CAD/CAM Facility.

Weight Range : 7 kgs. to 110 kgs.

STYR WARRANTY :

We guarantee that all the crankshafts manufactured by us are free from all types of defects both in material and workmanship.

In case of any fitment defect we shall to replace the defective crankshaft free of cost.

Please be advised that 'Styr' liability will be restricted to only the replacement of crankshaft and shall not include payment of any type of compensation towards any consequence arising on account of fitment of any such defective crankshaft.

DISCLAIMER :

All Manufacturer's Symbols, Numbers And Descriptions Are Used In This Catalogue For Reference Purpose Only And Do Not Imply That Any Part Listed Is The Product Of These Manufacturers.

NO. 1 CRANKSHAFT MANUFACTURER

Sr.	Index	Page
1	Allis Chalmers	2
2	Armstrong Siddley	2
3	Bedford	2
4	Belarus – MTZ – JUMZ	2
5	BMC – Morris Oxford	2
6	Case – International Harvester	2-3
7	Caterpillar	3
8	Continental	3
9	Cummins	3
10	Daihatsu	3
11	Deutz	3
12	David Brown	4
13	Fiat	4
14	Fiat - Iveco	4
15	Ford – Ebro – Fordson – New Holland	4-5
16	General Motor	5
17	Hino	5
18	Isuzu	5
19	Jeep Willys	5
20	John Deere	6-7
21	Kubota	7
22	Lada	7
23	Landrover	7
24	Leyland	7
25	Lombardini	7
26	M.A.N.	7
27	Mahindra & Mahindra	12
28	Mazda - Kia	8
29	Mercedes Benz	8
30	Mitsubishi - Hyundai	8
31	MWM Serie	8
32	Navistar	9
33	Nissan	9
34	Perkins MF - Landini	9-11
35	Perkins - IMT – IMR	11
36	Peugeot	11
37	Renault	12
38	Russian "T/D" Series - VTZ	12
39	SMD	12
40	Suzuki	12
41	Tata	12
42	Toyota	12
43	Ursus	12
44	UTB – Romania	12
45	Yanmar Series – Yemen Model	12
46	Zetor	12
47	ZTS	12

SE REF	ENGINE #	PART #	DESCRIPTION
ALLIS CHALMERS			
1654	G 226 226 C.I.D. 70226535	70226535; 70213353; U-3986; 70226526; 70229022; 70241291	SUPER 100, 170 & 175 GAS, W226, 3.7 LITER TRACTORS: WD45 GAS 4 CYLINDER WHEEL LOADERS: TL10 #638-1800; TL11 THRU #73; TL12 THRU #1281
1665	540	172 DIESEL	WITH BALANCER GEAR
1675	160; MF 3 CYL	R 1197987; DIESEL 90814233	MASSEY FERGUSON 35, 50, 150 GAS AND DIESEL
1822	AD3.152. FITS 160	70280077	SPLINED NOSE, ROPE SEAL
ARMSTRONG SIDDLLEY			
1507	2 CYLINDER	20 H.P.	WITHOUT COUNTER WEIGHT
BEDFORD			
1556	J-4 220		4 CYLINDER
1122	J-6 330		6 CYLINDER
BELARUS - MTZ - JUMZ			
1751	MTZ 70 OLD JUMZ D-65	D03-C08-A; 70 HP M-85.17; C-75.17	OIL SEAL : FULL THREADING EGYPT MODEL
1711	MTZ 70 NEW D-65; JUMZ-6KL; JUMZ-6KM	D03-c08-A; 70 HP M-85.17; C-75.17	OIL SEAL : ½ THREADING; ½ KNUURLING
1570	D-240 MTZ-80; MTZ-82	240-1005020-B1; 80 HP	WITH SEPARATE COUNTER WEIGHT 4 CYLINDER
BMC - MORRIS OXFORD			
1114	BMC 1.5 AUSTIN	12H533. 4 CYLINDER	BRITISH LEYLAND U.K.
1113	MORRIS OXFORD	IH 753. 4 CYLINDER	O.H.V. PETROL
1115	BMC 1.5 SAVA	37D212; 80476. 4 CYLINDER	3.013 BMC
1531	BMC 154	37D812. 4 CYLINDER	AUTOLAND 154 TRACTOR
1704	AMBASSADOR	12H165. 4 CYLINDER	SPORTS ENGINE APPLICATION
CASE - INTERNATIONAL HARVESTER			
1141	3110995R91 D154, 154 C.I.D. 2.5 LITER D165, 165 C.I.D. 2.7 LITER D171, 171 C.I.D.	3110995R91; 05700AB; 751303; 751303R2; 751303R3; 751303R5	BD154, 144, 364, 384, 444 TRACTORS 2424, S, SC, SE TRACTORS 780, 880, 885, 4600 TRACTORS 4 CYLINDER
1161	3144626R91 D239 239 C.I.D. 3.9 LITER	3144626R91; 015C1; 3132752R3; 015C1 1089; 3144626; 182752R2; 37CR4; 2744406R1; IH625R2	544, 574, 624, 654, 674, 684 685 BACKHOE 685 TRACTOR, TD7, TD7E, TD8C CRAWLER TRACTORS, TD8 DOZER AVAILABLE WITH : BALANCER GEAR RING; NOSE GEAR 4 CYLINDER
1162	D206 TRACTOR 654 ENGINE 3132968R93 D206, 554, 584	3132968R91; 3132968R93; 1329196CI	AVAILABLE WITH : BALANCER GEAR RING; NOSE GEAR 4 CYLINDER
1823	D206 TRACTOR 624 ENGINE	3055787R92	AVAILABLE WITH : BALANCER GEAR RING; NOSE GEAR 4 CYLINDER
1598	D268 EARLY MODEL 3228376R91 268 C.I.D. 4.4 LTR	3228376R91; 218528R1; 218528R2; 218528R3; 528R2-79; A09-7292; 3.218528R1	510B LOADER NEUSS DIESEL AVAILABLE WITH : BALANCER GEAR RING; NOSE GEAR 4 CYLINDER
1824	D268 NEW MODEL		AVAILABLE WITH : BALANCER GEAR RING; NOSE GEAR 4 CYLINDER
1571	300, 310 GAS	G11700; R1204916	CA 300; 93016233
1655	A39150 188 BUSHING 188 C.I.D. 3.1 LITER 4 CYLINDER	A39150; 976321; A39151; G-11740; G-11741 CASE 188 SMOOTH PILOT CRANK	430, 440, 441, 470, 480, 504, 530, 570, 580, 580B, 630, 640 WHEEL TRACTORS, W3, W5A, 480C, 580C, 1845 WHEEL LOADERS, 2504, 3514, 600, 660, COMBINES, 310E, 310F, 310G, 350, 450 CRAWLER TRACTOR, 1150, 1155, 1255 WINDROWERS, H-25B
1656	A144011 207 NON TURBO 207 C.I.D. 3.4 LITER	A144011; 976321	350, 450, 450B CRAWLERS 580C, 580D WHEEL TRACTOR 4 CYLINDER
1657	CASE 336	251; A267; A2849; 301	NATURAL CRANK. 4 CYLINDER
1658	CASE G148		YEAR 1955 - 1970. 4 CYLINDER
1705	CASE 301		BIG CON. PINS. 4 CYLINDER AVAILABLE WITH BALANCER GEAR RING
1795	IHC GEAR	CRANKSHAFT NOSE GEAR	INTERNATIONAL HARVESTER
1800	A151015 188 SPLINED 188 C.I.D. 3.1 LITER 4 CYLINDER	A151015; 976321; A39151; G-11740; G-11741	430, 440, 441, 470, 480, 504, 530, 570, 580, 580B, 630, 640 WHEEL TRACTORS, W3, W5A, 480C, 580C, 1845 WHEEL LOADERS, 2504, 3514, 600, 660 COMBINES, 310E, 310F, 310G, 350, 450 CRAWLER TRACTOR 1150, 1155, 1255 WINDROWERS, H-25B

SE REF	ENGINE #	PART #	DESCRIPTION
CASE – INTERNATIONAL HARVESTER			
1817	1640; 1644 6 CYLINDER	3907804	2144 COMBINES; CONSOLIDATED DIESEL
1807	D239	IH. 4 CYLINDER	CRANKSHAFT WITH BALANCER GEAR RING & NOSE GEAR
1867	CASE IH 422/M2; 422T/M2; 422T/M3	CASE SKID STEERS 410; 420; 420CT	STROKE : 100 mm. 4 CYL.
1868	CASE IH 422/M2; 422T/M2; 422T/M3	CASE SKID STEERS 410; 420; 420CT	STROKE : 90 mm. 4 CYL.
CATERPILLAR			
1605	1W9771 3204 318 C.I.D. 5.2 LITER	1W9771; 1W0400; OR1206; 4N0111; OR1209; 4N1111; OR5024; 4N111X; OR5164; 4N40012; OR5474; 6N8290; OR5560; 7N5137	D3, 910, 916, 926, 926E, 931 LOADER WHEEL LOADERS : IT12, IT14, IT18, IT28 4 CYLINDER
1651	1397018 3054 244 C.I.D. 4.0 LITER	1397018; 071Z724149; ZZ90082	416, 416C BACKHOE, CAT COMPACTOR : 426B, CB534, CB534B, CB534C, CB545 FORKLIFTS : TH62, TH63, TH82, TH83, TH103, 4.236 PERKINS; 4 CYLINDER
1833	CAT FORKLIFT	PART # 0R4508; ZZ90145	APPLICATION : CAT; HYSTER; YALE & CLARK FORKLIFTS NEW 1004.4T PERKINS; 4 CYLINDER
1855	NEW LATER 3054 MODEL	REPLACES : 7C8214; ZZ90082; 071Z724149; 1397018; ZZ90145	NEW PERKINS 4.236;4.248; 4 CYL.
1857	CAT 3054C; PERKINS 1104	WITH TIMING GEAR RING WEB	SPLINED. LIP SEAL. 3 PULLEY. 10 + 1 FLANGE. 4 CYL.
1869	3024C	CAT SKID STEERS 216; 216B; 226B; 232; 232B; 242B	STROKE : 100 mm. 4 CYL.
1870	3024C	CAT SKID STEERS 216; 216B; 226B; 232; 232B; 242B	STROKE : 90 mm. 4 CYL.
1871	3056	REPLACES OEM # 1930159	WITHOUT MOUNTING FOR RELUCTOR / TIMING GEAR. 6 CYL.
1872	3056E	REPLACES OEM # 1930159	WITH SEPARATE TIMING GEAR MOUNTING PROVISION. 6 CYL.
1873	3056E - GEAR	3116L002/159 - TIMING GEAR	ONLY TIMING GEAR
CONTINENTAL			
1652	830686M91 Z134 - GAS 134 C.I.D. 2.2 LITER	830686M91; Z129C205; Z129C500; Z134C500	GAS Z134, MF35, MF135 4 CYLINDER
1653	Z120; MF T020	MFT020; 47120042; A716357	
CUMMINS			
1816	6BT	3907804	6 CYLINDER
1874	4BT	3907803	4 CYLINDER
DAIHATSU			
1504	DAIHATSU DG	88.0 mm. DIESEL 2530 CC. DELTA	EGYPT MODEL. 4 CYLINDER
DEUTZ			
1603	F1L 511	02233635	1 CYLINDER. WITH SEPARATE COUNTER WEIGHT
1708	F2L 511 D/W	04152745; 20 0505 51102	2 CYLINDER. WITH SEPARATE COUNTER WEIGHT
1826	F2L 511 D/W	04152745; 20 0505 51102	2 CYLINDER. WITH INTEGRATED COUNTER WEIGHT
1689	F2L 912 D/W	02232854; 02929337; 04152591 3371552; 20 0505 91202	WITHOUT COUNTER WEIGHT
1502	F3L 912 172 C.I.D. 2.8 LITER	02929338; 04152646; 210556; 2136928; 20 0505 91203	6240, 6250 3 CYLINDER WITH SEPARATE COUNTER WEIGHT
1194	F4L 912 229 C.I.D. 3.8 LITER	02138819; 02929340; 04152903; 20 0505 91204	6240, 6250 4 CYLINDER WITH SEPARATE COUNTER WEIGHT
1604	F4L 912	02929339; 20 0505 91214	4 CYLINDER. WITH SEPARATE COUNTER WEIGHT AVAILABLE WITH BALANCER GEAR
1195	F6L 912	02929342; 04151011; 2136993; 2136932; 20 0505 91206	6 CYLINDER. WITH SEPARATE COUNTER WEIGHT
1875	F3L 912 172 C.I.D. 2.8 LITER	02929338; 04152646; 210556; 2136928; 20 0505 91203	6240, 6250 3 CYL. WITH INTEGRATED COUNTER WEIGHT
1876	F4L 912 229 C.I.D. 3.8 LITER	02138819; 02929340; 04152903; 20 0505 91204	6240, 6250 4 CYL. WITH INTEGRATED COUNTER WEIGHT
1877	F4L 913	04151013; 02931050; 20 0505 91304	4 CYL. WITH SEPARATE COUNTER WEIGHT
1865	F6L 913	02139148; 02931056; 20 0505 91300	6 CYL. WITH SEPARATE COUNTER WEIGHT
1866	BF6L 913/C/T	02929345; 02139405; 20 0505 91301	6 CYL. WITH SEPARATE COUNTER WEIGHT

SE REF	ENGINE #	PART #	DESCRIPTION
DAVID BROWN			
1558	DB 3/55	K961726; K912017 3 CYLINDER	FITS 780; 785; 880; 885; 1190; 1194; 380CK WITH SEPARATE COUNTER WEIGHT
1174	DB 4/49 AD 4/49	K962224; K917985 4 CYLINDER	FITS 990 LATE S/N
1175	DB 4/55. AD 4/55 DB 219 ENGINE	K962147; K905196; K210100 4 CYLINDER	FITS 990 SELECTOMATIC; 995; 996; 1200; 1210; 1212; 1290; 1294; 1390; 1394; 1400
1825	DB 4/47 AD 4/47	K961007; K908453 4 CYLINDER	FITS 990 IMLEMATIC; 990A; 990B
1650	4/55T DB219T	K963412; K928415 4 CYLINDER	TURBO CHARGED ENGINES FITS 1394; 1410; 1412; 1490; 1494
1804	DB 4/49; AD 4/49	LIBYA MODEL; 4 CYLINDER	SHORT STROKE
FIAT			
1532	FIAT 1100	BA869699	4 CYLINDER
1717	FIAT 1.3 DIESEL		1.3 DIESEL
1663	DAILY ENGINE	8140.61; 8140.21; 8140.67	
1718	DAILY ENGINE		JOURNAL 80 mm. PIN 56 mm. FLANGE 114 mm. 4 CYLINDER
1719	DAILY ENGINE		JOURNAL 76 mm. PIN 56 mm. FLANGE 100 mm. 4 CYLINDER
1715	ALFA ROMEO 1.8		
1716	ALFA ROMEO 2.0		
1799	FIAT 1.3	FIRE ENGINE	GASOLINE
FIAT - IVECO			
1758	480, 474V, 480S, 500S, 540; 3 CYL	4785106	MAIN - 76.2 mm, CON 58.75 mm, STROKE - 110 mm, FLANGE 110 mm, FLANGE HOLE - 07
1173	FIAT 4 CYLINDER	6B 640-640 DT	7 FLANGE HOLES
1759	8040.05.85.12; 35.9 65.9	98451527; 98449226 4 CYLINDER	MAIN 79.8 mm, CON 63.75 mm, STROKE 114 mm, 7 FLANGE HOLE
1760	65.46/70.56/70.66	5088487; 98451529	4 CYLINDER
1786	3 CYLINDER	EGYPT-ALLIS & ROMANIA. 3 CYL	SYRIA-FRSAN. 95 mm
1819	600; 640; 550; 666; 670; 680	4653287	6 FLANGE HOLES
1859	FIAT 750 TRACTOR	OM55 CO3; 4707125; 8818711	4 CYL.
1864	FIAT OM55 CO3	STROKE : 140 MM	4 CYL.
1878	8040.05	98461244	MAIN 76.2 mm, CON 58.75 mm, STROKE 110 mm, FLANGE 95 mm, 6 FLANGE HOLES, SHORT WEB. 3 CYL.
FORD - EBRO - FORDSON - NEW HOLLAND			
1132	EIADDN6303F 220 220 C.I.D. 3.6 LITER	EIADDN6303F; E1ADDNN-6303-D; E1ADDNN-6303-E	FORDSON MAJOR DIESEL & SUPER MAJOR FORDSON POWER MAJOR, FORDSON SERIES D, 4000 SERIES TRACTORS, EARLY MAJOR, FORDSON 5000 SUPER MAJOR. 4 CYLINDER
1133	FORD SERIES D	713F-6303-AAA; 2701E-6303	INDUSTRIAL. 4 CYLINDER
1597	FORDSON		SANZ TYPE. KEYED NOSE. LATE MAJOR. 4 CYLINDER
1137	E0NN6303AA BSD329 4.2 STROKE 175 C.I.D. 2.9 LITER 3 CYLINDER	E0NN6303AA; C5NE6303L; C5NE6303R; C5NE6305; EN438; E5NN-63038-A	2000, 2100, 2110, 2120, 2300, 230A, 2310, 234, 2610,2910, 3000. SUPER DEXTA, 3055, 3100, 3110, 3120, 3150, 3190, 3230, 3300, 3310, 333, 3330, 335, 336, 340, 340A, 3400, 3500, 3550, 3600, 3610, 3900, 3910 GAS 4000 SERIES
1159	F0NN6303MA BSD333 4.4 STROKE 201 C.I.D. 3.3 LITER 3 CYLINDER	F0NN6303MA; C5NE6303N; C5TE6303; E5NN6306N	3930, 3930H, 3930N, 4000, 3930NO, 4000 MAJOR, 4100, 4110, 4130, 4130N, 4130NO, 4140, 4190, 4200, 4330, 4340, 4400, 4410, 4500, 4600, 4600SU, 4610, 4610SU, 4630, 260C, 455, 455C, 455D, 515, 530A, 531, 532, 535, 540, 540A, 540B, 545, 545A, 545C, 550, 555, 555A, 555B SKID LOADERS: L783, L785
1134	C5NE6303K BSD442 4.2 STROKE 256 C.I.D. 4.2 LITER 78 TEETH GEAR	C5NE6303K; 6110A FINIS 81804029	MAJOR 5000, 7000, SUPER MAJOR 5000, 5100, 5190, 5200, 5500, 5550, 5600, 5610, 5700, 6000, 650, 655, 6500, 6600, 6610, 6700, 6710 WHEEL TRACTORS: 7000, 7100, 7200, 7500, 7600, 7610, 7700, 7710 COMBINES: 620, 622 LOADERS: A62, 750, DORSETT 4 CYLINDER
1827	C5NE6303K 4.2 STROKE 78 TEETH GEAR	442 EARLY - PRIOR TO 9/4/1986	WITH REDUCED BALANCER GEAR WIDTH TEETH 4 CYLINDER

SE REF	ENGINE #	PART #	DESCRIPTION
FORD – EBRO – FORDSON – NEW HOLLAND			
1664	C5NE6303K BSD442 4.2 STROKE 256 C.I.D. 4.2 LITER 76 TEETH GEAR	C5NE6303K; 6110A 442 LATE - AFTER 9/4/1986	MAJOR 5000, 7000, SUPER MAJOR 5000, 5100, 5190, 5200, 5500, 5550, 5600, 5610, 5700, 6000, 650, 655, 6500, 6600, 6610, 6700, 6710 WHEEL TRACTORS: 7000, 7100, 7200, 7500, 7600, 7610, 7700, 7710 COMBINES: 620, 622 LOADERS: A62, 750, DORSETT 4 CYLINDER
1160	E5NN6303FA BSD444 4.4 STROKE 268 4.4 LITER 76 TEETH GEAR	E5NN6303FA; D9NN6110AA; D9NN6303A; D9NN6303AA; E5NN6303CA; D5NN6303FA FINIS 83956298; 83918890 444 LATE - AFTER 9/4/1986	655, 6600, 6610, 6700, 7000, 7100, 7200, 7500, 7600, 7610, 7700, 7710 LOADER A62, DORSET DIESEL 4 CYLINDER
1593	E5NN6303DA BSD444 4.4 STROKE 268 4.4 LITER 78 TEETH GEAR	E5NN6303DA; D9NN6110AA; D9NN6303A; D9NN6303AA; E5NN6303CA; D5NN6303FA E5NN6303FA; FINIS 83956298; 83918890	655, 6600, 6610, 6700, 7000, 7100, 7200, 7500, 7600, 7610, 7700, 7710 LOADER A62, DORSET DIESEL 4 CYLINDER
1828	E5NN6303DA 4.4 STROKE 78 TEETH GEAR	444 EARLY - PRIOR TO 9/4/1986	WITH REDUCED BALANCER GEAR WIDTH TEETH 4 CYLINDER
1574	EZJL6300BA 172D 172 C.I.D. 2.8 LITER	E2JL6300BA; B9NN6302B; EZJL6300BAI; UF17095; B9NN6303B	INDUSTRIAL ENGINES: (55-78); TRACTORS: 601, 801, 901, 2000 SERIES, 1801 SERIES, 4000 SERIES, WHEEL LOADERS: 540. ALLIS CHALMERS CS 34. WITH BALANCER GEAR. DIESEL. 4 CYLINDER
1575	FORD 172	UF17090; D4JL6300B; D1NL6300B; D1NL6303D; D1NN6300B; CONN6303J	GAS. 4 CYLINDER. JUBILEE, NAA, 600, 601, 700, 800, 801, 900, 901, 2000, 4000
1197	FORDSON	510 E/R; 5081E63038	6 CYLINDER
1163	TRANSIT	894 F 6303 AB	4 CYLINDER
1779	FORD 4.9		6 CYLINDER
1805	EBRO TRACTOR		LIBYA MODEL. SPLINED. LIP SEAL. 6 CYLINDER
1821	6640	6640. BIG THROW	AVAILABLE WITH SEPARATE BALANCER GEAR. 4 CYLINDER
1858	LEHMAN 2700 SERIES DIESEL ENGINES	CROSS REF VALID CRANKSHAFTS FOR THE 2712E : 713F6303-AAA; 826F6030-DAA; 826F-6030-DBA; 6106523; 6077423; 1606655	FORD SABRE MARINE CONVERSION OF THE LEHMAN DORSET 2712E; DIESEL ENGINE SUITABLE FOR ALL FORD LEHMAN MARINE 4 CYL.
1879	SHIBAURA N844L; N844LT	NEW HOLLAND SKID STEERS C175; L175; L218; L220	STROKE : 100 mm. 4 CYL.
1880	SHIBAURA N844L; N844LT	NEW HOLLAND SKID STEERS C175; L175; L218; L220	STROKE : 90 mm. 4 CYL.
GENERAL MOTOR			
1567	SATURN	U.S. MODEL	4 CYLINDER
1761	CORSA 1.6	90400074	1600 CC. 4 CYLINDER
HINO			
1762	MODEL H07D	HINO CARGO	6 CYLINDER
1829	MODEL 6E	F3349611	6 CYLINDER
1763	HINO 4 CYLINDER 105.50 KGS	GEAR FACE HOLES : 6 + 1 FLANGE HOLES : 8 + 1	MAIN DIA : 99.898 mm, CON DIA : 89.916 mm CON WIDTH : 88.000 mm, THROW : 70.000 mm WITH SEPARATE COUNTER WEIGHT : 6
1764	HINO EF750 4 CYLINDER 103.80 KGS	GEAR FACE HOLES : 4 + 1 FLANGE HOLES : 6 + 1	MAIN DIA : 109.900 mm, CON DIA : 83.900 mm CON WIDTH : 77.000 mm, THROW : 71.000 mm WITH SEPARATE COUNTER WEIGHT : 8
1188	HINO DS 70		HEAVY DUTY. THICK FLANGE. 6 CYLINDER
1881	HINO WO4D	WO4D	4 CYL.
1882	HINO WO6D	WO6D	6 CYL.
ISUZU			
1725	ISUZU 4BC2	5-12310-161-0	EGYPT MODEL. 4 CYLINDER
1777	ISUZU	6VD1	6 CYLINDER
1796	ISUZU	6VE1	6 CYLINDER
JEEP WILLYS			
1139	CJ 3B	647078	WITH SEPARATE COUNTER WEIGHT. 4 CYLINDER
1788	CJ 3B	647078	WITH INTEGRATED COUNTER WEIGHT. 4 CYLINDER

SE REF	ENGINE #	PART #	DESCRIPTION
JOHN DEERE			
3 Cylinder Crankshafts			
1168	AT18031 3-152, 152 C.I.D. 2.5 LITER 3-164, 164 C.I.D. 2.7 LITER 3-179, 179 C.I.D. 2.9 LITER	AT18031; T2351C; T23516 T23516T; T23517T	1020, 1030, 1040, 1120, 1130, 1140, 1520, 1530, 1630, 2020, 2040, 2150, 2155, 2240, 2255, 2355NCS, 2355NTSS, 300, 300A, 300BT, 301, 3018, 302A, 3029, 3029D, 310, 350 3 CYLINDER
1685	RE50979 3-179 3029 POWER TECH 179 C.I.D. 2.9 LITER	RE50979; R101223 2 3/8" FROM END OF SNOOT TO GEAR	2155, 2355N, 2240, 5105, 5205, 5200, 5300, 5400, 5210, 5310, 5310N, 5410, 5510, 5510N, 5220, 5320, 5320N, 5400N, 5500N, 5420, 5420N, 5520, 5520N TRACTORS, 240, 250, 260, 270, 8875 SKID STEER LOADERS, 300 SERIES 3 CYLINDER
4 Cylinder Crankshafts			
1190	AT18030 4-202, 202 C.I.D. 3.3 LITER 4-219, 219 C.I.D. 3.6 LITER 4-239 (EARLY) BELOW SN 769, 619; 239 C.I.D. 3.9 LITER	AT18030; 23909; 97926; 97928; R23517; R81959; R94644; R979266; T23266; T23480T; T23517; T23517T; T28743T SHORT SNOOT NOSE	1640, 1830, 1840, 2020, 2030, 2040, 2100, 2120, 2130, 2250, 2270, 2280, 2320, 2355C2, 2355TSS, 2360, 2420, 2450, 244E, 2510, 2520, 2523, 2555C2, 2650, 2730, 2735, 2750, 2755CS, 2755TSS, 2850, 2855N, 290D, 310, 310B, 310C, 310D, 315C, 3300, 34, 3430, 3830, 401, 401A, 401B, 401C, 401D, 4020, 4030T, 4039D, 4039T, 400, 410, 410B, 515B, 44, 440, 440A, 440B, 450, 450A, 450B, 450C, 450D, 454, 455D, 480, 480A, 480B, 480C, 482C, 490, 499, 515B, 6040, 6200, 6300, 6602, 6620, 6622, 70, 70D 4 CYLINDER
1171	RE20585 4-239 (LATE) ABOVE SN 769, 620 239 C.I.D. 3.9 LITER	RE20585; 23909; 97926; R121018; R81959 LONG SNOOT NOSE	2755, 6040, 4039, 190E EXCAVATOR 300D, 310C, 315C LOADER/BACKHOE 4 CYLINDER
1686	RE56792 4-276D,T 276 C.I.D. 4.5 LITER 4 CYLINDER	RE56792; R108657; R5450; R54501; R54501R	340D, 440C, 448D, 540B, 540D, 548D SKIDDER, 344E, 410C, 444E, 510B, 510C, 610, 610B, 610C, 650G LOADERS 450E, 450G, 455E, 455G, 550, 550A, 550B, 550G, 555, 555A, 555B, 55G CRAWLERS, 490D, 493D, 495D, 590D, 595, 595D EXCAVATOR, 2630, 2640, 6215, 6415
1687	RE54883 4045D, 4045T 276 C.I.D. 4.5 LITER	RE54883; R120009; R90825 LONG SNOOT NOSE	410D, 440G, 510D LOADER; 490E EXCAVATOR 540E SKIDDER, 548E GRAPPLE/SKIDDER 4 CYLINDER
1688	POWER TECH	RE-50618	SNOOT NOSE : 4 HOLES. 4 CYLINDER
1744	4.5 POWER TECH STRAIGHT SNOOT NOSE	RE 504638	TRACTORS: TC444H, 120, 210LE, 310E, 310G, 310SE, 310SG, 315SE, 315SG, 410E, 410G, 444H, 450G, 450H, 455G, 485E, 486E, 488E, 550G, 550H, 555G, 6410, 6410L, 650G, 650H, 5403, 5410, 5415, 5415H, 5420, 5420N, 5425, 5425N, 5510, 5510N, 5520, 5520N, 5525, 5525N, 5605, 5615, 5705, 5715, 5715HC, 6110, 6110L, 6120, 6120L, 6210, 6210L, 6215, 6220, 6220L, 6310, 6310L, 6310S, 6320, 6320L, 6403, 6405, 6410S, 6415, 6420, 6420L, 6510L, 6510S, 6520L SKID STEERS: 260, 270, 280 SPRAYERS: 6700 4 CYLINDER
1745	4.5 POWER TECH TAPER SNOOT NOSE	RE 506195	TRACTORS: 310J, 310SJ, 344H (SN800000>), 3800, 410J, 444J (TIER III SN 611275>), 450J (TIER III SN 159987>), 550J (TIER III SN 159987>), 650J (TIER III SN 159987>), EUROPEAN: SE6010, SE6020, SE6110, SE6120, SE6210, SE6220, SE6310, SE6320, SE6410, SE6420, 5415, 5510, 5510N, 5515, 5605, 5615, 5620, 5705, 5720, 5820, 6010, 6020, 6110, 6110L, 6120, 6120L, 6130, 6205, 6210, 6210L, 6215, 6220, 6220L, 6225, 6230, 6230 PREMIUM, 6310, 6310L, 6310S, 6320, 6320L, 6325, 6330, 6330 PREMIUM, 6405, 6410, 6410L, 6410S, 6415 (ENG SN 196071>), 6420, 6420L, 6420S, 6425, 6430, 6430 PREMIUM, 6510L, 6510S, 6520L BRAZIL: 5403 (ENG. SN 006876>) 4 CYLINDER
6 Cylinder Crankshafts			
1170	AT22562 6-303, 303 C.I.D. 5.0 LITER 6-329, 329 C.I.D. 5.4 LITER 6-359, 359 C.I.D. 5.9 LITER 6059D, T, A 359 C.I.D. 5.9 LITER	AT22562; A102; R108679; A102R; R26550; R26550R; F1910R; R40730; F2729R; RE45541; F2792R; T23264T; F3315R; T-23266; T23266T; F3560R; T23299T; F3561R; T23480T; R108658; T23517T	2840, 2940, 2950, 2955, 3120, 3130, 3140, 3150, 3155TSS, 4030, 4200, 4400, 4420, 4425, 444, 444C, 444CH, 444D, 499, 540, 540A, 540E, 540G, 544, 544A, 544C, 544D, 544E, 544G, 548E, 570, 570A, 570B, 710B, 710C, 710D, 6059D, 5049T, 699, 7484, 9900, 9910, 9920, 9930 6 CYLINDER

SE REF	ENGINE #	PART #	DESCRIPTION
JOHN DEERE			
6 Cylinder Crankshafts			
1742	RE 504639 POWER TECH	RE 515785; RE 52850	STRAIGHT SNOUT NOSE 6 CYLINDER
1743	6.8 POWER TECH 6068HrW60; 6068HRW62 OR 6068HRW71 TIER II ENGINE 414 C.I.D. 6.8 LITER 2 OR 4 VALVE HEAD	RE 505921	544J, 624J, 643J, 644J, 370D, 672D, 7130, 7220, 7320, 7230,7330, 7420, 7520, 7630, 7720, 7730, 7820, 843J, COMBINE: 9550, 9550SH, 9560, 9560SH, 9560STS, 9570STS, COTTON PICKER: 9970, SPRAYER: 4720, 4830 TAPER SNOUT NOSE 6 CYLINDER
1850	6-414, 414 C.I.D. 6.8 LITER 6068D, T, 414 C.I.D. 6.8 LITER	RE 45517	414, 414D, 544B, 544C, 544D, 624E, 624G, 640, 640D, 640E, 643, 643D, 648D, 648E, 648G, 653, 655B, 670, 670A, 670B, 672A, 672B, 690D, 690E, 693D, 750, 750B, 750C, 755, 755A, 755B, 790E. 6 CYL.
1860	6.8 POWER TECH	RE 505124	6 CYL.
KUBOTA			
1559	GA-70, 7.5	TILLER. 1 CYLINDER	SRI LANKA MODEL
1596	RK-80	TILLER. 1 CYLINDER	SRI LANKA MODEL WITH BALANCE PLATE & ALLEN SCREW
1695	L295, 295 DT TRACTOR	1532-23010	EGYPT MODEL. 3 CYLINDER
1818	KND 3200	STATIONARY ENGINE	YEMEN MODEL
LADA			
1533	2103		STROKE 80 mm. 4 CYLINDER
1534	2101 / 2107		STROKE 66 mm. 4 CYLINDER
1720	CTK 70581	52215	STROKE 84 mm. 4 CYLINDER
1721	CTK 70581	52215	STROKE 86 mm. 4 CYLINDER
1722	CTK 70581	52215	STROKE 88 mm. 4 CYLINDER
1883	80 mm STROKE. RUSSIA	WITH POLO HOLE	4 CYL. SUITABLE FOR RUSSIA MARKET
LANDROVER			
1117	MODEL 1948-1954		4 CYLINDER
1176	MODEL 1955-1958	241893	2 LITRE
1177	MODEL 1959-1963	527167	2.25 LITRE
1118	MODEL 1984 ONWARDS	ERC 5014	2.25 LITRE
LEYLAND			
1121	400/401/402/411	F3336611; CJ0004	BRITISH LEYLAND U.K.
1684	154 TRACTOR	4 CYLINDER	BRITISH LEYLAND U.K.
LOMBARDINI			
1506	LDA 450		1 CYLINDER
1766	LDA 450 / 510		1 CYLINDER
1568	1 CYLINDER ITALY	ITALY MODEL	EXTRA LONG KEY / THREADING
1184	LDA 510		SHORT. TAPER DEGREE AFTER GEAR
1679	6LD360		
1696	1 CYLINDER ITALY	ITALY MODEL	FITTED WITH 2 GEARS
1697	LDA 904 L20		2 CYLINDER
1713	LDA 11-D		SERBIA MODEL. 1 CYL.
1714	LDA 12-K		SERBIA MODEL. 1 CYL.
1179	GL 520 API		1 CYLINDER
1180	GL 520 GL 5		6 SPLINES. 1 CYLINDER
1181	GL 520 GL 5		SINGLE KEY FOR PUMP. 1 CYLINDER
1187	MINIDOR		STROKE 44 mm
1884	LDA 510 LONG		STROKE : 45 mm. 1 CYL. SYRIA MODEL
1885	LDA 510 SHORT		STROKE : 45 mm. 1 CYL. SYRIA MODEL
M.A.N.			
1661	D 0846	51.02101.7117	6 CYLINDER. WITH SEPARATE COUNTER WEIGHT
1698	D 2156 / D 2356	51.02101.7123	6 CYLINDER. WITH SEPARATE COUNTER WEIGHT

SE REF	ENGINE #	PART #	DESCRIPTION
MAZDA - KIA			
1523	SL 3500	SL01 11 301 C	4 CYLINDER
1699	SL 3600		4 CYLINDER
MERCEDES BENZ			
1680	OM 352/353 6 CYLINDER	3520303402; 3520306802; 3520307402	WITH SEPARATE COUNTER WEIGHT OIL SEAL : THREADED
1681	OM 352/353 6 CYLINDER	3520300902; 3520303702; 3520305802; 3520307002; 3520307802	WITH SEPARATE COUNTER WEIGHT OIL SEAL : KNURLED
1124	OM 352/A 6 CYLINDER	3520308002	WITH INTEGRATED COUNTER WEIGHT OIL SEAL : KNURLED
1123	OM 352 6 CYLINDER		WITH INTEGRATED COUNTER WEIGHT OIL SEAL : THREADED
1130	OM 314/A 4 CYLINDER	3140302002; 3140303202; 3140305205; 3140305501; 3140306102	WITH INTEGRATED COUNTER WEIGHT OIL SEAL : THREADED
1557	OM 314/A 4 CYLINDER	3140303302; 3140305502; 3140306002	WITH INTEGRATED COUNTER WEIGHT OIL SEAL : KNURLED
1682	OM 314/A 4 CYLINDER	3140303202; 3140305205; 3140306102; 3140302002; 3140305501	WITH SEPARATE COUNTER WEIGHT OIL SEAL : THREADED
1683	OM 314/A 4 CYLINDER	3140303302; 3140305502; 3140306002	WITH SEPARATE COUNTER WEIGHT OIL SEAL : KNURLED
1767	OM 366/A/LA 6 CYLINDER	3660301102; 3660300702	WITH SEPARATE COUNTER WEIGHT OIL SEAL : KNURLED
1158	OM 366/A/LA 6 CYLINDER	3660301602; 3660301502; 3660301402; 3660301102; 3660300702	WITH INTEGRATED COUNTER WEIGHT OIL SEAL : KNURLED
1125	OM 312/321 6 CYLINDER	1210 DI	WITH INTEGRATED COUNTER WEIGHT OIL SEAL : THREADED
1126	OM 312/321 6 CYLINDER	1210 SE	WITH INTEGRATED COUNTER WEIGHT OIL SEAL : KNURLED
1768	OM 355/OM 355A	3550306701; 3550306801	WITH SEPARATE COUNTER WEIGHT
1787	OM 366/A/LA 6 CYLINDER		WITH INTEGRATED COUNTER WEIGHT OIL SEAL : THREADED
MITSUBISHI - HYUNDAI			
1146	T-120 COLT	M - 111 JAPAN	4 CYLINDER
1145	ME013668; 4D31; 201 C.I.D.	ME013668; 11-220	FE TURBO DIESEL TRUCK. M111. 4 CYLINDER
1606	4D34		4 CYLINDER
1572	T-120 SS		4 CYLINDER
1595	4D55		4 CYLINDER
1746	MITSUBISHI 6D 22 6 CYLINDER	GEAR FACE HOLES : 6 + 1 FLANGE HOLES : 8 + 1	MAIN DIA : 100.000 mm, CON DIA : 84.000 mm, THROW : 70.000 mm. 111.60 KGS.
1765	MITSUBISHI 6D 16 6 CYLINDER	GEAR FACE HOLES : 6 + 1 FLANGE HOLES : 6 + 1	MAIN DIA : 79.950 CON DIA : 64.940 mm, THROW : 57.500 mm. 58.00 KGS.
1792	HYUNDAI	23100-41001	IRAN MODEL. 4 CYLINDER
1801	4D32		4 CYLINDER
1802	4D33		4 CYLINDER
1803	4D35		4 CYLINDER
1594	MITSUBISHI M25	HD 330. HP 25	YEMEN MODEL. WITHOUT BALANCE WEIGHT & GEAR
1861	HYUNDAI H 100	10231694	4 CYL.
1863	MITSUBISHI 4D56	4D56	4 CYL.
MWM SERIE			
1700	D 229 4 CYLINDER	118670; 118690	WITH SEPARATE COUNTER WEIGHT AVAILABLE WITH BALANCER GEAR RING
1811	SERIE 10. 4 CYL	IVW-X104	AVAILABLE WITH BALANCER GEAR RING
1812	SERIE 10	IVW-X106	6 CYLINDER

SE REF	ENGINE #	PART #	DESCRIPTION
NAVISTAR			
1676	3110995R91 D154, 154 C.I.D. 2.5 LITER G164, 164 C.I.D. 2.7 LITER D165, 165 C.I.D. 2.7 LITER D171, 171 C.I.D. 2.8 LITER	3110995R91; 05700AB; 751303; 751303R2; 751303R3; 751303R5; 8629 (DB TRACTOR)	144, 364, 384, 444 TRACTORS S, SC, SE TRACTORS GAS, 350, 500B, 600B, 780, 880, 885, 4600 TRACTORS 4 CYLINDER
1677	3144626R91 D239 239 C.I.D. 3.9 LITER	3144626R91; 015C1; 3132752R3; 015C1 1089; 3144626; 182752R2; 37CR4; 2744406R1; IH625R2	544, 574, 674, 684, 685 BACKHOE 685 TRACTOR, TD7, TD7E, TD8C CRAWLER TRACTORS, TD8 DOZER. AVAILABLE WITH BALANCER GEAR RING 4 CYLINDER
1678	3228376R91 D268 268 C.I.D. 4.4 LITER	3228376R91; 218528R1; 528R2-79; 218528R2; A09-7292; 218528R3; 3.218528R1	510B LOADER NEUSS DIESEL (GERMAN BUILT) AVAILABLE WITH BALANCER GEAR RING 4 CYLINDER
NISSAN			
1797	NISSAN MODEL NE6	CPB12	6 CYLINDER
PERKINS MF - LANDINI			
3 Cylinder Crankshafts			
1101	31312436 3.152 ROPE 152 C.I.D. 2.5 LITER 3 CYLINDER	31312436; 026005M1; 736532M91; 31312419; 84402; 31312436; SD260034; 31312441; U5BG0031; 31312700; ZZ90084; 3637454M91; ZZ90116; 467; ZZ90148	KEYED NOSE. ROPE SEAL AGRICULTURAL: MF-35, 135, 148, 230, 240, 250, 254, 254S, 255, 350, 353, 355, 360, 363, 550 INDUSTRIAL: MF-20B, 20D, 20E, 20F, 30E, EPH, 40, 40E MF-LANDINI C4500, R-DT5500
1666	3.152. 3 CYLINDER	84399; 31312437	SPLINED NOSE. ROPE SEAL
1729	3.152; D3.152 3 CYLINDER	ZZ90148; ZZ90116; 3638309M91; 84402	KEYED NOSE. ROPE SEAL FITTED WITH COUNTER WEIGHT, WASHER & SCREW ALSO AVAILABLE WITH NOSE GEAR
1102	31312701 3.152 LIP 152 C.I.D. 2.5 LITER 3 CYLINDER	026053M; 94458; 31312701; 94464; 31312707; U5BG0027; 31315135; ZZ90078; 3637410M91; ZZ90150; ZZ90122; 637399M91	KEYED NOSE. LIP SEAL AGRICULTURAL: MF-135, 148, 230, 240, 250, 254, 254S, 255, 350, 353, 355, 360, 363, 550 INDUSTRIAL: MF-20B, 20D, 20E, 20F, 30E, 30H, 40, 40E MF LANDINI C4500, R-DT5500
1667	3.152 3 CYLINDER	31312702; 31312704; 94463; 94459; ZZ90117	SPLINED NOSE. LIP SEAL
1730	3.152 3 CYLINDER	3132.0002K96/3	KEYED NOSE. LIP SEAL FITTED WITH COUNTER WEIGHT, WASHER & SCREW ALSO AVAILABLE WITH NOSE GEAR
1888	PERKINS 1103 CRANKSHAFT	1103 / 1103B-33 / 1103C-33 / 1103C-33T	LIP SEAL. 3 PULLEY. 6 + 1 FLANGE. 3 CYL. 72300101- LOVOL DIESEL; 4181V017 - PERKINS DIESEL
1889	3.152 3 CYL.	84399; 31312437	SPLINED. ROPE. WITH COUNTER WEIGHT ALSO AVAILABLE WITH NOSE GEAR
1890	3.152 3 CYL.	31312702; 31312704; 94463; 94459; ZZ90117	SPLINED. LIP. WITH COUNTER WEIGHT ALSO AVAILABLE WITH NOSE GEAR
4 Cylinder Crankshafts			
1834	31315824 4.108 ROPE 107 C.I.D. 1.8 LITER 4 CYLINDER	31315824; ZZ90124; 84417; U5BG0056	ROPE SEAL 445, 4600M, L555 SKID LOADER E146 LOADER, M434-4 TRENCHER INDUSTRIAL, MARINE
1103	31315145 4.203 ROPE 203 C.I.D. 3.3 LITER 4 CYLINDER	026008MI; 3638473M91; 31315135; 742742M91; 31315138; 84407; 31315145; 85811; 31315148; 92484; 31315167; 92485; 31315184; U5BG0017; ZZ90121; U5BG0028; 3637399M91	KEYED NOSE. ROPE SEAL A4.203, AD4.203, AG3.152 GAS MF-65, 150, 155, 158, 165, 650, 765, MF-INDUSTRIAL 50, LANDINI PERKINS, 192, A4, R-DT6000
1668	4.203; D4.203 4 CYLINDER		SPLINED NOSE. ROPE SEAL
1104	31315184 4.203 LIP KEYED NOSE 203 C.I.D. 3.3 LITER	026032M1; 94441; 31315182; 94454; 31315184; 94455; 742344M91; ZZ90111; 026033; 3637458M91	KEYED NOSE. LIP SEAL. 4 CYLINDER A4.203, AD4.203 MF-65, 155, 158, 165, 650, 765 MF-INDUSTRIAL 50, LANDINI PERKINS A4.203, R-DT6000

SE REF	ENGINE #	PART #	DESCRIPTION
PERKINS MF - LANDINI			
4 Cylinder Crankshafts			
1669	31315181 4.203 LIP SPLINED NOSE 203 C.I.D. 3.3 LITER	026032M1; 94441; 31315181; 94454; 31315182; 94455; 31315184; ZZ90111; 742344M91	SPLINED NOSE. LIP SEAL. 4 CYLINDER HYSTER CHALLENGER 860C FORKLIFT
1105	4.236 / 4.248 4 CYLINDER HEAVY WEIGHT	3637789M91; U5BG0054; 31315911; 31315912; 84422; 85721; ZZ90093; 84421; 94434; 7340893M1; 31315851; 68050; 31315884	SPLINED NOSE. ROPE SEAL. EW MF 178, 185, 188, 194-F, 285, 294S-4S, 393, 397 MF INDUSTRIAL 50E/EX, 60H, 60H "S" SERIES MF LANDINI R-DT8500, C7800, C7830 PERKINS A4.248, 4.248
1106	4.236 / 4.248 4 CYLINDER HEAVY WEIGHT	3637401M91; U5BG0024; 31315981; 31315982; 31315991; 94435; 94436; ZZ90082; ZZ90081; ZZ90143; 741747M1	SPLINED NOSE. LIP SEAL. EW MF 265, 274, 274S, 274SK, 275, 285, 284S-4S, 365, 373, 375, 377, 383, 387, 565, 575, 675, 3050, 194-F, 285, 294-S-4S, 393, 397, 178, 185, 188 MF LANDINI R-DT6550, MF LANDINI R-DT8500, PERKINS A4.236, PERKINS A4.248, C6830, R-DT7550, R-DT7530F, 4.248 MF COMBINES 440, MF INDUSTRIAL 50, 50B, 50E/EX, 50H/HX, 50H/HX 'S' SERIES, 60H, 60H 'S' SERIES
1769	4.236 / 4.248 4 CYLINDER HEAVY WEIGHT	ZZ90202; ZZ90081; 364040M91; 3665768M2	SPLINED NOSE. LIP SEAL. EW 12 FLANGE HOLES
1770	4.236 / 4.248 4 CYLINDER HEAVY WEIGHT	364040M91; 3665768M2	SPLINED NOSE. LIP SEAL. EW 12 FLANGE HOLES. 3 PULLEY HOLES
1107	4.236 / 4.248 4 CYLINDER LIGHT WEIGHT	31315911; 31315912; 84422; 85721; ZZ90093; 736829M91; ZZ90108; 3637789M91; 3639541M1	SPLINED NOSE. ROPE SEAL MF 168, 175, 178, 185, 188, 265, 274, 274S, 274SK, 275, 285, 284-4S, 365, 373, 375, 377, 383, 387, 565, 575, 675, 3050. MF LANDINI R-DT7500, R-DT6550, C6830, R-DT7550, R-DT7530F, PERKINS 4.236; A4.236 MF COMBINES 440, MF INDUSTRIAL 50, 50B, 50E/EX, 50H/HX 'S' SERIES
1670	4.236 / 4.248 4 CYLINDER LIGHT WEIGHT	U5BG0026; 31315664	SPLINED NOSE. ROPE SEAL 3 PULLEY HOLES
1108	4.236 / 4.248 4 CYLINDER LIGHT WEIGHT	31315871; 31315631; 31315641; 31315664; 85821; 94433; 94434; 26042; 26046; U5BG0052; ZZ90122; ZZ90082; 736829M91; 741750M1; UR040591/3	SPLINED NOSE. LIP SEAL MF 158, 175, MF LANDINI R-DT7500
1736	4.236 / 4.248 4 CYLINDER LIGHT WEIGHT	ZZ90143; 3641031M91	SPLINED NOSE. LIP SEAL 3 PULLEY HOLES
1737	4.236 / 4.248 1004 SERIES 4 CYLINDER LIGHT WEIGHT	ZZ90119; ZZ90202; PHASER 90 ENG.	LONG NOSE. SPLINED. LIP SEAL 3 PULLEY HOLES
1551	4.212; D4.212	85719; ZZ90100; ZZ90076; 3637457M91; 737189M91	KEYED / SPLINED NOSE. ROPE SEAL MF 165 WITH A4.212. 4 CYLINDER
1552	4.212; D4.212	94430; ZZ90077; 3637453M91; 742873M91	KEYED / SPLINED NOSE. LIP SEAL MF 165 WITH A4.212. 4 CYLINDER
1662	Te20, MF35, 135	825216M1	PETROL MODEL
1709	TEF20 DIESEL MF35; 23C DIESEL	302205; 1884134M91	4 CYLINDER
1790	NEW 1004.4T	PHASER 135 TI; 110 TI; ZZ90145	LIP SEAL. 3 PULLEY HOLES. 4 CYLINDER
1791	4.236 / 4.248 4 CYLINDER	31315661 HEAVY WEIGHT	SPLINED NOSE. LIP SEAL. EW 6 + 1 FLANGE HOLES. 3 PULLEY HOLES
1798	Y.236 4 CYLINDER	ZZ90082 HEAVY WEIGHT	SPLINED NOSE. ROPE SEAL. EW 6 + 1 FLANGE HOLES. 3 PULLEY HOLES
1820	PERKINS 1004G; SERIES 1004-4	ZZ90238 4.236; 4.248	NEW 1000 SERIE; 1004-40; 1004-42; 100 SERIE EW 4 CYLINDER
1835	4.236 / 4.248 SUPERCEDE VERSION	31315993	SPLINED NOSE. ROPE SEAL. HEAVY CRANKSHAFT 4 CYLINDER
1836	4.236 / 4.248 1004 / 1004.42 SERIES	NEW PHASER VERSION	SPLINED NOSE. LIP SEAL 3 PULLEY HOLES. 4 CYLINDER ALSO AVAILABLE IN HEAVY CRANKSHAFT VERSION
1837	4.236 / 4.248 1104 SERIES	NEW VERSION ELECTRONIC ENGINE	LONG NOSE. SPLINED. LIP SEAL 3 PULLEY HOLES. 4 CYLINDER ALSO AVAILABLE IN HEAVY CRANKSHAFT VERSION
1838	4.236 / 4.248 TURBO ENGINE	ZZ90212	SPLINED NOSE. LIP SEAL. 10 FLANGE HOLES 3 PULLEY HOLES. TUFFTRIDED. 4 CYLINDER

SE REF	ENGINE #	PART #	DESCRIPTION
PERKINS MF - LANDINI			
4 Cylinder Crankshafts			
1839	1004 / 1104 SERIES	ZZ90222	SPLINED NOSE. LIP SEAL. 10 + 1 FLANGE HOLES 3 PULLEY HOLES. HEAVY CRANKSHAFT. 4 CYLINDER TIMING RING FITMENT PROVISION
1710	1 THRUST PLATE 3 BOLTS		SUITABLE FOR 4.248/4.236/6.354 CRANKSHAFT
1851	400 SERIES	PERKINS; 404C-2.2 / 115256990	STROKE : 100 mm. 4 CYL.
1852	PERKINS 1004 TURBO ENGINE	PHASER SERIES. ZZ90212	SPLINED NOSE. LIP SEAL. 3 PULLEY HOLES. 10 + 1 FLANGE. NITRIDING. 4 CYL.
1853	1004/1104 SERIES	PERKINS; WITH TIMING RING FITMENT PROVISION.	SPLINED. LIP. 3 PULLEY HOLES. 10 + 1 FLANGE. 4 CYL.
1854	400 SERIES	PERKINS; 404C-2.2 / 115256750	STROKE : 90 mm. 4 CYL.
1862	PERKINS ZZ90093	MF : 3639541M1; JCB : 02101158	SPLINED. LIP. 3 PULLEY. 10 + 1 FLANGE. 4 CYL.
6 Cylinder Crankshafts			
1109	6.305	31323146; 84433; 026020N	KEYED NOSE. ROPE SEAL. 6 CYLINDER
1690	6.305		KEYED NOSE. LIP SEAL. 6 CYLINDER
1553	6.354.4 6 CYLINDER	U5BG0037; ZZ90113; 3637408M91	KEYED NOSE. ROPE SEAL. MF 399, 699, 1014, 1114, 1134, 1250, 2620, 2640, 2645, 2680, 2685, 2720, 2725, 3080, 3090, 3650 MF COMBINES 24, 27, 29, 29XP, 31, 530, 535, 560, 565, 620, 625, 660, 665, 750, 800, 805, 825 MF LANDINI R-DT1000, R-DT100005, R-DT12500, R-DT1300 MKII, R-DT14500 MKII, PERKINS A6.354.4, A6.372.4
1775	6.354.4	ZZ90196	KEYED NOSE. ROPE SEAL. 3 PULLEY HOLES. 6 CYLINDER
1741	6.354.4 6 CYLINDER	31314021; 313111021; 68076; ZZ90086; 3637404M91; ZZ90113; 748751M1	KEYED NOSE. LIP SEAL. MF 2705, 3525, 3545, 3630, 3650 MF COMBINES 550, 750, 760, 850, 860 MF LANDINI R-DT14500, PERKINS A6.354.4, T6.354.4
1554	6.354.4; 6 CYL.	U5BG0035; 313H021	KEYED NOSE. LIP SEAL; 3 PULLEY HOLES
1560	6.354.4	ZZ90105; 3131H022	KEYED NOSE. LIP SEAL. TUFFTRIDED. 6 CYLINDER
1776	6.354.4 6 CYLINDER	U5BG0038; 3637406M91; 4224054M91	KEYED NOSE. LIP SEAL. 3 PULLEY HOLES TUFFTRIDED
1671	1006 PHASER SERIES	3637019M91; ZZ90218	KEYED NOSE. LIP SEAL. 3 PULLEY HOLES WITHOUT GEAR COLLAR STEP. 6 CYL.
1110	6.354.2 6 CYLINDER	31322361; 31322316; 31322317; 31322363; 31322364; 68063; 85727; 68063; ZZ90089; U5BG0045; 742150M1; 736902M1	SPLINED NOSE. ROPE SEAL. MF 1100, 1014, 1200 MF COMBINES 500, 510, 515, 520, 525, 620, 625 MF LANDINI R-DT9500, R-DT10000, R-DT10005 PERKINS A6.354, PERKINS A6.354.1, A6.354.2, A6.372.1
1555	6.354.2 6 CYLINDER	31323261; 31323262; 94468; 94460; 94443; ZZ90090; U5BG0048; 742160M1; 742161M1	SPLINED NOSE. LIP SEAL. MF 1100, 1014, 1200 MF COMBINES 500, 510, 515, 520, 525, 620, 625 MF LANDINI R-DT9500, R-DT10000, R-DT100005, PERKINS A6.354, A6.354.1 A6.354.2, A6.372, A6.372.1
1701	PERKINS 6.358 6 CYLINDER	635855	SPLINED NOSE. LIP SEAL HEAVY DUTY CRANKSHAFT
1789	PERKINS 1106	PHASER 180TI; 6.354 PHASER 3638402M91; ZZ90085; ZZ90087	KEYED NOSE. LIP SEAL. 3 PULLEY HOLES. 6 CYL.
1806	6.305	EBRO TRACTOR	LIBYA MODEL. SPLINED. LIP SEAL. 6 CYLINDER
1840	PERKINS 4225497M1	PERKINS : ZZ90213 MF : 3637019M91	KEYED NOSE. LIP SEAL. 3 PULLEY HOLES. 6 CYL. WITH SEPARATE TIMING RING
1887	1106 SERIES TIMING RING	PERKINS. 3116L002/159	LOOSE TIMING RING
PERKINS - IMT - IMR			
1780	3.152 3 CYLINDER	IMT 539. M33. 813674	KEYED NOSE. ROPE SEAL. mm THREADING FITTED WITH COUNTER WEIGHT, WASHER & SCREW
1781	3.152 3 CYLINDER	IMT 549. DM33	KEYED NOSE. LIP SEAL. mm THREADING FITTED WITH COUNTER WEIGHT, WASHER & SCREW
1793	4.203; R-65. A4203	IMR 60. M34. IMT 560. MF-65. 65	KEYED NOSE. ROPE SEAL. mm THREADING. 4 CYL.
1794	4.203 LIP	IMR 65. 700147; DM34	KEYED NOSE. LIP SEAL. mm THREADING. 4 CYLINDER
1813	IMR S44/V	4.236. LIGHT WEIGHT; 4 CYL.	AVAILABLE WITH ROPE SEAL / LIP SEAL. mm THREADING
1778	IMR S44/T	4.248. HEAVY WEIGHT; 4 CYL.	AVAILABLE WITH ROPE SEAL / LIP SEAL. mm THREADING
1814	IMR S46	6.354. 6 CYL.; SPLINED NOSE	AVAILABLE WITH ROPE SEAL / LIP SEAL. mm THREADING
1815	IMR TS46	T6.354. 6 CYL.; KEYED NOSE	AVAILABLE WITH ROPE SEAL / LIP SEAL. mm THREADING
PEUGEOT			
1539	504		WITH SEPARATE COUNTER WEIGHT. 4 CYLINDER
1706	XDP40		4 CYLINDER

SE REF	ENGINE #	PART #	DESCRIPTION
RENAULT			
1562	12.1400 MOTOR	7700564485	4 CYLINDER
1723	1.6 GASOLINE		4 CYLINDER
1724	2.2 DIESEL		4 CYLINDER
RUSSIAN "T/D" SERIES - VTZ			
1503	T-25. VTZ T-25 A	D21-10005007-A2; D21-1005011-A3	DIA Ø 12. DIA Ø 14 WITH SEPARATE COUNTER WEIGHT. 2 CYLINDER
1702	T-25; T-16 D-120	Z1-100501143; D21-10050115	DIA Ø 12. DIA Ø 14 WITH INTEGRATED COUNTER WEIGHT. 2 CYLINDER
1703	T-40; LTZ T-40M	D 144-1000 120-10	WITH SEPARATE COUNTER WEIGHT. 4 CYLINDER
1752	D144. T-40	D -371005011B; D37M-1005011-B	WITH INTEGRATED COUNTER WEIGHT. 4 CYLINDER
SMD			
1753	SMD 18/22 SMD-20	20-04c9 206167	JUMZ 6M; DT-75; NIVA; JENISEJ RUSSIA & UKRAINE. 4 CYLINDER
1754	SMD-60 / T-150	60-04001-00; Z0-0401 102227	JUMZ. WITH SEPARATE COUNTER WEIGHT RUSSIA & UKRAINE
1755	T-150		WITH INTEGRATED COUNTER WEIGHT. RUSSIA & UKRAINE
SUZUKI			
1142	SUZUKI 800		3 CYLINDER
1143	SUZUKI SJ 410	1222175101	1000 cc. 4 CYLINDER
1522	SUZUKI SJ 413		4 CYLINDER
1771	SUZUKI V6		6 CYLINDER
TOYOTA			
1573	TOYOTA 1Y	22re 4 Cil 2.4L	4 CYLINDER
URSUS			
1147	URSUS C-330	42.03105.0/3	2 CYLINDER
1830	URSUS	C-330	2 CYLINDER
1659	URSUS C-360	46.40399.0/3	HEAVY DUTY (URSUS II). 4 CYL.
1193	URSUS	S-4003	ZETOR TYPE. 4 CYL.
1886	URSUS C-385	83.003.501	HEAVY DUTY (URSUS II). 4 CYL.
1887	URSUS C-385	89.003.503	HEAVY DUTY (URSUS II). 6 CYL.
UTB - ROMANIA			
1153	UTB 650	10303010	SMALL FLANGE. ROPE SEAL. 4 CYLINDER
1154	UTB 660	2402.03.0301; 10303020	BIG FLANGE. LIP SEAL. 4 CYLINDER
YANMAR - HYUNDAI - KUBOTA - ANDORIA - STATIONARY ENGINE			
1566	YANMAR TS 160		
1672	YANMAR N22Y	SHORT TYPE MAIN BEARING	YEMEN MODEL. WITHOUT BALANCE WEIGHT & GEAR
1569	YANMAR N22Y - N28Y	LONG TYPE MAIN BEARING	YEMEN MODEL. WITHOUT BALANCE WEIGHT & GEAR
1673	YANMAR NP	N15Y - NP16 - NP17	YEMEN MODEL. WITHOUT BALANCE WEIGHT & GEAR
1831	YANMAR NP	NP30	YEMEN MODEL. WITHOUT BALANCE WEIGHT & GEAR
1594	MITSUBISHI M25	HD 330. HP 25	YEMEN MODEL. WITHOUT BALANCE WEIGHT & GEAR
1674	ANDORIA S 320	18 HP	YEMEN MODEL. WITHOUT BALANCE WEIGHT & GEAR
1818	KUBOTA KND 3200	KND 3200	YEMEN MODEL. WITHOUT BALANCE WEIGHT & GEAR
ZETOR			
1151	2011	20010301	CZECHOSLOVAKIA. 2 CYL.
1152	3011	30010301	CZECHOSLOVAKIA. 3 CYL.
1785	3001.0399	3001.0399/3	3 CYLINDER
1660	7711	7101.0399/3	HEAVY DUTY. 4 CYL.
1832	4001.0399	4001.0399/3	HEAVY DUTY. 4 CYL.
1707	4911/5911/5945/ 6911/6945		4 CYLINDER
1508	CZECHOSLOVAKIA S-50	17.0204	4 CYLINDER
1773	78.003.001/3	78.003.001/3	HEAVY DUTY. 4 CYL.
ZTS			
1772	83.003.501	83.003.501/3	HEAVY DUTY. 4 CYL.
1774	89.003.503	89.003.503/3	HEAVY DUTY. 6 CYL.
TATA		MAHINDRA & MAHINDRA	
Crankshaft Range Available On Request		Crankshaft Range Available On Request	



CNC GRINDERS



DYNAMIC BALANCING



HORIZONTAL MACHINING CENTER



QUALITY CONTROL



EXPORT PACKING

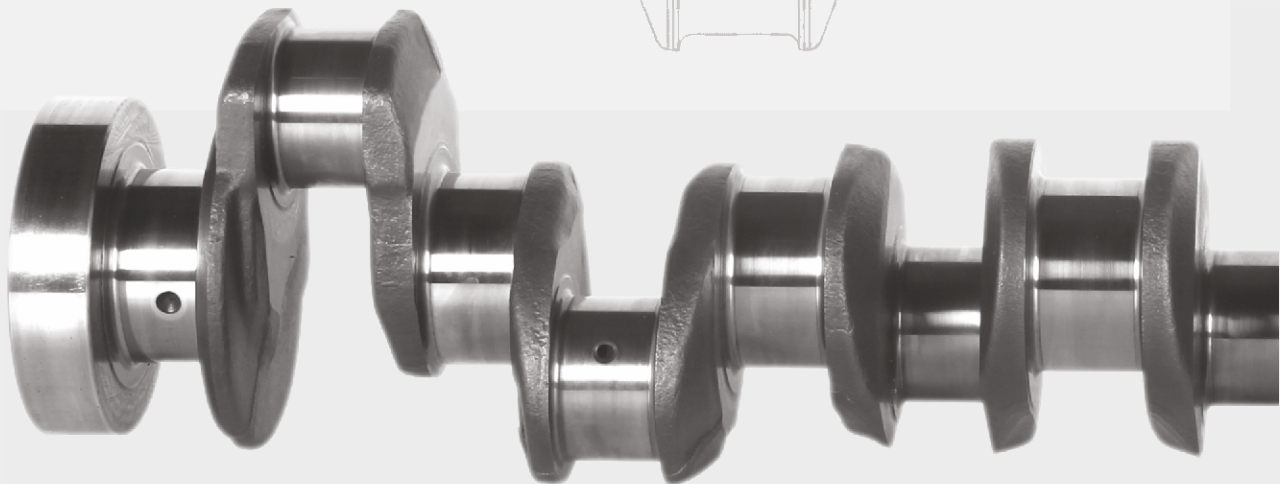
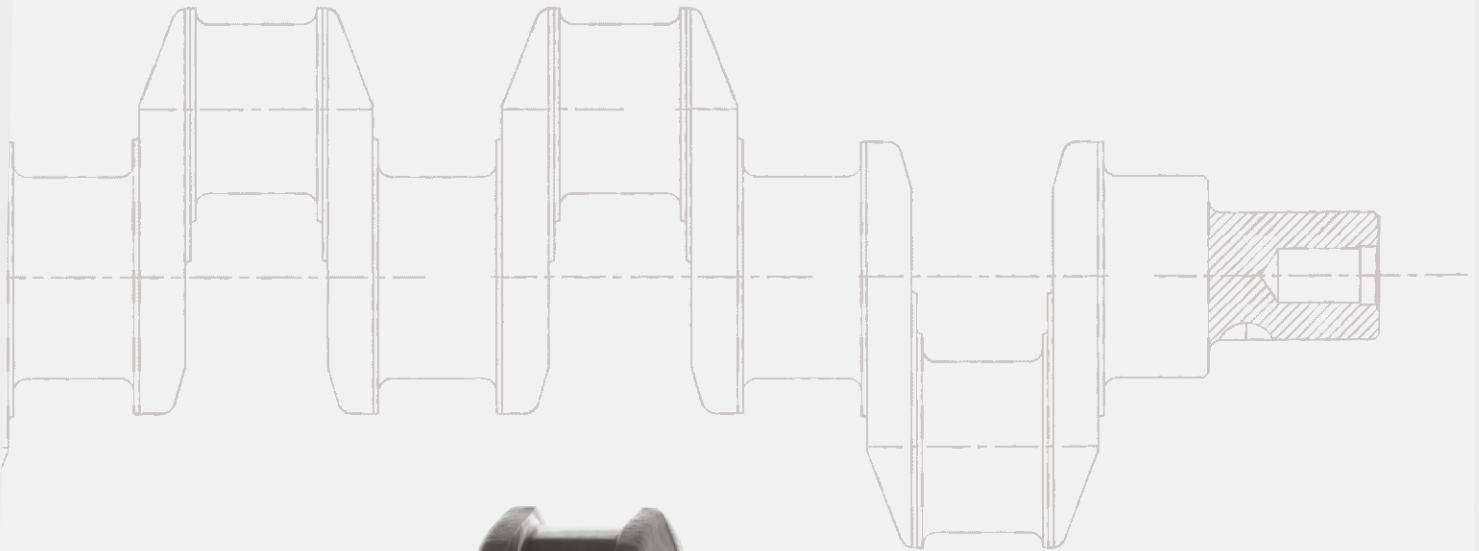

STYR EXPORTS

STYR - CORPORATE OFFICE :

103, Imperial Palace, 45, Telly Park Road,
 Andheri (East), Mumbai - 400 069, India
 Tel : +91-22-26822482, 26833162, 26833163
 Fax : +91-22-26841710, 23826668
 E-Mail : styr@vsnl.com / styrexports@gmail.com

STYR - CRANKSHAFT PLANT :

43, Kakti Industrial Area, Kakti,
 Belgaum - 591 113, India
 Tel : +91-831-2470681 / 2473237
 Fax : +91-831-2473736

URL : www.styrgroup.com

