

RD

RIDUTTORI AD INGRANAGGI

- due e tre coppie di ingranaggi cilindrici
- versione con piedi e piedi/flangia



HELICAL GEARBOXES

- two and three gear stages
- foot- and foot/flange version

STIRNRADGETRIEBE

- Zwei- u. Dreistufig
- Fuß- u. Fuß/Flansch-Ausführung



INDICE 	CONTENTS 	INDEX 
Modularità2-3	Modular system.....2-3	Modularsystem2-3
Descrizione.....4-6	Description.....4-6	Beschreibung.....4-6
Simboli.....7	Symbols.....7	Symbole.....7
Giunto8	Coupling.....8	Kupplung8
IEC - Flange & Giunto.....9	IEC - Flanges & coupling.....9	IEC - Flansch u. Kupplung9
NEMA - Flange & Giunto.....10	NEMA - Flanges & coupling10	NEMA - Flansch u. Kupplung10
Designazione riduttore11	Gearbox designation11	Bezeichnungen des Getriebes11
Catalogo elettronico VARsize.....12	VARsize electronic catalogue.....12	Elektronischer Katalog VARsize..12
Tappi di sfiato12	Breather plugs.....12	Entlüftungsventile.....12
Posizioni di montaggio13	Mounting positions13	Einbaulage.....13
Fattori di servizio.....14-16	Service factors14-16	Betriebsfaktoren.....14-16
Carichi esterni.....17	External loads17	Außere Belastungen17
Tabelle di Selezione	Selection tables	Auswahltabelle
Versioni.....18	Versions.....18	Ausführungen18
Potenza termica19	Thermal power19	Thermische Nennleistung19
FRD - SRD - RD20-26	FRD - SRD - RD20-26	FRD -SRD - RD20-26
MRD27-50	MRD27-50	MRD27-50
Dimensioni	Dimensions	Abmessungen
Motori IEC.....51	IEC Motors.....51	IEC-Motoren51
RD 02-0352	RD 02-0352	RD 02-0352
RD 12-1353	RD 12-1353	RD 12-1353
RD 22-2354	RD 22-2354	RD 22-2354
RD 32-3355	RD 32-3355	RD 32-3355
RD 42.4356	RD 42.43.....56	RD 42.4356
RD 52-5357	RD 52-5357	RD 52-5357
RD 62-6358	RD 62-6358	RD 62-6358
Informazioni generali	General information	Allgemeine Informationen
Rotazione e Parti componenti59	Rotation and Component parts.....59	Drehrichtung u. Bauelemente.....59
Standard motori elettrici60	Electric motor standards.....60	E-Motoren Standards.....60
Riepilogo ATEX61-63	ATEX summing-up61-63	ATEX Zusammenfassung61-63
Uso e Manutenzione64	Operation and Maintenance64	Betriebs u. Wartungsanweisung..64



Sistema modulare - Modular System - Modularsystem

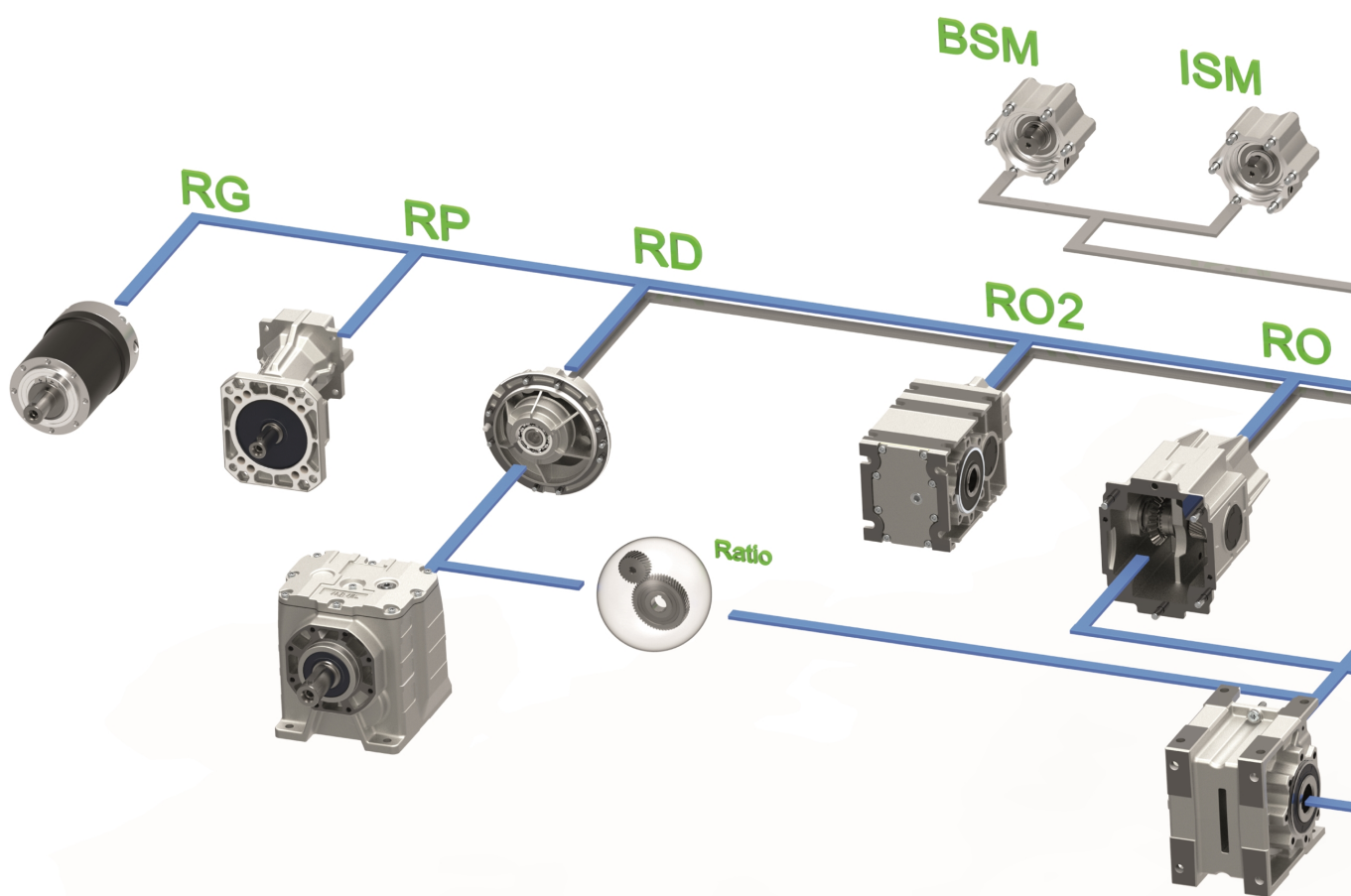

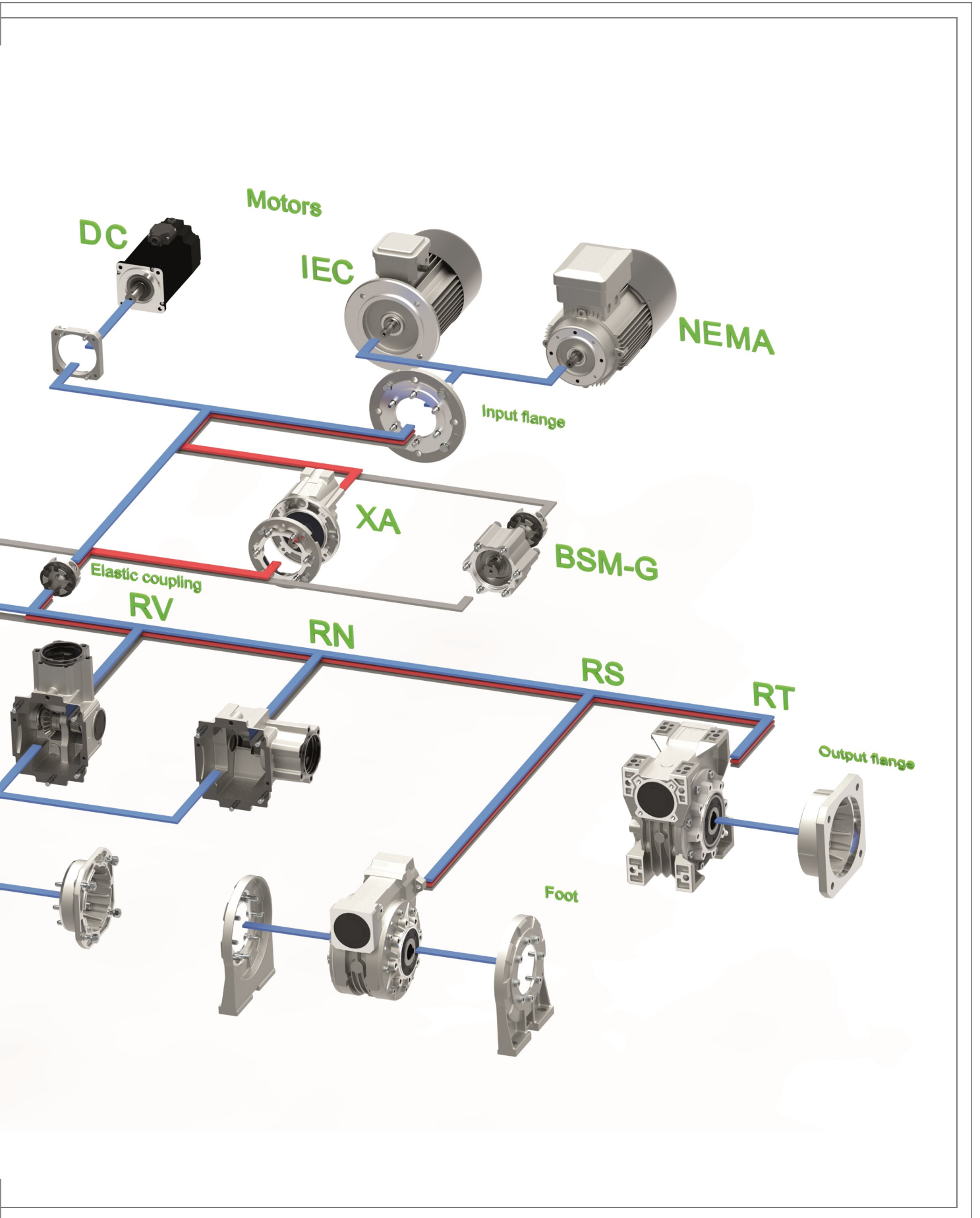



Descrizione - Description - Beschreibung

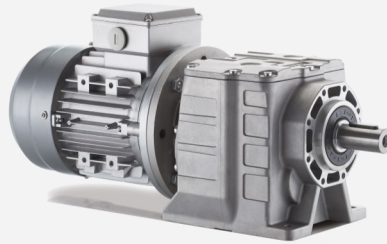

La serie dei riduttori a ingranaggi tipo RD, costruita con carcassa fusa in unico pezzo e con supporto interno per alloggiare 2 o 3 coppie di ingranaggi, è costruita secondo le norme di progettazione ISO e con l'ausilio di programma di analisi strutturale per verifica della deformata e dello stress.

La struttura monolitica della carcassa non subisce deformazioni significative sotto effetto della coppia di funzionamento e dei carichi esterni con positivi risultati sulle superfici di tenuta.

I riduttori serie RD sono costruiti con carcassa realizzata sempre in forma B3 con piedi, ma predisposta per la conversione in forma B5 utilizzando semplicemente una delle diverse flange di uscita disponibili.

La lavorazione in unico piazzamento con linee di produzione CNC dell'ultima generazione e i più moderni processi di calcolo e controllo originano una superiore affidabilità di funzionamento, le massime coppie disponibili, elevati carichi radiali ed assiali e lunga vita operativa.

I motori IEC o NEMA, come i motori cc e servomotori, sono facilmente montati con flange e giunti elastici di collegamento intercambiabili.

Il giunto elastico, contenuto all'interno del corpo riduttore, non comporta aumenti dimensionali nella lunghezza del riduttore

Direttiva ATEX

I riduttori VARVEL-ATEX, forniti su richiesta, sono costruiti secondo la Direttiva Europea 2014/34/UE-ATEX e pertanto, sono qualificati per installazione in atmosfere potenzialmente esplosive.

Dettagliate informazioni a pagina 61.

The helical gearboxes Series RD feature a one-piece cast housing complete with internal support to accommodate 2 or 3 gear stages into the same casing. Manufactured to latest ISO engineering design specifications the housing is checked by computer-aided structural analysis for deflection and stress distribution.

Significant strains caused by the effects of torque and external loads do not deflect the monolithic rib work of the housing, which significantly improves the integrity of the sealed surfaces.

RD gearboxes are manufactured in B3 foot-mounted configuration. They can be easily converted to a flange mounting by fitting the appropriate flange.

Single-setup machining on state-of-the-art CNC production lines, the most recent calculation techniques and process controls give superior operational reliability, maximum output torques, high overhung and thrust load capacity, and long working life-time.

IEC or NEMA motors, as well as dc-motors and servomotors, are easily mounted by fitting interchangeable bolted flanges and elastic couplings.

The elastic coupling, built-in inside the gearbox body, does not affect any dimensional length increase of the gearbox.

Directive ATEX

The gearboxes VARVEL-ATEX, supplied on demand, are manufactured according to the European Directive 2014/34/UE-ATEX and therefore, they are qualified for installation in potentially explosive atmospheres.

Detailed information at page 61.

Die Stirnradgetriebe die Baureihe RD besitzen ein einteiliges Gussgehäuse, welches die Aufnahme von 2 oder 3 Getriebestufen im gleichen Gehäuse ermöglicht. Die Entwicklung erfolgte nach den neuesten ISO-Vorschriften unter Berücksichtigung von Strukturanalysen zur Überprüfung der Verformungs-Beständigkeit.

Durch Drehmomente und einwirkende äußere Belastungen entstehen keine beachtenswerten Verspannungen des monolithischen Gehäuses mit Einfluss auf die Dichtflächen.

Die Gehäuse sind immer in Bauform B3 ausgeführt mit entsprechender Vorbereitung für Umrüstung in Bauform B5, wobei hier verschiedene Flansche zur Verfügung stehen.

Durch Zusammenfassung modernster Maschinen in CNC-Produktionslinien, durch fortschrittlichste Berechnungsverfahren und durch permanente Kontrolle der Produktion werden höchste Zuverlässigkeit, große Drehmomente, hohe Achsbelastbarkeit und Stoss-festigkeit bei langer Lebensdauer erreicht

IEC- und NEMA-Motoren, wie Gleichstrommotoren und Servomotoren, können mittels der austauschbaren Flansche und Kupplungen einfach montiert werden. Durch die integrierten Kupplungen tritt keine Veränderung der Länge des Antriebes auf.

Richtlinie ATEX

VARVEL-ATEX-Getriebe, die auf Anfrage geliefert werden, sind gemäß der Europäischen Richtlinie 2014/34/EU-ATEX gebaut und daher für den Einbau in explosionsfähige Atmosphären qualifiziert.

Detaillierte Informationen auf der Seite 61.

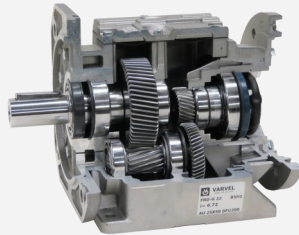
Descrizione - Description - Beschreibung

Fattore di servizio

I dati di selezione sono intesi per un fattore di servizio SF1.0, cioè per

- 8 ore di funzionamento al giorno
- carico uniforme
- 6 avviamenti all'ora
- temperatura ambiente fra 15 a 35 °C

Potenza termica

La **potenza nominale** P_1 , è la potenza che può essere applicata all'entrata del riduttore, in servizio continuo, temperatura max. ambiente di 40 °C, altitudine max. 1000 m e velocità dell'aria 1,25 m/s, senza superare una temperatura dell'olio di circa 85 °C.

La **potenza termica** P_{t1} può limitare la nominale P_1 (area in grigio, v. pagina 19) in funzione del sistema di raffreddamento, della velocità di entrata, della temperatura ambiente e del coefficiente di servizio.

Paraoli

- NBR - montati su alberi entrata e uscita, come standard,
- Viton - montati per funzionamento con motori 2-poli AC, DC e servo, a richiesta.
- Silicone - montati per funzionamento a basse temperature, a richiesta.

Lubrificante

I riduttori sono forniti riempiti di olio sintetico a lunga durata (ISO VG 320) per temperature -15/+35 °C.

Le quantità d'olio sono valide per le diverse posizioni di montaggio.

Tappi olio e di sfiato sono forniti su richiesta (v. pag. 12).

Dimensioni

Le dimensioni e le unità di misura sono riferite al sistema metrico o imperiale quando specificato.

Service factor

Selection data are intended for service factor SF1.0. i.e. for

- 8 running hours per day,
- uniform load,
- 6 start/stops per hour and
- room temperature from 15 to 35 °C

Thermal power

Rated power (P_1) is the power that can be applied at the gearbox input, on continuous operation, max. temperature of 40 °C, max. altitude of 1000 m and air speed of 1.25 m/s, without exceeding the oil temperature of about 85 °C.

Thermal power (P_{t1}) can limit the rated P_1 (shaded area, see page 19) depending on the cooling system, input speed, ambient temperature and service factor.

Oil seals

- NBR - fitted on input and output shafts as standard.
- Viton - for operation with 2-pole AC, DC and servo motors, on demand.
- Silicone - for low temperature operation, on demand.

Lubricant

Gearboxes are delivered filled with synthetic long-life oil (ISO VG 320 Grade) for temperature -15/+35 °C as standard.

Oil quantities are valid for any working positions.

Oil, drain or vent plugs on demand (see page 12).

Dimensions

Dimensions and units of measurement are referred to the metric system or imperial when stated.

Betriebsfaktor

Die Auswahldaten sind für einen SF1.0-Leistungsfaktor bestimmt, d.h. für:

- 8-Betriebsstunden pro Tag
- gleichmäßige Belastung
- 6 Starts pro Stunde
- Raumtemperatur zwischen 15 und 35°C

Thermische Leistung

Die **Nennleistung** (P_1) ist die Leistung, die am Getriebe angewendet werden kann, Dauerbetriebstemperatur von 40 °C max., max. Höhe 1000 m und Luftgeschwindigkeit von 1,25 m/s, ohne mehr als eine Temperatur von Öl von etwa 85 °C.

Die **thermische Leistung** (P_{t1}) kann der Nennleistung P_1 (Schattiert Zone, sehen auf Seite 19) als Funktion des Kühlsystems der Antriebsdrehzahl, Umgebungstemperatur und der Koeffizient der Service begrenzen.

Dichtringe

- NBR - werden als Standard an den Ein- und Ausgangswellen montiert.
- Viton - für Betrieb mit 2-Pole Wechselstrom-, Gleichstrom- und Servomotoren, auf Anfrage.
- Silikon - für niedrige Temperaturen, auf Anfrage.

Schmierung

Die Getriebe werden mit langlebigem synthetischem Öl (ISO VG 320) für Temperaturen bei -15/+35 °C beliefert. Die Ölmenge gilt für verschiedene Montagepositionen.

Öl- und Entlüftungsventile sind auf Anfrage erhältlich (siehe Seite 12).

Dimensionen

Die Abmessungen und Maßeinheiten beziehen sich auf das metrische System oder imperiale wenn angegeben.

Descrizione - Description - Beschreibung

	Specifiche generali	General specifications	Allgemeine Eigenschaften
Gamma Range Bereich	7 grandezze 28 rapporti in 2 e 3 coppie 2100 Nm coppia uscita max.	7 sizes 28 reduction ratios, 2 and 3 stages 2100 Nm max. output torque	7 Baugrößen 28 Übersetzungen 2- u. 3-stufig 2100 Nm max. Abtriebsmoment
Dimensionamento Sizing Auslegung	Secondo ISO6336 / DIN3990.	According to ISO6336/DIN3990.	Laut ISO6336/DIN3990.
Carcassa, Coperchi Housing, Covers Gehäuse, Flansche	Pressofusione in alluminio fino alla taglia 4 Ghisa dalla taglia 5	Aluminium die cast up to size 4 Cast iron from size 5	Aluminium-Druckguss bis Größe 4 Grauguss ab Größe 5
Giunto Coupling Kupplung	Pressofusione in alluminio o acciaio a richiesta fino a G6 Acciaio per G8	Aluminium die cast, or steel alloy on demand, up to G6 Alloy steel for G8	Aluminium-Druckguss oder Stahl auf Anfrage bis G6 Stahl für G8
Parti dentate Toothed parts Verzahnung	Acciaio cmt / tmp Evolvente rettificato / sbarbato	Case hardened steel Ground / shaved tooth profile	Stahl einsatzgehärtet Zahnprofil geschliffen / rasiert
Cuscinetti Bearings Lagerung	Sfere / rulli secondo grandezza e specifiche tecniche	Ball- / roller-types according to sizes and technical requirements	Kugel- / Rollenlager entsprechend den technischen Vorschriften
Paraolio Oil seals Dichtungen	NBR - Nitril-Butadiene Rubber con secondo labbro parapolvere secondo DIN 3760 VIT - Polimero fluorurato Viton a richiesta SIL - Silicone a richiesta	NBR - Nitril-Butadiene Rubber with additional anti-dust lip according to DIN 3760 VIT - Viton Fluorinated rubber on demand SIL - Silicone rubber on demand	NBR - Nitril-Butadien Rubber mit zusätzlicher Staublippe entsprechend DIN 3760 VIT - Fluorelaste Viton auf Anfrage SIL - Silikon auf Anfrage
Lubrificante Lubricant Schmierung	Olio sintetico a lunga durata Gradazione ISO VG 320	Synthetic long-life oil Grade ISO VG 320	Synthetisches Getriebeöl ISO VG 320 als Langzeit-Füllung
Verniciatura Painting Gehäuselackierung	Alluminio naturale fino taglia 4 Vernice a polveri epossidiche colore RAL 7012 dalla taglia 5	Uncoated aluminium up to size 4 . Epoxy powder paint Standard colour RAL 7012 from size 5	Natürliches Aluminium bis Größe 4 Epoxydpulverfarbe Standard-farbtone RAL 7012 ab Größe 5
Grado di protezione Protection grade Schutzgrad	IP66 - Solo corpo del riduttore IP20 - Riduttore con flange e collegamenti Protezioni aumentate su richiesta	IP66 - Gearbox body only IP20 - Gearbox with flanges and adapters: Increased grades on demand	IP66 - Nur Getriebebeskörper IP20 - Getriebe mit Verbindungsflansche Schutzart erhöht nach Anfrage
ATEX	A richiesta	On demand	Auf Anfrage

Simboli - Symbols - Symbole

	Simboli	Symbols	Symbole
D	[mm] Diametro primitivo dell'elemento di trasmissione k_T	PCD of transmission element k_T	Wirkkreisdurchmesser des Übertragungselementes k_T
F_{r1} , F_{r2} , F_r	[N] Carico radiale di catalogo (entrata, uscita, applicazione)	Catalogue radial load (input, output, application)	Radialbelastung aus dem Katalog (Eingang, Ausgang, Anwendung)
SF	Fattore di servizio	Service factor	Betriebsfaktor
i , i_r	Rapporto di riduzione (nominale, reale)	Reduction ratio (nominal, real)	Übersetzung (nominal, reell)
J_1 , J_2 , J_m	[kgm ²] Momento d'inerzia del riduttore (entrata, uscita) e del motore	Moment of inertia of the gearbox (input, output) and of motor	Trägheitsmoment des Getriebes (Eingang, Ausgang) u. des Motor
k_a , k_L , k_T , k_{S3}	Fattore (accelerazione, lunghezza, tipo, intermittenza S3)	Factor (acceleration, length, type, S3 intermittenza)	Faktor (Beschleunigung, Länge, Typ, S3-Intermittenz)
Lub H, V	[l] Lubrificante (litri) Montaggio (orizzontale, verticale)	Lubricant (litres) Mounting (horizontal, vertical)	Schmierstoff (Liter) Einbaulage (waagrechte, senkrechte)
M_2 , $M_{(app)}$	[Nm] Coppia massima di uscita (riduttore, applicazione)	Maximum output torque (gearbox, application)	Abtriebsdrehmoment (Getriebe, Anwendung)
n_1 , n_2	[rpm] Velocità (entrata, uscita)	Speed (input, output)	Drehzahl (Eingang, Ausgang)
P_1	[kW] Potenza (entrata)	Power (input)	Leistung (Eingang)
Peso Weight Gewicht	[kg] Pesi di catalogo (per montaggio B3H e rapporto di riduzione medio)	Catalogue weights (for B3H mounting and average reduction ratio)	Katalogsgewichte (für B3H-Bauform und durchschnittliche Getriebeübersetzung)
η (0.96, 0.94)	Rendimento (2 coppie, 3 coppie)	Efficiency (2 gear trains, 3 gear trains)	Wirkungsgrad (2-Stufen, 3-Stufen)
	Formule utili	Useful formulae	Nützliche Formeln
$P_1 = \frac{M_2 * n_2}{9550 * \eta}$	Potenza entrata [kW]	Input power [kW]	Eingangsleistung [kW]
$M_2 = \frac{9550 * P_1 * \eta}{n_2}$	Coppia uscita [Nm]	Output torque [Nm]	Ausgangsdrehmoment [Nm]
$FS = \frac{M_2}{M_{(app)}}$	Fattore di servizio	Service factor	Betriebsfaktor



Giunto - Coupling - Kupplung

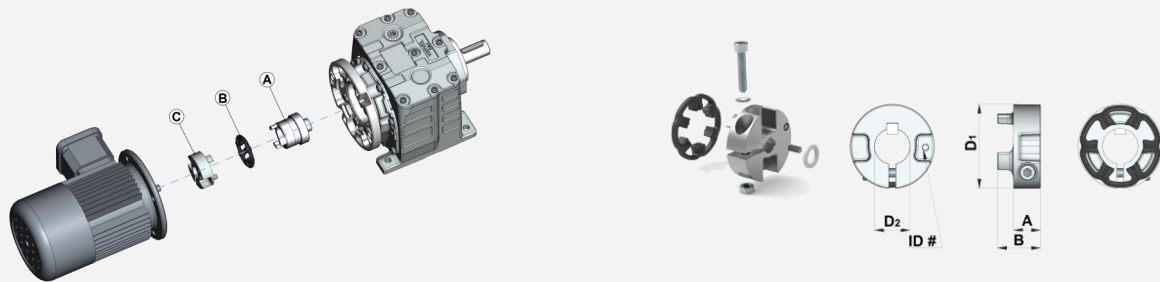

Vantaggi:

- Giunto con serraggio a morsetto per attrito sull'albero motore
- Flange e giunti per motori IEC/NEMA montabili sul riduttore finito
- Eliminazione sfregamento fra foro e chiavetta (tribocorrosione)
- Gioco zero nel collegamento riduttore/ motore
- Disallineamento angolare ammesso <1°
- Elevata rigidità torsionale

Advantages:

- Friction clamped coupling on motor shaft
- IEC/NEMA adapters and couplings fitted on already assembled gearbox
- Elimination of fretting corrosion between bore and key
- Zero backlash in gearbox/motor connection
- Angular allowed misalignment smaller than 1°
- High torsional rigidity

Vorzüge:

- Kupplung mit Reibungsklemmung auf dem Motorwelle
- IEC/NEMA Flanschen und Kupplungen auf dem fertigem Getriebe montierbar
- Vermeidung von Passungsost zwischen Bohrung u. Keil
- Getriebe / Motor Spielfrei Verkeilung
- Zulässige Winkelausgleich unter 1°
- Hohe Verdrehsteifigkeit

Motore Motor	Tipo Type Typ	Codice Kit Kit Part No. Kit Teil Nr.	RD	Mt [Nm]	Mt ₁ [Nm]	Mt ₂ [Nm]	A [mm]	B [mm]	D ₁ [mm/ inch]	D ₂ [mm/ inch]	ID#
IEC	G3	KG3.009	03	4.5 - 6	15	8 - 10	11	19	30	9	309
		KG3.011		4.5 - 6	15	8 - 10			30	11	311
		KG3.014		7 - 8.5	28	18 - 22			36	14	314
	G5	KG5.009	02-12-13-23	8.9 - 10	14	8 - 10	14.5	23	45	9	509
		KG5.011	02-12-13-23		15	8 - 10			45	11	511
		KG5.014	02-12-13-23		30	12 - 17			45	14	514
		KG5.019	02-12-23		40	20 - 25			45	19	519
	G6	KG5.024	12-23	15.3 - 18	70	30 - 40	19.5	31.5	52	24	524
		KG6.014	22-32-33-42-43		60	30 - 40			14	614	
		KG6.019	22-32-33-42-43		90	50 - 65			19	619	
		KG6.024	22-32-33-42-43		130	85 - 100			24	624	
	GS8*	KG6.028	22-32-42	15	180	100 - 120	35	51	28	28	628
KGS8.19		52-53-62-63	150		---	19			819		
KGS8.24		52-53-62-63	250		---	24			824		
KGS8.28		52-53-62-63	350		---	28			828		
GS8*	KGS8.38	52-62-63	15	500	---	35	51	38	38	838	
	KGS8.42	52-62		500	---			42	842		
	KGS8.48	52-62		500	---			48	848		
	KGS8.48	52-62		500	---			48	848		

Motore Motor	Tipo Type Typ	Codice Kit Kit Part No. Kit Teil Nr.	RD	Mt [in-lb]	Mt ₁ [in-lb]	Mt ₂ [in-lb]	A [in]	B [in]	D ₁ [in]	D ₂ [in]	ID#
NEMA	G3	KG3.N42	03	4.5 - 6	16	8 - 10	11	19	30	3/8"	3N42
		KG3.N48		4.5 - 6	18	10 - 12			36	1/2"	3N48
	G5	KG5.N48	02	8.9 - 10	30	20 - 24	14.5	23	40	1/2"	5N48
		KG5.N56	02-12-13-23		45	30 - 35			45	5/8"	5N56
		KG5.N140	12-23		60	40 - 45			52	7/8"	5N140
	G6	KG6.N56	22-32-33-42-43	15.3 - 18	50	---	19.5	31.5	58	5/8"	6N56
		KG6.N140	22-32-33-42-43		85	---			7/8"	6N140	
		KG6.N180	22-32-42-43		200	---			1-1/8"	6N180	
	GS8*	KGS8.N056	52-53-62-63	15	140	---	35	51	79	5/8"	8N56
		KGS8.N140	52-53-62-63		200	---			7/8"	8N140	
		KGS8.N180	52-53-62-63		300	---			1-1/8"	8N180	
		KGS8.N210	52-53-62-63		500	---			1-3/8"	8N210	

Mt - Coppia di serraggio vite
 Mt₁ - Coppia trasmissibile con chiavetta
 Mt₂ - Coppia trasmissibile senza chiavetta

Mt - Screw locking torque
 Mt₁ - Transmissible torque with key
 Mt₂ - Transmissible torque without key

Mt - Klemmendrehmoment der Schraube
 Mt₁ - übertragbar Drehmoment mit Keil
 Mt₂ - übertragbar Drehmoment ohne Keil

IEC - Flange e Giunto - Flanges & Coupling - Flansche u. Kupplung
RD

Tipo Riduttore Gearbox Size Getriebestyp	Tipo - Type - Typ	Flangia - Flange - Flansch			Giunto - Coupling - Kupplung	
		IEC	Codice - Part No. - Teil Nr. Kit B5 Kit B14		Tipo - Type - Typ	Kit Part No.
RD 02	FM 40	56	K531.206.120	K531.206.080	G5 ø9	KG5.009
		63	K531.206.140	K531.206.090	G5 ø11	KG5.011
		71	K531.206.160	K531.206.105	G5 ø14	KG5.014
		80	---	K531.206.120	G5 ø19	KG5.019
RD 03	FM 40	56	K531.206.120	K531.206.080	G3 ø9	KG3.009
		63	K531.206.140	K531.206.090	G3 ø11	KG3.011
		71	K531.206.160	K531.206.105	G3 ø14	KG3.014
RD 12	FM 50	56	K532.206.120	---	G5 ø9	KG5.009
		63	K532.206.140	K532.206.090	G5 ø11	KG5.011
		71	K532.206.160	K532.206.105	G5 ø14	KG5.014
		80	K532.206.200	K532.206.120	G5 ø19	KG5.019
		90	K532.206.200	K532.206.140	G5 ø24	KG5.024
RD 13	FM 50	56	K532.206.120	---	G5 ø9	KG5.009
		63	K532.206.140	K532.206.090	G5 ø11	KG5.011
		71	K532.206.160	K532.206.105	G5 ø14	KG5.014
RD 22	FM 70	71	K533.206.160	K533.206.105	G6 ø14	KG6.014
		80	K533.206.200	K533.206.120	G6 ø19	KG6.019
		90	K533.206.200	K533.206.140	G6 ø24	KG6.024
		100/112	K533.206.250	K533.206.160	G6 ø28	KG6.028
RD 23	FM 70	63	K533.206.140	---	G5 ø11	KG5.011
		71	K533.206.160	K533.206.105	G5 ø14	KG5.014
		80	K533.206.200	K533.206.120	G5 ø19	KG5.019
RD 32	FM 70	71	K533.206.160	K533.206.105	G6 ø14	KG6.014
		80	K533.206.200	K533.206.120	G6 ø19	KG6.019
		90	K533.206.200	K533.206.140	G6 ø24	KG6.024
		100/112	K563.206.250	K533.206.160	G6 ø28	KG6.028
RD 33	FM 70	71	K533.206.160	K533.206.105	G6 ø14	KG6.014
		80	K533.206.200	K533.206.120	G6 ø19	KG6.019
		90	K533.206.200	K533.206.140	G6 ø24	KG6.024
		100	K563.206.250	K533.206.160	G6 ø28	KG6.028
RD 42	FM 85	80	K534.206.200	K534.206.120	G6 ø19	KG6.019
		90	K534.206.200	K534.206.140	G6 ø24	KG6.024
		100/112	K534.206.250	K534.206.160	G6 ø28	KG6.028
		132	K564.206.300	K534.206.200	G6 ø38	KG6.038
RD 43	FM 85	71	K534.206.160	---	G6 ø14	KG6.014
		80	K534.206.200	K534.206.120	G6 ø19	KG6.019
		90	K534.206.200	K534.206.140	G6 ø24	KG6.024
		100	K534.206.250	K534.206.160	G6 ø28	KG6.028
RD 52	FM 130 & FM 150	90	K536.206.200	---	* GS8 ø24	KGS8.024
		100/112	K536.206.250	---	* GS8 ø28	KGS8.028
		132	K537.206.300	K536.206.200	* GS8 ø38	KGS8.038
		160	K565.206.350	---	* GS8 ø42	KGS8.042
RD 53	FM 130 & FM 150	80	K536.206.200	---	* GS8 ø19	KGS8.019
		90	K536.206.200	---	* GS8 ø24	KGS8.024
		100/112	K536.206.250	---	* GS8 ø28	KGS8.028
		132	K537.206.300	K536.206.200	* GS8 ø38	KGS8.038
RD 62	FM 130 & FM 150	90	K536.206.200	---	* GS8 ø24	KGS8.024
		100/112	K536.206.250	---	* GS8 ø28	KGS8.028
		132	K537.206.300	K536.206.200	* GS8 ø38	KGS8.038
		160	K565.206.350	---	* GS8 ø42	KGS8.042
		180	K565.206.350	---	* GS8 ø48	KGS8.048
RD 63	FM 130 & FM 150	80	K536.206.200	---	* GS8 ø19	KGS8.019
		90	K536.206.200	---	* GS8 ø24	KGS8.024
		100/112	K536.206.250	---	* GS8 ø28	KGS8.028
		132	K537.206.300	K536.206.200	* GS8 ø38	KGS8.038
		160	K565.206.350	---	* GS8 ø42	KGS8.042

* - Giunto GS8: montaggio con chiavetta e grano di bloccaggio assiale

* - Coupling GS8: key fitting and axial locking grub screw

* - Kupplung GS8: Keilmontage u. gewindestift



NEMA - Flange e Giunto - Flanges & Coupling - Flansche u. Kupplung

Tipo Riduttore Gearbox Type Getriebetyp	Flangia - Flange - Flansch			Giunto - Coupling - Kupplung	
	Tipo - Type - Typ	NEMA	Kit Part No.	Tipo - Type - Typ	Kit Part No.
RD 02	FM 40	48 C 56 C	K531.227.N48 K531.227.N56	G5 ø 1/2" G5 ø 5/8"	KG5.N48 KG5.N56
RD 03		42 C 48 C	K531.227.N48 K531.227.N48	G3 ø 3/8" G3 ø 1/2"	KG3.N42 KG3.N48
RD 12	FM 50	56 C 140 TC	K532.227.N56 K532.227.N56	G5 ø 5/8" G5 ø 7/8"	KG5.N56 KG5.N140
RD 13		56 C	K532.227.N56	G5 ø 5/8"	KG5.N56
RD 22	FM 70	56 C 140 C 180 C	K533.227.N56 K533.227.N56 K533.227.N180	G6 ø 5/8" G6 ø 7/8" G6 ø 1-1/8"	KG6.N56 KG6.N140 KG6.N180
RD 23		56 C 140 C	K533.227.N56 K533.227.N56	G5 ø 5/8" G5 ø 7/8"	KG5.N56 KG5.N140
RD 32	FM 70	56 C 140 TC 180 TC	K533.227.N56 K533.227.N56 K533.227.N180	G6 ø 5/8" G6 ø 7/8" G6 ø 1-1/8"	KG6.N56 KG6.N140 KG6.N180
RD 33		56 C 140 TC	K533.227.N56 K533.227.N56	G6 ø 5/8" G6 ø 7/8"	KG6.N56 KG6.N140
RD 42	FM 85	56 C 140 TC 180 TC	K534.227.N56 K534.227.N56 K534.227.N180	G6 ø 5/8" G6 ø 7/8" G6 ø 1-1/8"	KG6.N56 KG6.N140 KG6.N180
RD 43		56 C 140 TC 180 TC	K534.227.N56 K534.227.N56 K534.227.N180	G6 ø 5/8" G6 ø 7/8" G6 ø 1-1/8"	KG6.N56 KG6.N140 KG6.N180
RD 52	FM 150	56 C 140 TC 180 TC 210 TC	K537.227.N56 K537.227.N56 K537.227.N180 K537.227.N180	* GS8 ø 5/8" * GS8 ø 7/8" * GS8 ø 1-1/8" * GS8 ø 1-3/8"	KGS8.N56 KGS8.N140 KGS8.N180 KGS8.N210
RD 53		56 C 140 TC 180 TC 210 TC	K537.227.N56 K537.227.N56 K537.227.N180 K537.227.N180	* GS8 ø 5/8" * GS8 ø 7/8" * GS8 ø 1-1/8" * GS8 ø 1-3/8"	KGS8.N56 KGS8.N140 KGS8.N180 KGS8.N210
RD 62	FM 150	56 C 140 TC 180 TC 210 TC	K537.227.N56 K537.227.N56 K537.227.N180 K537.227.N210	* GS8 ø 5/8" * GS8 ø 7/8" * GS8 ø 1-1/8" * GS8 ø 1-3/8"	KGS8.N56 KGS8.N140 KGS8.N180 KGS8.N210
RD 63		56 C 140 TC 180 TC 210 TC	K537.227.N56 K537.227.N56 K537.227.N180 K537.227.N210	* GS8 ø 5/8" * GS8 ø 7/8" * GS8 ø 1-1/8" * GS8 ø 1-3/8"	KGS8.N56 KGS8.N140 KGS8.N180 KGS8.N210
		* - Giunto GS8: serraggio con chiave e grano di bloccaggio assiale	* - Coupling GS8: key fitting and axial locking grub screw	* - Kupplung GS8: Keilmontage u. gewindestift	

Designazione - Designation - Bezeichnungen

Designazione del riduttore							Designation of the gearbox			Bezeichnung des Getriebes
F	RD	-G - - -	32	/B3	H	31.5	IEC71	B14	AU30	DFU200
<p> ø - Flangia uscita - Output flange - Ausgangsflansch ø - Albero uscita - Output shaft - Ausgangswelle Forma del motore - Motor form - Motorbauform Grandezza del motore elettrico - Electric motor frame - Motorbaugröße Rapporto di riduzione - Reduction ratio - Getriebeübersetzung Posizione di montaggio del riduttore - Gearbox mounting position - Einbaulage des Getriebes Forma costruttiva del riduttore - Gearbox form - Bauform des Getriebes Grandezza e coppie del riduttore - Gearbox size and stages - Baugröße u. Stufen des Getriebes -G = Entrata con giunto G - Input with G coupling - Eingang mit G-Kupplung - - - = Entrata con foro & chiavetta - Input with key & keyway - Eingang mit Bohrung u. Keil Tipo del riduttore - Gearbox type - Getriebetyp </p>										
M = Motoriduttore F = Riduttore con entrata IEC S = Riduttore senza flangia entrata IEC ... = (nulla) Riduttore con albero entrata sporgente			- Geared motor - Gearbox with input flange - Gearbox without input flange - (nothing) Gearbox with input free shaft			- Getriebemotor - Getriebe mit Eingangsflansch - Getriebe ohne Eingangsflansch - (Nichts) Freie Eingangswelle				
Designazione del motore				Designation of the motor				Bezeichnung des Motors		
MT	0.37 kW	71 B	4	B14	230/400/50	IP55	F	X4		
<p> Posizione della morsettiera Terminal box position Klemmkastenposition Classe isolamento Insulation class Isolationsklasse Grado di protezione - Protection class - Schutzart Tensione / Frequenza - Voltage/frequency - Spannung/Frequenz Forma costruttiva - Mounting form - Bauform Numero poli - Number of poles - Polzahl Grandezza IEC del motore - IEC motor frame - IEC-Motorbaugröße Potenza del motore - Motor power - Motorleistung </p>										
MT = Motore trifase MM = Motore monofase MA = Motore autofrenante			- Three-phase motor - Single-phase motor - Brake motor			- Dreiphasenmotor - Einphasenmotor - Bremsmotor				
<div style="text-align: right;"> </div>										



<p>Modularità e la flessibilità hanno guidato il progetto dei prodotti VARVEL fino dagli anni 2000 permettendo così, la disponibilità di riduttori in kit con montaggio in pochi minuti utilizzando una normale attrezzatura. Questo permette la massima flessibilità ai distributori e rivenditori VARVEL che, grazie ad un numero limitato di elementi, possono configurare all'istante il prodotto richiesto dai clienti. Il programma di selezione VARsize® disponibile nel sito web www.varvel.com permette un facile dimensionamento dei prodotti VARVEL.</p> <p>Disegni 2D/3D Tramite configurazione assistita si generano modelli 3D e disegni 2D nei formati CAD più diffusi.</p> <p>Configurazione assistita Identifica, fra tutte le serie, i riduttori che sono adeguati per soddisfare i parametri di funzionamento richiesti (potenza, coppia, velocità, fattore di servizio, ecc.). Definita la grandezza del riduttore, un documento è generato dai dati della richiesta, così come il disegno dimensionale PDF, il modello 3D e il disegno 2D.</p>	<p>Modularity and flexibility have been leading the design of VARVEL products since the years 2000 thus allowing the availability of gearboxes in kit form with assembly in a few minutes using normal equipment. This feature provides the highest flexibility to VARVEL's distributors and resellers who - thanks to a limited kit selection - are able to immediately configure the required product. VARsize® selection program, available from our web-site www.varvel.com allows a friendly sizing of VARVEL product range.</p> <p>2D/3D Drawings A guided selection lets 2D/3D models downloaded for the most popular CAD systems.</p> <p>Guided selection This option returns a list of appropriate product configurations upon a given sequence of application parameters (power, output torque, rpm, service factor etc.); a PDF data sheet featuring performance data and dimensional drawings are generated for each configuration, as well as the 3D model and 2D drawings.</p>	<p>Bausteinprinzip und Flexibilität Sie bestimmen seit den 2000er Jahren das Design von VARVEL-Produkten somit die Verfügbarkeit von Getrieben in Kit Form ermöglichte die Montage mit einfachem Werkzeug in nur wenigen Minuten. Dies ermöglicht VARVEL-Händlern und Wiederverkäufern maximale Flexibilität, die Dank einer begrenzten Anzahl von Elementen das vom Kunden gewünschte Produkt sofort konfigurieren können. Das VARsize®-Auswahlprogramm finden Sie auf der Website www.varvel.com ermöglicht die einfache Dimensionierung von VARVEL-Produkten .</p> <p>2D/3D-Zeichnungen Die unterstützte Auswahl bietet die Möglichkeit 2D/3D Modelle für die gängigen CAD Systeme zu laden.</p> <p>Unterstützte Auswahl Mit diesem Dienst wird eine Liste möglicher Produktvarianten erzeugt, bestimmt durch Parameter (Leistung, Moment, Drehzahl, Betriebsfaktor usw.); ein PDF Datenblatt mit Leistungsdaten und Maßbild ist für jede dieser Konfigurationen verfügbar, ebenso wie 3D Modelle und 2D Zeichnungen.</p>
---	--	--

<p>Tappi di sfiato</p> <p>L'installazione del tappo di sfiato è raccomandato quando la pressione interna supera i valori di 0.25-0.3 bar per evitare possibili fuoriuscite di lubrificante dai paraolio.</p> <p>L'aumento della pressione interna è originata dalla variazione del volume del lubrificante causato dall'aumento della temperatura a fronte di condizioni</p> <ul style="list-style-type: none"> esterne (posizione di lavoro inclinata, ambiente maggiore di 35 °C), o interne (velocità di ingresso maggiore di 2000 rpm, frequenti avviamenti, servizio continuo oltre a 8 ore al giorno). <p>La taratura standard dello sfiato è 0.25-0.3 bar. Altre tarature su richiesta. Richiedere la fattibilità dell'installazione del tappo di sfiato in quanto non tutte le taglie dei riduttori lo permettono.</p>	<p>Breather plugs</p> <p>Breather plug installation is recommended when pressure exceeds 0.25-0.3 bar to avoid possible leakage of lubricant from the oil seal.</p> <p>Internal pressure increase is caused by lubricant volume variation due to temperature increase because of</p> <ul style="list-style-type: none"> external conditions (sloped working position, environment over 35°C), or internal conditions (input speed over 2000 rpm; frequent start/stops, continuous service over 8 hours a day). <p>Breather plug standard calibration is 0.25-0.3 bar. Other calibrations on demand. Ask for breather plug installation feasibility as not all the sizes allow it.</p>	<p>Entlüftungsventile</p> <p>Die Installation des Entlüftungsventil wird empfohlen, wenn der Innendruck 0.25-0.3 bar übersteigt, um ein Auslaufen von Schmiermitteln aus den Dichtungen zu vermeiden.</p> <p>Die Erhöhung des Innendrucks ergibt sich aus der Veränderung des Schmiervolumens verursacht unter bestimmten Temperatur Bedingungen, rein indikativ, wie</p> <ul style="list-style-type: none"> äußerer Bedingungen (gekippte Arbeitsposition, Umgebung mehr als 35 °C), oder inneren Bedingungen (Eingangsgeschwindigkeit mehr als 2000 UpM, häufige Start ups, durchgehender Dienst mehr als 8 Stunden pro Tag). <p>Die Standardkalibrierung der Entlüftung beträgt 0,25-0,3 bar. Andere Kalibrierungen auf Anfrage. Bitte fragen Sie nach der Durchführbarkeit des Entlüftungsventil, da dies nicht alle Getrieben erlauben.</p>
---	--	---

RD

- due e tre coppie
- two and three stages
- Zwei- u. Dreistufig

B3
Montaggio a piedi
Foot mounting
Fußbauformen

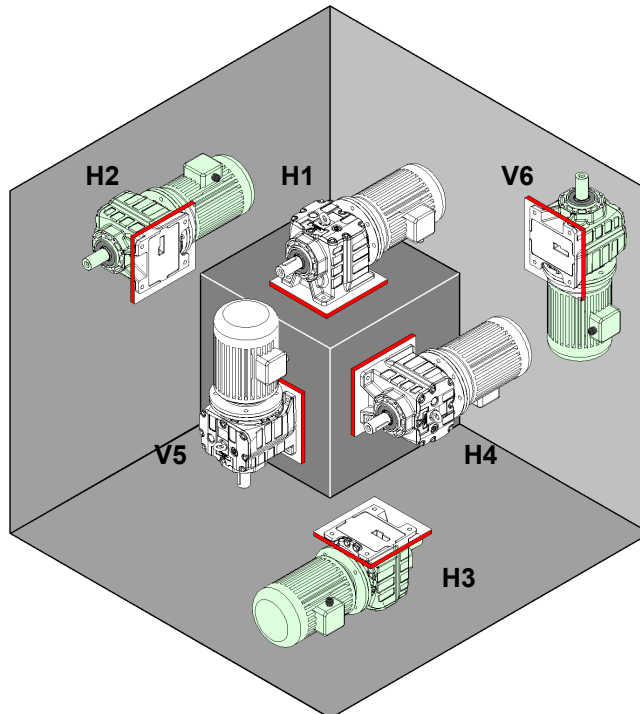

B5
Montaggio a flangia
Flange mounting
Flanschbauformen

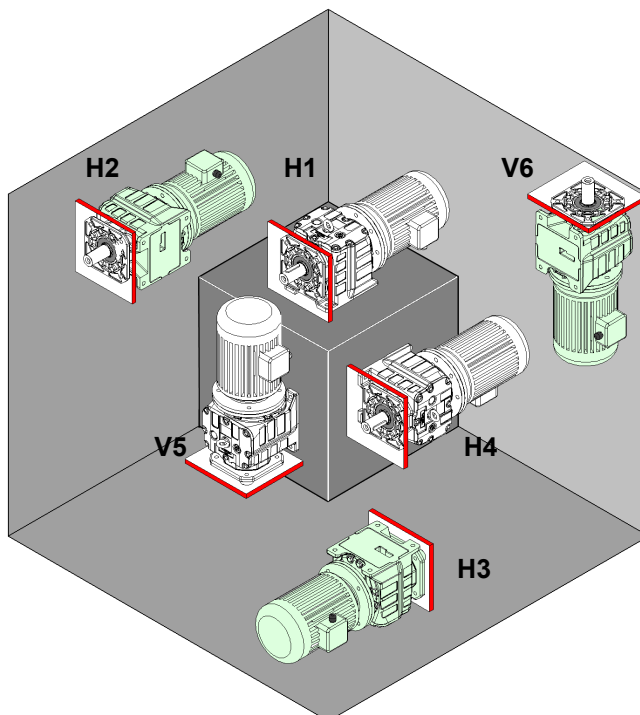



Fattori di servizio - Service factors - Betriebsfaktoren

Fattore di utilizzo del riduttore	Duty factor of the gearbox	Ausnutzungsfaktor des Getriebes
<p>Il rapporto fra la coppia massima di uscita M_2 del riduttore e la coppia richiesta dalla applicazione $M_{(app)}$ determina il Fattore di Utilizzo che deve essere uguale o superiore ai fattori SF o k_a qui definiti.</p> <p>Il Fattore di servizio è inteso SF1.0 come rappresentativo di un funzionamento di</p> <ul style="list-style-type: none"> • 8 ore al giorno • con carico uniforme, • avviamenti inferiori a 6 all'ora • temperatura ambiente fra 15 e 35 °C <p>altre condizioni di lavoro secondo le tabelle SF₁ e SF₂ qui sotto.</p> <p>Il Fattore di accelerazione delle masse è inteso $k_{(a)} \leq 0.2$ come rappresentativo di un funzionamento di 8 ore al giorno per Classe di carico A, altre condizioni di lavoro secondo i grafici della pagina seguente..</p> <p>Non è necessario tener conto della potenza termica (v. pag.19) quando la durata massima di servizio continuativo è di circa 3 h seguita da pause sufficienti (circa 2 - 4 h) a ristabilire nel riduttore la temperatura ambiente.</p> <p>Per temperatura massima ambiente maggiore di 35 °C oppure minore di 0 °C interpellare il Servizio Clienti.</p>	<p>The ratio between the gearbox maximum output torque M_2 and application torque $M_{(app)}$ defines the Duty Factor that must be equal or bigger than the Factors SF or k_a here defined.</p> <p>Service factor is meant SF1.0 as typical operation of</p> <ul style="list-style-type: none"> • 8 hours/day • with uniform load • starts/ stops lower than 6 per hour • ambient temperature between 15 and 35 Celsius, <p>according to SF₁ and SF tables below .</p> <p>Mass acceleration factor is meant $k_{(a)} \leq 0.2$ as typical operation of 8 hours/day for Load class A, other working conditions according to next page graphs.</p> <p>Thermal power (see page19) can be not considered when the max. continuous operation is about 3 hours with long enough rest periods (about 2 to 4 hours) to restore the ambient temperature into the gearbox.</p> <p>For max. ambient temperature exceeding 35 °C or below 0 °C. please ask our Customer Service.</p>	<p>Der Verhältnis zwischen dem Drehmoment des Getriebes M_2 und dem erfragtem Drehmoment der Anwendung $M_{(app)}$, bestimmt den Ausnutzungsfaktor, der gleich oder größer als die hier definierten Faktoren SF oder $k_{(a)}$ - sein muss.</p> <p>Der Servicefaktor gilt SF1.0 als repräsentativ für eine</p> <ul style="list-style-type: none"> • 8-stündiger Betrieb • mit gleichförmiger Last • bis zu 6 Schaltungen je Stunde • Umgebungstemperaturen zwischen 15° und 35 °C. <p>andere Arbeitsbedingungen nach untenstehender SF₁- und SF₂-Tabelle.</p> <p>Der Massenbeschleunigungs Faktor $k_{(a)} \leq 0.2$ gilt als repräsentativ für eine 8-stündiger Betrieb für A-Belastungsklasse, andere Arbeitsbedingungen nach den Grafiken der nächsten Seite.</p> <p>Das Verhältnis zwischen dem maximalen Thermische Leistung (siehe Seite 19) können nicht berücksichtigt. wenn die max. Dauerbetrieb etwa 3 Stunden lang genug Ruhezeiten (ca. 2 bis 4 Stunden). um die Umgebungstemperatur in dem Getriebe wiederherzustellen.</p> <p>Für max. Umgebungstemperatur über 35° C oder unter 0° C. fragen Sie bitte unseren Kundenservice.</p>

Fattore di Servizio SF				Service Factor SF		Betriebsfaktor SF
Tipo di carico Charge type Belastung-Typ				Avviamenti / ora Start-Stops / hour Schaltungen/Stunde		SF = SF ₁ x SF ₂
ore hours Stunden	uniforme uniform gleichmäßige SF ₁	variabile variable variabel SF ₁	a urti with shocks mit Stöße SF ₁	numero number Anzahl	SF ₂	
8	1.0	1.2	1.4	6	1.0	
16	1.2	1.4	1.6	240	1.25	
24	1.4	1.6	1.8	1200	1.35	

Fattori di servizio - Service factors - Betriebsfaktoren

Fattore di accelerazione delle masse - $k_{(a)}$	Mass acceleration factor - $k_{(a)}$	Beschleunigungsfaktor der Massen - $k_{(a)}$
Classi di carico	Load class	Belastungsklassen
A - Carico uniforme $k_{(a)} \leq 0.2$	A - Uniform load $k_{(a)} \leq 0.2$	A - Gleichförmige Last $k_{(a)} \leq 0.2$
B - Carico con urti moderati $0.2 < k_{(a)} \leq 3$	B - Moderate shock load $0.2 < k_{(a)} \leq 3$	B - Ungleichförmige Last $0.2 < k_{(a)} \leq 3$
C - Carico con forti urti $3 < k_{(a)} \leq 10$	C - Severe shock load $3 < k_{(a)} \leq 10$	C - Stark ungleichförmige Last $3 < k_{(a)} \leq 10$
A/h - Avviamenti / ora	A/h - Start-Stops / hour	A/h - Schaltungen / Stunde

$$k_{(a)} = \frac{\frac{J_2}{i i^2} + J_1}{J_m}$$

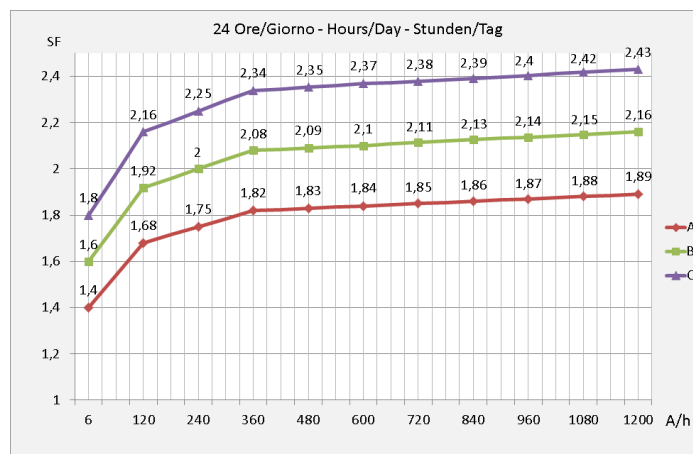
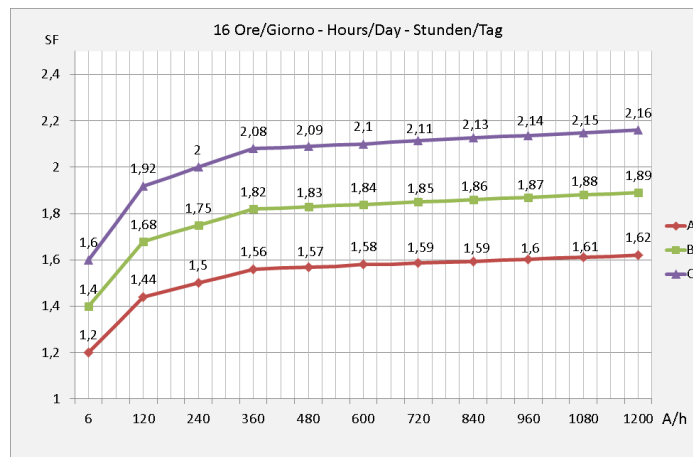
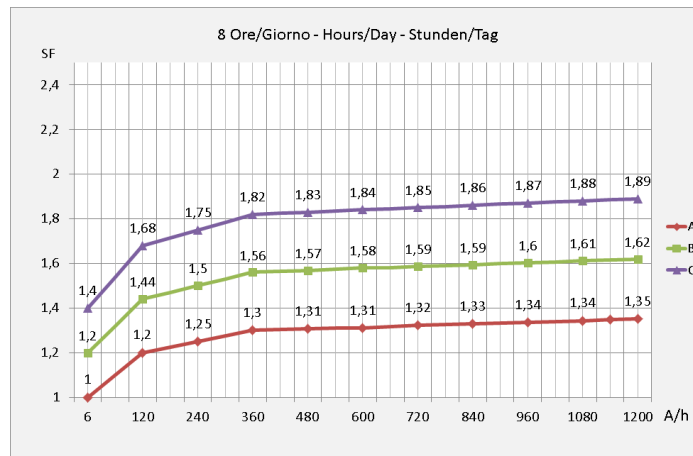

Fattori di servizio - Service factors - Betriebsfaktoren

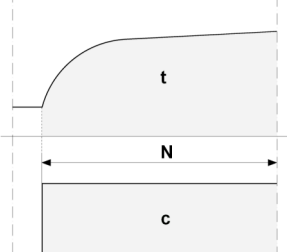
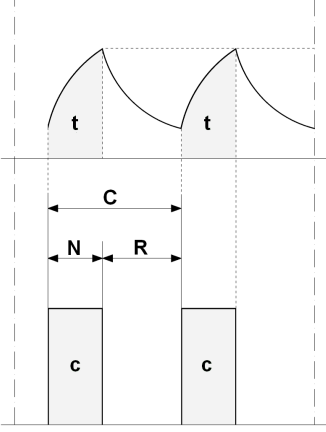
Tipo di servizio del motore	Duty type of the motor	Betriebsarten des Motors
<p>Le specifiche dei tipi di servizi sono definiti dalle norme CEI EN 60034-1 / IEC34-1.</p> <p>S1 Servizio continuo</p> <p>Funzionamento a carico costante (c) per un periodo di tempo indefinito (N), comunque sufficiente a raggiungere l'equilibrio termico.</p> <p>In servizio continuo, possono essere utilizzati i riduttori che nelle tabelle di selezione hanno un fattore di servizio SF1.0 o superiore.</p>	<p>Duty types are defined by CEI EN 60034-1 / IEC34-1 Standard.</p> <p>S1 Continuous duty</p> <p>Steady load (c) operation for an indefinite period (N), but long enough to achieve thermal balancing.</p> <p>On continuous duty, the gearboxes with selection table service factor SF1.0 or higher can be accordingly used.</p>	<p>Die Betriebsarten sind definiert in den Normen CEI EN 60034-1 / IEC34-1.</p> <p>S1 Dauerbetrieb</p> <p>Betrieb mit konstanter Belastung (c) über eine unbestimmte Zeit (N), ohne dass der thermische Beharrungszustand der Maschine beeinträchtigt wird.</p> <p>Im Dauerbetrieb können Getriebe eingesetzt werden, die in den Auswahltabellen einen Betriebsfaktor SF1.0 oder höher aufweisen.</p>
<p>N = Tempo di lavoro Operation time Betriebszeit</p> <p>c = Carico Load Belastung</p> <p>t = Tempo Time Zeit</p> 		
<p>S3 Servizio intermittente periodico</p> <p>Funzionamento secondo un ciclo (C) comprendente un periodo di tempo a carico costante (N) ed un periodo di tempo di riposo (R). Gli avviamenti non influiscono sulle temperature. Il ciclo (C) di riferimento è di 10 minuti complessivi.</p> <p>In servizio intermittente periodico, possono essere utilizzati i riduttori che nelle tabelle di selezione hanno un fattore di servizio SF pari al rapporto di intermittenza (k_{S3}) o superiore.</p> <p>Il rapporto di intermittenza viene determinato secondo la formula seguente.</p>	<p>S3 Periodic intermittent duty</p> <p>Operation according to cycle (C) including steady load time (N) and rest time (R).</p> <p>Starts/stops do not affect temperature. Reference cycle (C) is 10 minutes overall.</p> <p>On periodic intermittent duty, the gearboxes with selection table service factor matching the intermittence ratio service factor (k_{S3}) or higher can be accordingly used.</p> <p>Intermittence ratio is calculated according the following formula.</p>	<p>S3 Aussetzbetriebe</p> <p>Betrieb als Folge (C) gleichartiger Spiele mit konstanter Last während der Zeit (N) und einer folgenden Pause (R). Starten/Anhalten beeinflussen nicht die Temperatur. Für die Zyklusdauer (C) gilt eine Zeit von 10 Minuten.</p> <p>Im periodischen Intervallbetrieb können Getriebe verwendet werden, die in den Auswahltabellen einen Betriebsfaktor von SF haben, der gleich dem Intermittenzverhältnis (k_{S3}) ist. Die Intermittenzübersetzung wird nach die folgende Formel bestimmt.</p>
$\frac{N}{(N+R)} * 100 = \begin{matrix} 60\% & k_{S3} & \mathbf{0.9} \\ 40\% & k_{S3} & \mathbf{0.85} \\ 25\% & k_{S3} & \mathbf{0.75} \\ 15\% & k_{S3} & \mathbf{0.7} \end{matrix}$ <p>N = Tempo di lavoro Operation time Betriebszeit</p> <p>R = Tempo di riposo Rest time Pause</p> <p>C = Ciclo di lavoro Duty cycle Zyklusdauer</p> 		

Carichi esterni - External Loads - Ausgangsbelastungen

Carichi Radiali di uscita	Output Radial loads (OHL)	Ausgangsradialbelastungen										
<p>Il carico radiale riportato nelle tabelle, deve essere verificato in base alla velocità di uscita, alla posizione di montaggio (A) e al tipo di elemento di trasmissione (B) montato sull'albero di uscita del riduttore tramite i relativi fattori k_L e k_T; il carico radiale del riduttore F_{r2} deve essere uguale o maggiore al carico radiale dell'applicazione F_r.</p> <p style="text-align: center;">- A -</p> <p>Punto di applicazione del carico radiale Il carico radiale è considerato applicato alla mezzeria dell'albero di uscita. Altre posizioni originano carichi da correggere con l'appropriato fattore k_r. Esempi della distanza da spallamento dell'albero:</p>	<p>The radial (overhung) load shown in the tables, should be checked according to output speed, mounting position (A), type of the transmission element (B) fitted on the gearbox output shaft and rectified by the appropriate k_L and k_T rating factors; gearbox radial load F_{r2} must be equal or greater than application radial load F_r.</p> <p style="text-align: center;">- A -</p> <p>Application point of radial load OHL is considered as applied at the output shaft mid-point. Other positions origin loads to be adjusted by the appropriate factor k_L. Examples of the distance from the shaft shoulder:</p>	<p>Die Radialbelastung in den Tabellen müssen mit entsprechender Abtriebsdrehzahl, der Montageposition (A) und dem Übertragungselement (B) montiert auf der Getriebe-Ausgangswelle durch entsprechendem Faktoren k_L und k_T verglichen werden; die Radialbelastung des Getriebes F_{r2} muss gleich oder größer als die Radialbelastung der Anwendung F_r sein.</p> <p style="text-align: center;">- A -</p> <p>Anwendung Punkt der Radialbelastung Die Radialbelastung wird auf der Mitte der Ausgangswelle angelegt. Andere Positionen erzeugen Lasten, die mit dem entsprechenden Faktor k_L zu korrigieren sind. Beispiele für den Abstand der Stufenwelle:</p>										
<table border="1"> <thead> <tr> <th>k_L</th> <th>L</th> </tr> </thead> <tbody> <tr> <td>1.1</td> <td>1/4 * L</td> </tr> <tr> <td>1.0</td> <td>1/2 * L</td> </tr> <tr> <td>0.9</td> <td>3/4 * L</td> </tr> <tr> <td>0.8</td> <td>L</td> </tr> </tbody> </table>	k_L	L	1.1	1/4 * L	1.0	1/2 * L	0.9	3/4 * L	0.8	L		
k_L	L											
1.1	1/4 * L											
1.0	1/2 * L											
0.9	3/4 * L											
0.8	L											

- B - Elemento della trasmissione	- B - Transmission element	- B - Übertragungselement																												
<table border="1"> <thead> <tr> <th>k_T</th> <th>Tipo dell'elemento</th> <th>Element type</th> <th>Elementtyp</th> </tr> </thead> <tbody> <tr> <td>1,15</td> <td>Ingranaggio n. denti < 17</td> <td>Gear tooth No. < 17</td> <td>Zahnrad Zähnezahl < 17</td> </tr> <tr> <td>1,40</td> <td>Pignone catena n. denti < 13</td> <td>Chain sprocket tooth No. < 13</td> <td>Kettenrad Zähnezahl < 13</td> </tr> <tr> <td>1,25</td> <td>n. denti < 20</td> <td>tooth No. < 20</td> <td>Zähnezahl < 20</td> </tr> <tr> <td>1,00</td> <td>n. denti > 20</td> <td>tooth No. > 20</td> <td>Zähnezahl > 20</td> </tr> <tr> <td>2,50</td> <td>Puleggia per cinghie "V"</td> <td>Pulley for V-belt</td> <td>Riemen für Keilriemen "V"</td> </tr> <tr> <td>1,25</td> <td>cinghie dentate</td> <td>toothed-belt</td> <td>Zahnriemen</td> </tr> </tbody> </table>	k_T	Tipo dell'elemento	Element type	Elementtyp	1,15	Ingranaggio n. denti < 17	Gear tooth No. < 17	Zahnrad Zähnezahl < 17	1,40	Pignone catena n. denti < 13	Chain sprocket tooth No. < 13	Kettenrad Zähnezahl < 13	1,25	n. denti < 20	tooth No. < 20	Zähnezahl < 20	1,00	n. denti > 20	tooth No. > 20	Zähnezahl > 20	2,50	Puleggia per cinghie "V"	Pulley for V-belt	Riemen für Keilriemen "V"	1,25	cinghie dentate	toothed-belt	Zahnriemen		
k_T	Tipo dell'elemento	Element type	Elementtyp																											
1,15	Ingranaggio n. denti < 17	Gear tooth No. < 17	Zahnrad Zähnezahl < 17																											
1,40	Pignone catena n. denti < 13	Chain sprocket tooth No. < 13	Kettenrad Zähnezahl < 13																											
1,25	n. denti < 20	tooth No. < 20	Zähnezahl < 20																											
1,00	n. denti > 20	tooth No. > 20	Zähnezahl > 20																											
2,50	Puleggia per cinghie "V"	Pulley for V-belt	Riemen für Keilriemen "V"																											
1,25	cinghie dentate	toothed-belt	Zahnriemen																											

Carico radiale - Radial (overhung) load - Radialbelastung

$$F_{r2} = (2000 \times M_2) : D \times k_L \times k_T$$

$$F_{r2} \geq F_r$$

dove

F_r = Carico radiale dell'applicazione

F_{r2} = Carico radiale del riduttore

M_2 = Coppia di uscita del riduttore

where

F_r = Radial load of application

F_{r2} = Radial load of gearbox

M_2 = Output torque of gearbox

wo

F_r = Radial Belastung der Anwendung-

F_{r2} = Radial Belastung des Getriebes

M_2 = Ausgangsdrehmoment des Getriebes

Carichi Assiali di uscita	Output Axial loads	Ausgangsaxialbelastung
<p>Il valore del carico assiale $F_{a2} = F_{r2} \times 0.2$ è incluso nel valore dei carichi radiali di catalogo ed è valido sia a trazione che a compressione.</p>	<p>Axial load value $F_{a2} = F_{r2} \times 0.2$ is included within the catalogue radial load figure and is valid on both tensile and compressive stress.</p>	<p>Der Wert der Axialbelastung $F_{a2} = F_{r2} \times 0.2$ ist in dem Wert der Radialbelastung des Kataloges enthalten und gilt sowohl in Zug und Druck.</p>



Versioni - Versions - Ausführungen

MRD

- Motorriduttori a due e tre coppie di ingranaggi
Potenza: 0.06 kW a 22 kW a 4 poli
Giri uscita: 600 rpm a 3.3 rpm
- Geared motors with two and three gear sets
Powers: 0.06 kW to 22 kW, 4 poles
Output speed: 600 rpm to 3.3 rpm
- Zwei- u. Dreistufig Getriebemotoren
Leistung: 0.06 kW bis 22 kW, 4-polen
Ausgangsgeschwindigkeit: 600 UpM bis 3.3 UpM

FRD

- Riduttori a due e tre coppie di ingranaggi con flangia motore entrata, albero d'entrata cavo e giunto elastico
Flange motore: IEC 56 a IEC 180 e NEMA 56C a NEMA 210TC
Coppia: 27 Nm [240 in-lb] a 2100 Nm [18590 in-lb]
Rapporti di riduzione: 2.25:1 a 630:1
- Gearboxes with two and three gear sets and with input motor flange, input quill and flexible coupling
Motor flanges: IEC 56 to IEC 180 and NEMA 56C to NEMA 210TC
Output torque: 27 Nm [240 in-lb] to 2100 Nm [18590 in-lb]
Reduction ratios: 2.25:1 to 630:1
- Zwei- u. Dreistufig Getriebemotoren mit Motorflansch, Eingangshohlwelle und Kupplung
Motorflansche: IEC 56 bis IEC 180 u. NEMA 56C bis NEMA 210TC
Ausgangsdrehmoment: 27 Nm [240 in-lb] bis 2100 Nm [18590 in-lb]
Untersetzungsverhältnis: 2.25:1 bis 630:1

SRD

- Riduttori a due e tre coppie di ingranaggi senza flangia motore di entrata, ma con albero entrata cavo e giunto elastico
Coppia: 27 Nm [240 in-lb] a 2100 Nm [18590 in-lb]
Rapporti di riduzione: 2.25:1 a 630:1
- Gearboxes with two and three gear sets without input motor flange, but with input hollow shaft and flexible coupling
Output torque: 27 Nm [240 in-lb] to 2100 Nm [18590 in-lb]
Reduction ratios: 2.25:1 to 630:1
- Zwei- u. Dreistufig Getriebemotoren ohne Motorflansch, aber mit Hohl-eingangswelle und Kupplung
Ausgangsdrehmoment: 27 Nm [240 in-lb] bis 2100 Nm [18590 in-lb]
Untersetzungsverhältnis: 2.25:1 bis 630:1

RD

- Riduttori a due e tre coppie di ingranaggi con albero entrata sporgente
Coppia: 27 Nm [240 in-lb] a 2100 Nm [18590 in-lb]
Rapporti di riduzione: 2.25:1 a 630:1
- Gearboxes with two and three gear sets and input solid shaft
Output torque: 27 Nm [240 in-lb] to 2100 Nm [18590 in-lb]
Reduction ratios: 2.25:1 to 630:1
- Zwei- u. Dreistufig Getriebemotoren mit Eingangswelle
Ausgangsdrehmoment: 27 Nm [240 in-lb] bis 2100 Nm [18590 in-lb]
Untersetzungsverhältnis: 2.25:1 bis 630:1

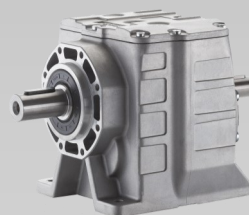
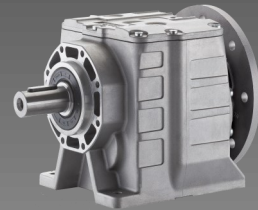
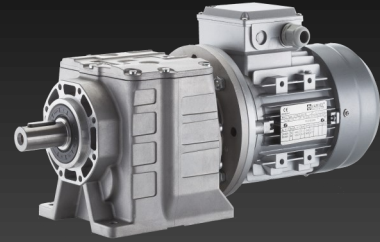

Potenza termica - Thermal power - Thermische Nennleistung

	i _n	FRD 02-03		FRD 12 - 13		FRD 22 - 23		FRD 32 - 33		FRD 42 - 43		FRD 52 - 53		FRD 62 - 63	
		P ₁ [kW]	Pt ₁ [kW]	P ₁ [kW]	Pt ₁ [kW]	P ₁ [kW]	Pt ₁ [kW]	P ₁ [kW]	Pt ₁ [kW]	P ₁ [kW]	Pt ₁ [kW]	P ₁ [kW]	Pt ₁ [kW]	P ₁ [kW]	Pt ₁ [kW]
2c	2.25	1.80	0.24	2.70	1.83	5.30	2.33	11.20	6.76	18.80	7.85	39.10	7.22	78.20	13.75
	2.50	1.82	0.26	2.50	1.86	4.99	2.46	10.49	7.17	18.80	7.52	34.00	7.49	78.20	14.07
	2.80	1.60	0.26	2.40	1.73	4.60	2.28	9.80	6.34	16.30	7.29	33.50	7.25	67.00	14.40
	3.15	1.57	0.27	2.21	1.75	4.37	2.40	9.18	6.68	16.30	6.99	33.50	7.45	67.10	14.55
	3.55	1.30	0.26	2.00	1.56	4.00	2.20	8.40	5.76	13.80	6.51	29.30	6.96	58.70	13.92
	4.0	1.32	0.27	1.84	1.58	3.75	2.30	7.87	6.04	13.80	6.28	29.30	7.11	58.70	13.95
	4.5	1.10	0.24	1.60	1.40	3.30	2.01	7.00	5.07	11.90	5.85	25.10	6.50	50.30	13.20
	5.0	1.13	0.25	1.55	1.41	3.12	2.10	6.55	5.24	11.90	5.65	25.10	6.64	50.30	13.10
	5.6	1.40	0.22	1.40	1.22	2.80	1.91	---	---	10.00	5.03	20.30	5.71	40.60	11.74
	6.3	1.22	0.26	2.06	1.39	4.13	1.81	9.31	5.38	13.80	5.04	25.60	5.96	43.60	11.36
	7.1	1.10	0.22	1.20	1.07	2.20	1.55	4.60	3.79	6.90	4.16	13.60	4.85	27.30	9.79
	8.0	0.97	0.25	1.71	1.33	3.39	1.82	7.63	5.00	11.20	4.78	20.40	5.67	34.80	11.15
	9.0	0.89	0.22	0.76	0.82	1.40	1.45	---	---	4.90	3.76	8.70	4.54	20.80	9.40
	10.0	0.78	0.25	1.33	1.23	2.74	1.76	6.17	4.62	8.90	4.43	17.00	5.37	29.00	10.39
	11.2	0.73	0.24	0.49	1.16	0.80	1.69	---	---	3.10	4.29	5.70	5.23	11.50	10.10
	12.5	0.62	0.23	1.06	1.09	2.17	1.64	4.87	4.12	7.30	4.29	14.00	5.10	23.80	9.72
	16.0	0.49	0.21	0.88	0.96	1.78	1.54	3.72	3.55	6.00	3.74	11.20	4.58	19.00	8.86
	20.0	0.38	0.18	0.71	0.86	1.42	1.32	3.19	3.22	4.70	3.22	8.60	3.98	14.70	7.70
	25.0	0.31	0.15	0.56	0.71	1.11	1.22	2.48	2.87	3.80	2.95	6.80	3.70	12.40	7.43
	31.5	0.27	0.13	0.46	0.63	0.95	1.08	1.68	2.38	3.20	2.62	5.70	3.28	9.40	6.10
35.5	0.16	0.15	---	---	---	---	---	---	---	---	---	---	---	---	---
40	0.13	0.12	0.27	0.60	0.53	1.00	1.10	2.36	1.50	2.10	2.90	3.01	5.40	5.87	
50	0.11	0.11	0.22	0.54	0.41	0.85	0.85	2.01	1.20	1.87	2.20	2.60	4.50	5.21	
63	---	---	0.17	0.45	0.34	0.75	0.69	1.76	1.00	1.39	1.90	2.26	4.00	4.77	
3c	40	0.22	0.32	0.38	0.71	0.75	1.21	1.68	1.88	2.40	2.39	4.70	1.86	8.10	4.92
	50	0.18	0.31	0.29	0.67	0.59	1.16	1.33	1.76	2.00	2.28	3.90	1.78	6.70	4.58
	63	0.14	0.30	0.23	0.64	0.48	1.11	1.01	1.61	1.60	2.13	3.20	1.66	5.30	4.16
	80	0.11	0.29	0.19	0.60	0.39	1.00	0.87	1.51	1.20	1.94	2.50	1.49	4.10	3.67
	90	---	---	---	---	---	---	---	---	---	---	---	---	3.50	3.53
	100	0.09	0.27	0.16	0.55	0.30	0.94	0.67	1.38	1.00	1.84	2.00	1.39	3.30	3.39
	112	---	---	---	---	---	---	---	---	---	---	1.70	1.28	---	---
	125	0.07	0.26	0.12	0.48	0.25	0.86	0.51	1.23	0.80	1.69	2.50	1.17	2.70	3.05
	140	---	---	---	---	---	---	---	---	---	---	1.30	1.08	---	---
	160	0.05	0.23	0.10	0.41	0.19	0.68	0.40	1.06	0.70	3.72	1.20	1.24	2.20	2.66
	180	0.05	0.22	---	---	---	---	---	---	---	---	---	---	2.00	3.03
	200	0.03	0.22	0.08	0.39	0.15	0.63	0.34	1.01	0.50	3.25	1.00	1.16	1.70	2.92
	225	---	---	---	---	---	---	---	---	---	---	0.80	1.09	1.50	2.75
	250	0.02	0.20	0.06	0.35	0.12	0.61	0.26	1.37	0.40	2.99	0.70	1.00	1.30	2.55
	280	0.02	0.19	---	---	---	---	---	---	---	---	0.70	0.95	---	---
	315	0.02	0.18	0.05	0.33	0.10	0.58	0.22	0.91	0.30	2.64	0.40	0.88	1.00	2.26
	355	---	---	---	---	---	---	---	---	---	---	---	---	0.9	2.17
	400	---	---	0.03	0.31	0.06	0.55	0.11	1.21	0.17	2.20	0.30	0.80	---	---
	450	---	---	---	---	---	---	---	---	---	---	---	---	0.60	2.08
	500	---	---	0.02	0.30	0.04	0.50	0.09	0.80	0.14	1.73	0.30	0.72	---	---
560	---	---	---	---	---	---	---	---	---	---	0.23	0.69	0.50	1.98	
630	---	---	0.02	0.27	0.04	0.48	0.07	1.21	0.11	1.12	0.20	0.66	---	---	

2c, 3c - Numero delle coppie di riduzione

2c, 3c - Number of reduction stages

2c, 3c - Anzahl der Getriebestufen



Selezione Riduttore - Speed Reducer Selection - Getriebeauswahl

RD0 - 50 Nm - 1400 rpm

	i_n	i_r	n_2 [rpm]	M_2 [Nm]	P_1 [kW]	F_{r1} [N]	F_{r2} [N]	$J_1 (x 10^{-4})$ [kgm ²]	56	63	71	80
FRD02 2 c	2.25	2.314	605	27	1.8	*	400	0.6467	⊙	⊙	⊙	(⊙)
	2.5	2.568	545	30	1.82	*	430	0.5251	⊙	⊙	⊙	(⊙)
	2.80	2.952	474	30	1.60	*	410	0.4835	⊙	⊙	⊙	(⊙)
	3.15	3.277	427	33	1.57	*	420	0.4443	⊙	⊙	⊙	(⊙)
	3.55	3.834	365	34	1.3	*	420	0.4253	⊙	⊙	⊙	(⊙)
	4.0	4.256	329	36	1.32	*	430	0.3884	⊙	⊙	⊙	(⊙)
	4.5	4.753	295	34	1.10	*	470	0.3674	⊙	⊙	⊙	(⊙)
	5.0	5.276	265	38	1.13	*	520	0.3587	⊙	⊙	⊙	(⊙)
	5.6	5.747	244	52	1.40	*	580	0.3841	⊙	⊙	⊙	(⊙)
	6.3	6.253	234	48	1.22	36	640	0.4296	⊙	⊙	⊙	(⊙)
	7.1	7.333	191	53	1.10	50	680	0.4015	⊙	⊙	⊙	(⊙)
	8.0	7.979	175	49	0.97	110	720	0.3856	⊙	⊙	⊙	(⊙)
	9.0	9.524	147	54	0.89	140	770	0.3618	⊙	⊙	⊙	(⊙)
	10.0	10.362	135	50	0.78	172	820	0.3536	⊙	⊙	⊙	(⊙)
	11.2	11.806	119	54	0.73	190	850	0.3415	⊙	⊙	⊙	(⊙)
	12.5	12.844	109	50	0.62	211	920	0.3361	⊙	⊙	⊙	(⊙)
	16.0	16.320	86	51	0.49	244	1020	0.3218	⊙	⊙	⊙	(⊙)
	20.0	21.533	65	51	0.38	273	1170	0.3106	⊙	⊙	⊙	
	25.0	26.747	52	52	0.31	292	1200	0.3045	⊙	⊙	⊙	
	31.5	30.222	46	52	0.27	299	1200	0.3019	⊙	⊙	⊙	
35.5	34.675	40	35	0.16	638	1430	0.3089	⊙	⊙			
40	43.070	33	35	0.13	646	1430	0.3033	⊙	⊙			
50	48.667	29	36	0.11	651	1420	0.3010	⊙	⊙			
FRD03 3c	40	36.892	37	52	0.22	76	1200	0.3065	⊙	⊙	⊙	
	50	47.074	30	52	0.18	149	1200	0.6431	⊙	⊙		
	63	61.135	23	52	0.14	208	1200	0.6342	⊙	⊙		
	80	75.782	18	52	0.11	248	1200	0.6299	⊙	⊙		
	100	96.288	15	52	0.09	281	1200	0.6270	⊙			
	125	127.047	11	52	0.07	312	1200	0.6252	⊙			
	160	157.805	8.9	52	0.05	332	1200	0.6244	⊙			
	180	178.311	7.9	52	0.05	341	1200	0.6241	⊙			
	200	204.583	6.9	36	0.03	367	1420	0.6251	⊙			
	250	254.113	5.5	36	0.02	376	1420	0.6244	⊙			
	280	287.133	4.9	36	0.02	380	1420	0.6241	⊙			
	315	324.444	4.3	36	0.02	380	1420	0.6462	⊙			

2c, 3c - Numero coppie di riduzione
 * - Azionamento con giunto entrata
 ⊙ - B5 e B14
 (⊙) - Solo B14

- Number of reduction stages
 - Drive via flexible coupling
 - B5 and B14
 - B14 only

- Anzahl der Getriebestufen
 - Antrieb mit Kupplung
 - B5 u. B14
 - Nur B14

Lubrificazione (litri olio) e Pesì (kg) - Lubrication (Oil litres) and Weights (kg) - Schmierung (Öl Liter) u. Gewichte (kg)

	H	V	kg
FRD02	0.2	0.3	3.0
FRD03	0.3	0.4	3.2

Selezione Riduttore - Speed Reducer Selection - Getriebeauswahl
RD
RD1 - 100 Nm - 1400 rpm

	i_n	i_r	n_2 [rpm]	M_2 [Nm]	P_1 [kW]	F_{r1} [N]	F_{r2} [N]	$J_1 (x 10^{-4})$ [kgm ²]	56	63	71	80	90	
FRD 12 2c	2.25	2.348	596	40	2.70	*	1200	1.2989	(⊙)	⊙	⊙	⊙	⊙	
	2.5	2.534	560	40	2.50	*	1300	1.1152	(⊙)	⊙	⊙	⊙	⊙	
	2.80	2.855	490	43	2.40	*	1350	0.1056	(⊙)	⊙	⊙	⊙	⊙	
	3.15	3.081	445	43	2.21	*	1400	0.9332	(⊙)	⊙	⊙	⊙	⊙	
	3.55	3.716	377	46	2.00	*	1450	0.8131	(⊙)	⊙	⊙	⊙	⊙	
	4.0	4.011	350	47	1.84	*	1500	0.7691	(⊙)	⊙	⊙	⊙	⊙	
	4.5	4.700	298	49	1.60	*	1550	0.7912	(⊙)	⊙	⊙	⊙	⊙	
	5.0	5.073	280	50	1.55	*	1600	0.6732	(⊙)	⊙	⊙	⊙	⊙	
	5.6	5.726	251	51	1.40	*	1650	0.7514	(⊙)	⊙	⊙	⊙	⊙	
	6.3	6.686	220	87	2.06	*	1700	0.8357	(⊙)	⊙	⊙	⊙	⊙	
	7.1	7.161	196	54	1.20	*	1750	0.7857	(⊙)	⊙	⊙	⊙	⊙	
	8.0	8.129	175	88	1.71	*	1800	0.7441	(⊙)	⊙	⊙	⊙	⊙	
	9.0	9.315	150	45	0.76	*	1850	0.7013	(⊙)	⊙	⊙	⊙		
	10.0	10.581	140	89	1.33	*	1900	0.6575	(⊙)	⊙	⊙	⊙	⊙	
	11.2	11.468	122	35	0.49	*	1900	0.6317	(⊙)	⊙	⊙	⊙		
	12.5	13.384	110	90	1.06	*	1900	0.6035	(⊙)	⊙	⊙	⊙	⊙	
	16.0	16.309	90	90	0.88		20	1900	0.5710	(⊙)	⊙	⊙	⊙	⊙
	20.0	20.391	70	92	0.71		55	1900	0.5435	(⊙)	⊙	⊙	⊙	
	25.0	26.522	55	93	0.56		75	2000	0.5211	(⊙)	⊙	⊙	⊙	
	31.5	32.653	45	94	0.46		100	2000	0.5088	(⊙)	⊙	⊙	⊙	
40	39.083	35	66	0.27		590	2000	0.5184	(⊙)	⊙	⊙			
50	48.118	30	67	0.22		630	2000	0.5070	(⊙)	⊙	⊙			
63	61.670	22	68	0.17		640	2000	0.4975	(⊙)	⊙				
FRD 13 3c	40	40.103	35	95	0.38		120	1500	0.5267	(⊙)	⊙	⊙		
	50	52.201	30	96	0.29		210	1600	1.5521	(⊙)	⊙	⊙		
	63	66.028	22	97	0.23		270	1700	1.5394	(⊙)	⊙	⊙		
	80	80.432	18	99	0.19		320	1800	1.5333	(⊙)	⊙	⊙		
	100	100.596	14	100	0.16		350	1900	1.5288	(⊙)	⊙			
	125	130.843	11	100	0.12		400	2000	1.5260	(⊙)	⊙			
	160	165.075	9.0	100	0.10		410	2000	1.9460	(⊙)	⊙			
	200	206.460	7.0	100	0.08		420	2000	1.9423	(⊙)				
	250	268.538	5.5	100	0.06		430	2000	1.9401	(⊙)				
	315	330.615	4.5	100	0.05		450	2000	1.9391	(⊙)				
	400	395.719	3.5	71	0.03		480	2200	1.9401	(⊙)				
	500	487.197	2.8	71	0.02		490	2200	1.9391	(⊙)				
	630	624.413	2.2	71	0.02		510	2200	1.9385	(⊙)				

2c, 3c - Numero coppie di riduzione
 * - Azionamento con giunto entrata
 ⊙ - B5 e B14
 (⊙) - Solo B5

- Number of reduction stages
 - Drive via flexible coupling
 - B5 and B14
 - B5 only

- Anzahl der Getriebestufen
 - Antrieb mit Kupplung
 - B5 u. B14
 - Nur B5

Lubrificazione (litri olio) e Pesì (kg) - Lubrication (Oil litres) and Weights (kg) - Schmierung (Öl Liter) u. Gewichte (kg)

	H	V	kg
FRD12	0.5	0.7	4.8
FRD13	0.5	0.7	4.8



Selezione Riduttore - Speed Reducer Selection - Getriebeauswahl

RD2 - 200 Nm - 1400 rpm

	i_n	i_r	n_2 [rpm]	M_2 [Nm]	P_1 [kW]	F_{r1} [N]	F_{r2} [N]	$J_1 (x 10^{-4})$ [kgm ²]	63	71	80	90	100	112
FRD 22 2c	2.25	2.313	599	79	5.30	*	1000	4.1128		⊙	⊙	⊙	⊙	⊙
	2.5	2.548	560	80	4.99	*	1100	3.4569		⊙	⊙	⊙	⊙	⊙
	2.80	2.846	487	85	4.60	*	1200	3.1032		⊙	⊙	⊙	⊙	⊙
	3.15	3.133	445	87	4.37	*	1350	2.8995		⊙	⊙	⊙	⊙	⊙
	3.55	3.558	390	91	4.00	*	1400	2.6305		⊙	⊙	⊙	⊙	⊙
	4.0	3.917	350	93	3.75	*	1500	2.4858		⊙	⊙	⊙	⊙	⊙
	4.5	4.554	304	97	3.30	*	1600	2.2505		⊙	⊙	⊙	⊙	⊙
	5.0	5.013	280	99	3.12	*	1700	2.1816		⊙	⊙	⊙	⊙	⊙
	5.6	5.609	247	102	2.80	*	1760	2.5308		⊙	⊙	⊙	⊙	
	6.3	6.717	220	175	4.13	*	1850	2.7248		⊙	⊙	⊙	⊙	⊙
	7.1	7.115	195	99	2.20	*	1910	2.6423		⊙	⊙	⊙	⊙	
	8.0	8.267	175	177	3.39	*	2000	2.4162		⊙	⊙	⊙	⊙	⊙
	9.0	9.203	151	83	1.40	*	2040	2.2654		⊙	⊙	⊙		
	10.0	10.333	140	179	2.74	*	2100	2.1765		⊙	⊙	⊙	⊙	
	11.2	11.859	118	60	0.8	*	2150	2.0568		⊙	⊙	⊙		
	12.5	13.227	110	181	2.17	*	2200	1.9928		⊙	⊙	⊙	⊙	
	16.0	16.290	90	183	1.78	*	2300	1.8826		⊙	⊙	⊙	⊙	
	20.0	20.667	70	186	1.42	*	2400	1.7924		⊙	⊙	⊙		
	25.0	26.729	55	188	1.11	40	2500	1.7234		⊙	⊙	⊙		
	31.5	31.477	45	190	0.95	50	2600	1.6937		⊙	⊙	⊙		
40	39.388	35	131	0.53	720	2900	1.6604		⊙	⊙				
50	50.758	30	133	0.41	740	3050	1.6757		⊙	⊙				
63	62.127	22	134	0.34	760	3200	1.6537		⊙					
FRD 23 3c	40	40.759	192	192	0.75	140	2300	1.7501	(⊙)	⊙	⊙			
	50	52.172	30	194	0.59	280	2400	2.5709	(⊙)	⊙	⊙			
	63	64.256	22	196	0.48	380	2500	2.5490	(⊙)	⊙	⊙			
	80	81.519	18	199	0.39	460	2600	2.5337	(⊙)	⊙				
	100	105.431	14	200	0.30	550	2700	2.5230	(⊙)	⊙				
	125	124.159	11	200	0.25	590	2800	2.5195	(⊙)	⊙				
	160	164.938	9.0	200	0.19	430	2900	3.0999	(⊙)	⊙				
	200	209.250	7.0	200	0.15	520	3000	3.0889	(⊙)					
	250	270.630	5.5	200	0.12	580	3200	3.0816	(⊙)					
	315	318.704	4.5	200	0.10	600	3500	3.0796	(⊙)					
	400	398.802	3.5	140	0.06	700	3500	3.0809	(⊙)					
	500	513.920	2.8	140	0.04	730	3500	3.0790	(⊙)					
	630	629.039	2.2	140	0.04	760	3500	3.0783	(⊙)					

- | | | |
|-------------------------------------|-------------------------------|-----------------------------|
| 2c, 3c - Numero coppie di riduzione | - Number of reduction stages | - Anzahl der Getriebestufen |
| * - Azionamento con giunto entrata | - Drive via flexible coupling | - Antrieb mit Kupplung |
| ⊙ - B5 e B14 | - B5 and B14 | - B5 u. B14 |
| (⊙) - Solo B5 | - B5 only | - Nur B5 |

Lubrificazione (litri olio) e Pesi (kg) - Lubrication (Oil litres) and Weights (kg) - Schmierung (Öl Liter) u. Gewichte (kg)

	H	V	kg
FRD22	0.8	1.0	7.9
FRD23	0.8	1.0	8.5

Selezione Riduttore - Speed Reducer Selection - Getriebeauswahl
RD
RD3 - 420 Nm - 1400 rpm

	i_n	i_r	n_2 [rpm]	M_2 [Nm]	P_1 [kW]	F_{r1} [N]	F_{r2} [N]	$J_1 (x 10^{-4})$ [kgm ²]	63	71	80	90	100	112
FRD 32 2c	2.25	2.420	579	171	11.20	800	2000	9.3605		⊙	⊙	⊙	⊙	⊙
	2.5	2.697	560	179	10.49	830	2100	7.5606		⊙	⊙	⊙	⊙	⊙
	2.80	2.983	469	184	9.80	840	2100	6.5382		⊙	⊙	⊙	⊙	⊙
	3.15	3.324	445	193	9.18	850	2200	5.9052		⊙	⊙	⊙	⊙	⊙
	3.55	3.733	375	198	8.40	860	2200	5.4374		⊙	⊙	⊙	⊙	⊙
	4.0	4.160	350	207	7.87	880	2300	4.6789		⊙	⊙	⊙	⊙	⊙
	4.5	4.783	293	211	7.00	890	2400	4.2591		⊙	⊙	⊙	⊙	⊙
	5.0	5.331	280	221	6.55	900	2500	3.7739		⊙	⊙	⊙	⊙	⊙
	6.3	6.261	220	369	9.31	920	2700	5.2968		⊙	⊙	⊙	⊙	⊙
	7.1	7.484	187	217	4.6	960	2900	4.6784		⊙	⊙	⊙	⊙	⊙
	8.0	7.717	175	373	7.63	980	3100	4.4149		⊙	⊙	⊙	⊙	⊙
	10.0	9.658	140	377	6.17	1030	3600	3.7274		⊙	⊙	⊙	⊙	⊙
	12.5	12.375	110	382	4.87	1070	3800	3.1944		⊙	⊙	⊙	⊙	⊙
	16.0	16.451	90	387	3.72	1110	4000	3.2491		⊙	⊙	⊙	⊙	⊙
	20.0	19.362	70	390	3.19	1110	4200	2.9048		⊙	⊙	⊙	⊙	⊙
	25.0	25.255	55	395	2.48	1150	4500	2.3847		⊙	⊙	⊙	⊙	
	31.5	33.214	45	353	1.68	1210	4700	2.2448		⊙	⊙	⊙	⊙	
	40	38.571	35	268	1.10	1380	4900	2.3551		⊙	⊙	⊙		
	50	50.727	30	272	0.85	1390	5000	2.2276		⊙	⊙	⊙		
	63	63.333	22	275	0.69	1400	5000	2.1571		⊙	⊙			
FRD 33 3c	40	38.063	35	405	1.68	100	4000	2.3849		⊙	⊙	⊙	⊙	
	50	48.772	30	410	1.33	350	4100	4.8227		⊙	⊙	⊙		
	63	64.836	22	414	1.01	580	4200	5.2165		⊙	⊙	⊙		
	80	76.310	18	419	0.87	690	4400	5.0177		⊙	⊙	⊙		
	100	99.535	14	420	0.67	830	4500	4.6787		⊙	⊙			
	125	130.903	11	420	0.51	870	4600	4.6625		⊙	⊙			
	160	167.799	9.0	420	0.40	850	4700	6.8317		⊙				
	200	197.495	7.0	420	0.34	900	4100	6.6412		⊙				
	250	257.602	5.5	420	0.26	930	4300	6.3012		⊙				
	315	307.214	4.5	420	0.22	950	4500	6.3065		⊙				
	400	393.429	3.5	280	0.11	1150	5000	6.3129		⊙				
	500	517.418	2.8	280	0.09	1170	5000	6.3038		⊙				
	630	646.000	2.2	280	0.07	1200	5000	6.2999		⊙				

 2c, 3c - Numero coppie di riduzione
 ⊙ - B5 e B14

 - Number of reduction stages
 - B5 and B14

 - Anzahl der Getriebestufen
 - B5 u. B14

Lubrificazione (litri olio) e Pesi (kg) - Lubrication (Oil litres) and Weights (kg) - Schmierung (Öl Liter) u. Gewichte (kg)

	H	V	kg
FRD32	1.3	1.8	13.5
FRD33	1.6	2.1	14.5



Selezione Riduttore - Speed Reducer Selection - Getriebeauswahl

RD4 - 650 Nm - 1400 rpm

	i_n	i_r	n_2 [rpm]	M_2 [Nm]	P_1 [kW]	F_{r1} [N]	F_{r2} [N]	$J_1 (x 10^{-4})$ [kgm ²]	71	80	90	100	112	132
FRD 42 2c	2.25	2.343	598	278	18.8	480	2000	22.729		⊙	⊙	⊙	⊙	⊙
	2.5	2.489	560	295	18.8	490	2300	18.663		⊙	⊙	⊙	⊙	⊙
	2.80	2.929	478	301	16.3	500	2400	16.454		⊙	⊙	⊙	⊙	⊙
	3.15	3.111	445	320	16.3	530	2500	14.976		⊙	⊙	⊙	⊙	⊙
	3.55	3.727	376	324	13.8	550	2600	13.145		⊙	⊙	⊙	⊙	⊙
	4.0	3.960	350	354	13.8	560	2700	12.317		⊙	⊙	⊙	⊙	⊙
	4.5	4.547	308	342	11.9	570	2800	12.115		⊙	⊙	⊙	⊙	⊙
	5.0	4.830	280	363	11.9	580	3000	10.808		⊙	⊙	⊙	⊙	⊙
	5.6	5.674	247	359	10.0	750	3000	12.483		⊙	⊙	⊙	⊙	⊙
	6.3	6.286	220	548	13.8	1000	3100	13.636		⊙	⊙	⊙	⊙	⊙
	7.1	7.321	191	320	6.9	1040	3300	12.434		⊙	⊙	⊙	⊙	⊙
	8.0	7.857	175	554	11.2	1070	3500	11.759		⊙	⊙	⊙	⊙	⊙
	9.0	9.124	153	282	4.9	1100	3600	10.943		⊙	⊙	⊙	⊙	⊙
	10.0	10.000	140	561	8.9	1140	3700	10.331		⊙	⊙	⊙	⊙	⊙
	11.2	11.049	127	213	3.1	1160	4000	9.9372		⊙	⊙	⊙	⊙	
	12.5	12.199	110	566	7.3	1180	4600	9.4739		⊙	⊙	⊙	⊙	⊙
	16.0	15.223	90	573	6.0	1210	5700	8.7672		⊙	⊙	⊙	⊙	⊙
	20.0	19.643	70	580	4.7	1250	5800	8.1877		⊙	⊙	⊙	⊙	⊙
	25.0	24.478	55	586	3.8	1270	6000	7.8266		⊙	⊙	⊙	⊙	
	31.5	29.643	45	582	3.2	1280	6100	7.6050		⊙	⊙	⊙	⊙	
	40	41.538	35	382	1.5	1580	7000	7.7554		⊙	⊙			
50	50.303	30	385	1.2	1590	7500	7.5565		⊙	⊙				
63	62.963	22	390	1.0	1590	8000	7.3860		⊙	⊙				
FRD 43 3c	40	41.875	35	610	2.4	400	5000	7.5184	(⊙)	⊙	⊙	⊙		
	50	51.084	30	620	2.1	640	5100	9.8959	(⊙)	⊙	⊙	⊙		
	63	63.747	22	620	1.6	860	5200	10.279	(⊙)	⊙	⊙			
	80	82.254	18	630	1.2	1070	5200	10.062	(⊙)	⊙	⊙			
	100	102.502	14	650	1.0	1210	5300	9.7166	(⊙)	⊙	⊙			
	125	124.129	11	650	0.8	1310	5400	9.6972	(⊙)	⊙	⊙			
	160	160.689	9.0	650	0.7	1250	5500	11.857	(⊙)	⊙				
	200	207.341	7.0	650	0.5	1160	5600	11.663	(⊙)	⊙				
	250	258.379	5.5	650	0.4	1290	5800	11.324	(⊙)					
	315	312.297	4.5	650	0.3	1390	6000	11.326	(⊙)					
	400	438.462	3.5	450	0.17	1610	7000	11.333	(⊙)					
	500	530.976	2.8	450	0.14	1650	7500	11.324	(⊙)					
	630	664.609	2.2	450	0.11	1670	8000	11.319	(⊙)					

2c, 3c - Numero coppie di riduzione
 ⊙ - B5 e B14
 (⊙) - Solo B5

- Number of reduction stages
 - B5 and B14
 - B5 only

- Anzahl der Getriebestufen
 - B5 u. B14
 - Nur B5

Lubrificazione (litri olio) e Pesi (kg) - Lubrication (Oil litres) and Weights (kg) - Schmierung (Öl Liter) u. Gewichte (kg)

	H	V	kg
FRD42	2.2	3.0	20.0
FRD43	2.2	3.4	21.5

Selezione Riduttore - Speed Reducer Selection - Getriebeauswahl
RD
RD5 - 1200 Nm - 1400 rpm

	i_n	i_r	n_2 [rpm]	M_2 [Nm]	P_1 [kW]	F_{r1} [N]	F_{r2} [N]	$J_1 (x 10^{-4})$ [kgm ²]	80	90	100	112	132	160
FRD 52 2c	2.25	2.323	603	632	39.1	720	3200	31.657		⊙	⊙	⊙	(⊙)	⊙
	2.5	2.5567	548	630	34.0	750	3400	26.128		⊙	⊙	⊙	(⊙)	⊙
	2.80	2.945	475	624	33.5	770	3500	24.154		⊙	⊙	⊙	(⊙)	⊙
	3.15	3.241	432	687	33.5	790	3700	20.966		⊙	⊙	⊙	(⊙)	⊙
	3.55	3.568	392	662	29.3	820	3900	18.578		⊙	⊙	⊙	(⊙)	⊙
	4.0	3.926	357	728	29.3	850	4000	17.244		⊙	⊙	⊙	(⊙)	⊙
	4.5	4.398	318	698	25.1	860	4300	16.421		⊙	⊙	⊙	(⊙)	⊙
	5.0	4.840	289	769	25.1	870	4500	15.131		⊙	⊙	⊙	(⊙)	⊙
	5.6	5.561	252	713	20.3	1100	4500	17.750		⊙	⊙	⊙	(⊙)	⊙
	6.3	6.454	217	1045	25.6	1500	4600	23.290		⊙	⊙	⊙	(⊙)	⊙
	7.1	7.305	192	630	13.6	1550	4800	18.351		⊙	⊙	⊙	(⊙)	⊙
	8.0	8.185	171	1058	20.4	1600	5200	16.463		⊙	⊙	⊙	(⊙)	⊙
	9.0	9.353	150	512	8.7	1650	5300	15.154		⊙	⊙	⊙	(⊙)	⊙
	10.0	9.915	141	1068	17.0	1700	5500	14.463		⊙	⊙	⊙	(⊙)	⊙
	11.2	11.31	124	405	5.7	1750	6000	13.831		⊙	⊙	⊙	(⊙)	⊙
	12.5	12.222	115	1079	14.0	1780	6900	13.264		⊙	⊙	⊙	(⊙)	⊙
	16.0	15.452	91	1092	11.2	1820	8500	12.274		⊙	⊙	⊙	(⊙)	
	20.0	20.298	69	1107	8.6	1870	8700	11.463		⊙	⊙	⊙	(⊙)	
	25.0	25.989	54	1120	6.8	1900	9000	10.963		⊙	⊙	⊙	(⊙)	
	31.5	31.429	45	1131	5.7	1920	9100	10.647		⊙	⊙	⊙	(⊙)	
40	40.476	35	744	2.9	2400	10500	10.858		⊙	⊙				
50	53.333	26	754	2.2	2450	11200	10.579		⊙	⊙				
63	66.667	21	763	1.8	2500	12000	10.340		⊙	⊙				
FRD 53 3c	40	39.333	36	1150	4.7	700	7600	10.526	⊙	⊙	⊙	⊙	(⊙)	
	50	47.984	29	1160	3.9	970	7800	13.854	⊙	⊙	⊙	⊙		
	63	59.878	23	1170	3.2	1290	7800	14.391	⊙	⊙	⊙	⊙		
	80	77.262	18	1180	2.5	1610	7900	14.087	⊙	⊙	⊙			
	100	96.280	15	1200	2.0	1820	7900	13.603	⊙	⊙	⊙			
	112	116.595	12	1200	1.7	1910	8050	13.585	⊙	⊙	⊙			
	125	129.800	11	1200	1.5	1980	8100	13.576	⊙	⊙				
	140	145.939	9.6	1200	1.3	1700	8050	13.476	⊙	⊙				
	160	157.143	8.9	1200	1.2	1450	8200	16.600	⊙	⊙				
	200	195.824	7.1	1200	1.0	1750	8400	16.328	⊙	⊙				
	225	237.143	5.9	1200	0.8	1700	8200	16.100	⊙					
	250	264.000	5.3	1200	0.7	1930	8700	15.854	⊙					
	280	296.825	4.7	1200	0.7	2000	8800	15.856	⊙					
	315	332.308	4.2	800	0.4	2100	9000	15.857	⊙					
	400	402.424	3.5	800	0.3	2400	10500	15.866	⊙					
500	503.704	2.8	800	0.3	2500	11200	15.854	⊙						
560	560.000	2.5	800	0.2	2500	11600	15.850	⊙						
630	629.630	2.2	800	0.2	2550	12000	15.847	⊙						

2c, 3c - Numero coppie di riduzione

⊙ - Solo B5

(⊙) - B5 e B14

- Number of reduction stages

- B5 only

- B5 and B14

- Anzahl der Getriebestufen

- Nur B5

- B5 u. B14

Lubrificazione (litri olio) e Pesì (kg) - Lubrication (Oil litres) and Weights (kg) - Schmierung (Öl Liter) u. Gewichte (kg)

	H	V	kg
FRD52	4.5	5.5	49
FRD53	4.5	6.5	52



Selezione Riduttore - Speed Reducer Selection - Getriebeauswahl

RD6 - 2100 Nm - 1400 rpm

	i_n	i_r	n_2 [rpm]	M_2 [Nm]	P_1 [kW]	F_{r1} [N]	F_{r2} [N]	$J_1 (x 10^{-4})$ [kgm ²]	80	90	100	112	132	160	180
FRD 62 2c	2.25	2.323	603	1149	78.2	1100	4800	85.205		⊙	⊙	⊙	(⊙)	⊙	⊙
	2.5	2.616	535	1294	78.2	1100	5100	67.187		⊙	⊙	⊙	(⊙)	⊙	⊙
	2.80	2.945	475	1249	67.0	1100	5400	58.515		⊙	⊙	⊙	(⊙)	⊙	⊙
	3.15	3.318	422	1407	67.1	1150	5600	53.914		⊙	⊙	⊙	(⊙)	⊙	⊙
	3.55	3.568	392	1324	58.7	1200	5800	49.394		⊙	⊙	⊙	(⊙)	⊙	⊙
	4.0	4.019	348	1492	58.7	1220	6000	44.341		⊙	⊙	⊙	(⊙)	⊙	⊙
	4.5	4.398	318	1399	50.3	1250	6400	42.724		⊙	⊙	⊙	(⊙)	⊙	⊙
	5.0	4.955	283	1576	50.3	1270	6700	38.909		⊙	⊙	⊙	(⊙)	⊙	⊙
	5.6	5.561	252	1427	40.6	1500	6800	42.780		⊙	⊙	⊙	(⊙)	⊙	⊙
	6.3	6.571	213	1811	43.6	2180	6900	59.890		⊙	⊙	⊙	(⊙)	⊙	⊙
	7.1	7.305	192	1261	27.3	2200	7200	45.425		⊙	⊙	⊙	(⊙)	⊙	⊙
	8.0	8.333	168	1832	34.8	2340	7800	42.332		⊙	⊙	⊙	(⊙)	⊙	⊙
	9.0	8.700	161	1145	20.8	2400	8000	40.422		⊙	⊙	⊙	(⊙)	⊙	⊙
	10.0	10.095	139	1850	29.0	2500	8300	37.192		⊙	⊙	⊙	(⊙)	⊙	⊙
	11.2	11.734	119	854	11.5	2500	9000	35.155		⊙	⊙	⊙	(⊙)	⊙	⊙
	12.5	12.444	113	1870	23.8	2600	10300	34.106		⊙	⊙	⊙	(⊙)	⊙	⊙
	16.0	15.733	89	1892	19.0	2650	12800	31.562		⊙	⊙	⊙	(⊙)	⊙	⊙
	20.0	20.667	68	1918	14.7	2700	13000	29.477		⊙	⊙	⊙	(⊙)	⊙	⊙
	25.0	24.615	57	1934	12.4	2750	13500	28.188		⊙	⊙	⊙	(⊙)	⊙	
	31.5	33.200	42	1964	9.4	2850	13700	27.378		⊙	⊙	⊙	(⊙)	⊙	
40	40.500	35	1389	5.4	3400	15700	27.919		⊙	⊙	⊙	(⊙)			
50	49.800	28	1403	4.5	3450	16800	27.203		⊙	⊙	⊙	(⊙)			
63	56.000	25	1412	4.0	3500	18000	26.590		⊙	⊙	⊙				
FRD 63 3c	40	39.708	35	2000	8.1	900	11400	27.066	⊙	⊙	⊙	⊙	(⊙)	⊙	
	50	48.948	29	2020	6.7	1400	11700	35.625	⊙	⊙	⊙	⊙	(⊙)		
	63	61.884	23	2040	5.3	1870	11700	37.004	⊙	⊙	⊙	⊙	(⊙)		
	80	81.289	17	2060	4.1	2400	11900	36.223	⊙	⊙	⊙	⊙			
	90	95.524	15	2080	3.5	2500	11900	35.602	⊙	⊙	⊙	⊙			
	100	104.082	13	2100	3.3	2600	11900	34.980	⊙	⊙	⊙	⊙			
	125	125.867	11	2100	2.7	2800	12000	34.910	⊙	⊙	⊙				
	160	157.333	9.0	2100	2.2	2100	12300	42.685	⊙	⊙	⊙				
	180	171.533	8.2	2100	2.0	2300	12500	42.338	⊙	⊙	⊙				
	200	201.571	6.9	2100	1.7	2500	12600	41.987	⊙	⊙	⊙				
	225	219.631	6.4	2100	1.5	2700	12800	41.372	⊙	⊙					
	250	265.600	5.3	2100	1.3	2800	13000	40.766	⊙	⊙					
	315	332.000	4.2	2100	1.0	3000	13500	40.774	⊙	⊙					
	355	373.333	3.1	2100	0.9	3500	15700	40.799	⊙	⊙					
	450	448.000	3.1	1650	0.6	3600	16800	40.766	⊙						
560	560.000	2.5	1650	0.5	3700	18000	40.748	⊙							

2c & 3c - Numero coppie di riduzione - Number of reduction stages - Anzahl der Getriebestufen
 ⊙ - Solo B5 - B5 only - Nur B5
 (⊙) - B5 e B14 - B5 and B14 - B5 u. B14

Lubrificazione (litri olio) e Pesì (kg) - Lubrication (Oil litres) and Weights (kg) - Schmierung (Öl Liter) u. Gewichte (kg)

	H	V	kg
FRD62	7.0	9.0	62
FRD63	7.0	11	70

Selezione Motoriduttore - Geared Motor Selection - Getriebemotorauswahl
RD
MRD - 1400 rpm

P ₁ [kW]	i _n	i _r	N ₂ [rpm]	M ₂ [Nm]	FS	Tipo - Size - Größe	F _{r2} [N]	MRD [kg]	FRD [kg]	J _m × 10 ⁻⁴	J ₁ × 10 ⁻⁴
0.06	2.25	2.314	605	1	>3.5	MRD02	750	3.0	5.9	1.50	0.4980
	2.5	2.568	545	1	>3.5	MRD02	810	3.0	5.9	1.50	0.4043
	2.8	2.952	474	1	>3.5	MRD02	820	3.0	5.9	1.50	0.3626
	3.15	3.277	427	1	>3.5	MRD02	890	3.0	5.9	1.50	0.3235
	4	4.256	329	2	>3.5	MRD02	960	3.0	5.9	1.50	0.2677
	4.5	4.753	295	2	>3.5	MRD02	940	3.0	5.9	1.50	0.2498
	5	5.276	265	2	>3.5	MRD02	1020	3.0	5.9	1.50	0.2380
	5.6	5.726	244	2	>3.5	MRD12	1620	4.8	7.7	1.50	0.9994
	6.3	6.253	224	2	>3.5	MRD02	1100	3.0	5.9	1.50	0.3088
	7.1	7.333	191	3	>3.5	MRD02	1140	3.0	5.9	1.50	0.2851
	8	7.979	175	3	>3.5	MRD02	1180	3.0	5.9	1.50	0.2649
	9	9.315	150	4	>3.5	MRD12	1810	4.8	7.7	1.50	0.9327
	10	10.362	135	4	>3.5	MRD02	1290	3.0	5.9	1.50	0.2329
	11.2	11.468	122	5	>3.5	MRD12	1860	4.8	7.7	1.50	0.8402
	12.5	12.844	109	5	>3.5	MRD02	1370	3.0	5.9	1.50	0.2153
	16	16.320	86	6	>3.5	MRD02	1480	3.0	5.9	1.50	0.2010
	20	21.533	65	8	>3.5	MRD02	1590	3.0	5.9	1.50	0.1899
	25	26.747	52	11	>3.5	MRD02	1590	3.0	5.9	1.50	0.1837
	31.5	30.222	46	12	>3.5	MRD02	1580	3.0	5.9	1.50	0.1812
	35.5	34.675	40	14	2.6	MRD02	1580	3.0	5.9	1.50	0.1881
	40	43.070	33	17	2.1	MRD02	1560	3.0	5.9	1.50	0.1826
	40	36.892	38	14	>3.5	MRD03	1570	3.2	6.1	1.50	0.1530
	40	39.083	36	15	>3.5	MRD12	1960	4.8	7.7	1.50	0.6895
	40	40.103	35	15	>3.5	MRD13	1550	4.8	7.7	1.50	0.4477
	50	48.667	29	19	1.9	MRD02	1550	3.0	5.9	1.50	0.1803
	50	47.074	30	18	2.9	MRD03	1560	3.2	6.1	1.50	0.4897
	50	48.118	29	19	3.5	MRD12	1960	4.8	7.7	1.50	0.6743
	50	52.201	27	20	>3.5	MRD13	1660	4.8	7.7	1.50	1.3193
	63	61.135	23	24	2.2	MRD03	1520	3.2	6.1	1.50	0.4807
	63	61.670	23	24	2.8	MRD12	1960	4.8	7.7	1.50	0.6681
	63	66.028	21	25	>3.5	MRD13	1790	4.8	7.7	1.50	1.3085
	80	75.782	18	29	1.8	MRD03	1480	3.2	6.1	1.50	0.4764
	80	80.432	17	31	3.2	MRD13	1930	4.8	7.7	1.50	1.2905
100	96.288	15	37	1.4	MRD03	1400	3.2	6.1	1.50	0.4735	
100	100.596	14	39	2.6	MRD13	1900	4.8	7.7	1.50	1.2861	
125	127.047	11	49	1.1	MRD03	1230	3.2	6.1	1.50	0.4717	
125	130.843	11	50	2.0	MRD13	1820	4.8	7.7	1.50	1.2833	
160	157.805	8.9	61	0.9	MRD03	970	3.2	6.1	1.50	0.4709	
160	165.075	8.5	64	1.6	MRD13	1710	4.8	7.7	1.50	1.7033	
180	178.311	7.9	69	0.8	MRD03	970	3.2	6.1	1.50	0.4708	
180	206.460	6.8	80	1.3	MRD13	1640	4.8	7.7	1.50	1.7092	
200	268.538	5.2	103	1.0	MRD13	1530	4.8	7.7	1.50	1.6996	
315	330.615	4.2	127	0.8	MRD13	1540	4.8	7.7	1.50	1.7064	
0.09	2.25	2.314	605	1	>3.5	MRD02	750	3.0	6.2	1.50	0.4980
	2.5	2.568	545	2	>3.5	MRD02	810	3.0	6.2	1.50	0.4044
	2.8	2.952	474	2	>3.5	MRD02	820	3.0	6.2	1.50	0.3626
	3.15	3.277	427	2	>3.5	MRD02	880	3.0	6.2	1.50	0.3235
	4	4.256	329	3	>3.5	MRD02	950	3.0	6.2	1.50	0.2677
	4.5	4.753	295	3	>3.5	MRD02	980	3.0	6.2	1.50	0.2498
	5	5.276	265	3	>3.5	MRD02	1010	3.0	6.2	1.50	0.2380



Selezione Motoriduttore - Geared Motor Selection - Getriebemotorauswahl

MRD - 1400 rpm

P ₁ [kW]	i _n	i _r	N ₂ [rpm]	M ₂ [Nm]	FS	Tipo - Size - Größe	F _{r2} [N]	MRD [kg]	FRD [kg]	J _m × 10 ⁻⁴	J ₁ × 10 ⁻⁴
0.09	5.6	5.726	244	3	>3.5	MRD12	1620	4.8	8.0	1.50	0.9994
	6.3	6.253	224	4	>3.5	MRD02	1080	3.0	6.2	1.50	0.3088
	7.1	7.333	191	4	>3.5	MRD02	1130	3.0	6.2	1.50	0.2891
	8	7.979	175	5	>3.5	MRD02	1170	3.0	6.2	1.50	0.2649
	9	9.315	150	5	>3.5	MRD12	1810	4.8	8.0	1.50	0.9327
	10	10.362	135	6	>3.5	MRD02	1270	3.0	6.2	1.50	0.2329
	11.2	11.468	122	7	>3.5	MRD12	1860	4.8	8.0	1.50	0.8402
	12.5	12.844	109	8	>3.5	MRD02	1350	3.0	6.2	1.50	0.2153
	16	16.320	86	10	>3.5	MRD02	1450	3.0	6.2	1.50	0.2010
	20	21.533	65	13	>3.5	MRD02	1570	3.0	6.2	1.50	0.1899
	25	26.747	52	16	>3.5	MRD02	1570	3.0	6.2	1.50	0.1837
	25	26.522	53	16	>3.5	MRD12	1960	4.8	8.0	1.50	0.6931
	31.5	30.222	46	18	2.9	MRD02	1560	3.0	6.2	1.50	0.1812
	31.5	32.653	43	19	>3.5	MRD12	1960	4.8	8.0	1.50	0.6767
	35.5	34.675	40	20	1.7	MRD02	1540	3.0	6.2	1.50	0.1881
	40	43.070	33	25	1.4	MRD02	1510	3.0	6.2	1.50	0.1826
	40	36.892	38	21	2.4	MRD03	1540	3.2	6.4	1.50	0.1530
	40	39.083	36	23	2.9	MRD12	1940	4.8	8.0	1.50	0.6890
	40	40.103	35	23	>3.5	MRD13	1820	4.8	8.0	1.50	0.4424
	50	48.667	29	29	1.3	MRD02	1490	3.0	6.2	1.50	0.1803
	50	47.074	30	27	1.9	MRD03	1500	3.2	6.4	1.50	0.4897
	50	48.118	29	28	2.4	MRD12	1940	4.8	8.0	1.50	0.6776
	50	52.201	27	30	3.2	MRD13	1940	4.8	8.0	1.50	1.3094
	63	61.135	23	35	1.5	MRD03	1420	3.2	6.4	1.50	0.4807
	63	61.670	23	36	1.9	MRD12	1900	4.8	8.0	1.50	0.6681
	63	66.028	21	38	2.5	MRD13	1900	4.8	8.0	1.50	1.2967
	80	75.782	18	44	1.2	MRD03	1310	3.2	6.4	1.50	0.4764
	80	80.432	17	46	2.1	MRD13	1850	4.8	8.0	1.50	1.2905
100	96.288	15	56	0.9	MRD03	1100	3.2	6.4	1.50	0.4735	
100	100.596	14	58	1.7	MRD13	1760	4.8	8.0	1.50	1.2861	
125	130.843	11	76	1.3	MRD13	1580	4.8	8.0	1.50	1.2833	
160	165.075	8.5	95	1.0	MRD13	1280	4.8	8.0	1.50	1.7033	
0.12	2.25	2.314	605	2	>3.5	MRD02	750	3.0	6.7	2.80	0.6596
	2.5	2.568	545	2	>3.5	MRD02	810	3.0	6.7	2.80	0.5356
	2.8	2.952	474	2	>3.5	MRD02	810	3.0	6.7	2.80	0.4932
	3.15	3.277	427	3	>3.5	MRD02	870	3.0	6.7	2.80	0.4548
	3.55	3.834	365	3	>3.5	MRD02	890	3.0	6.7	2.80	0.4338
	4	4.256	329	3	>3.5	MRD02	940	3.0	6.7	2.80	0.3989
	4.5	4.753	295	4	>3.5	MRD02	970	3.0	6.7	2.80	0.3784
	5	5.276	265	4	>3.5	MRD02	1000	3.0	6.7	2.80	0.3692
	5.6	5.726	244	5	>3.5	MRD12	1570	4.8	8.5	2.80	1.0069
	6.3	6.253	224	5	>3.5	MRD02	1070	3.0	6.7	2.80	0.4401
	7.1	7.333	191	6	>3.5	MRD02	1120	3.0	6.7	2.80	0.4135
	8	7.979	175	6	>3.5	MRD02	1160	3.0	6.7	2.80	0.3961
	9	9.315	150	7	>3.5	MRD12	1760	4.8	8.5	2.80	0.9397
	10	10.362	135	8	>3.5	MRD02	1250	3.0	6.7	2.80	0.3641
	11.2	11.468	122	9	>3.5	MRD12	1810	4.8	8.5	2.80	0.8465
	11.2	11.806	119	9	>3.5	MRD02	1260	3.0	6.7	2.80	0.3517
	12.5	12.844	109	10	>3.5	MRD02	1330	3.0	6.7	2.80	0.3466
	16	16.320	86	13	>3.5	MRD02	1420	3.0	6.7	2.80	0.3323

Selezione Motoriduttore - Geared Motor Selection - Getriebemotorauswahl
RD
MRD - 1400 rpm

P ₁ [kW]	i _n	i _r	N ₂ [rpm]	M ₂ [Nm]	FS	Tipo - Size - Größe	F _{r2} [N]	MRD [kg]	FRD [kg]	J _m × 10 ⁻⁴	J ₁ × 10 ⁻⁴
0.12	20	21.533	65	17	>3.5	MRD02	1530	3.0	6.7	2.80	0.3211
	20	20.391	69	16	>3.5	MRD12	1810	4.8	8.5	2.80	0.7283
	25	26.747	52	21	2.5	MRD02	1550	3.0	6.7	2.80	0.3150
	25	26.522	53	21	>3.5	MRD12	1900	4.8	8.5	2.80	0.6983
	31.5	30.222	46	24	2.2	MRD02	1530	3.0	6.7	2.80	0.3124
	31.5	32.653	43	26	>3.5	MRD12	1900	4.8	8.5	2.80	0.6818
	35.5	34.675	40	27	1.3	MRD02	1510	3.0	6.7	2.80	0.3194
	40	43.070	33	34	1.0	MRD02	1450	3.0	6.7	2.80	0.3138
	40	36.892	38	28	1.8	MRD03	1500	3.2	6.9	2.80	0.1499
	40	39.083	36	31	2.1	MRD12	1910	4.8	8.5	2.80	0.6867
	40	40.103	35	31	3.1	MRD13	1940	4.8	8.5	2.80	0.4521
	40	40.759	34	31	>3.5	MRD23	2990	8.5	12.2	2.80	1.4526
	50	48.667	29	38	0.9	MRD02	1410	3.0	6.7	2.80	0.3115
	50	47.074	30	36	1.4	MRD03	1430	3.2	6.9	2.80	0.4865
	50	48.118	29	38	1.8	MRD12	1910	4.8	8.5	2.80	0.6753
	50	52.201	27	40	2.4	MRD13	1900	4.8	8.5	2.80	1.4775
	50	52.172	27	40	>3.5	MRD23	3120	8.5	12.2	2.80	2.1338
	63	61.135	23	47	1.1	MRD03	1300	3.2	6.9	2.80	0.4775
	63	61.670	23	48	1.4	MRD12	1850	4.8	8.5	2.80	0.6658
	63	66.028	21	51	1.9	MRD13	1840	4.8	8.5	2.80	1.4648
	63	64.256	22	50	>3.5	MRD23	3250	8.5	12.2	2.80	2.1157
	80	75.782	18	58	0.9	MRD03	1100	3.2	6.9	2.80	0.4733
	80	80.432	17	62	1.6	MRD13	1750	4.8	8.5	2.80	1.4586
	80	81.519	17	63	3.2	MRD23	3300	8.5	12.2	2.80	2.0939
	100	100.596	14	77	1.3	MRD13	1600	4.8	8.5	2.80	1.4542
	100	105.431	13	81	2.5	MRD23	3250	8.5	12.2	2.80	2.0832
	125	130.843	11	101	1.0	MRD13	1270	4.8	8.5	2.80	1.4513
	125	124.159	11	96	2.1	MRD23	3150	8.5	12.2	2.80	2.0798
	160	165.075	8.5	127	0.8	MRD13	1100	4.8	8.5	2.80	1.8714
	160	164.938	8.5	127	1.6	MRD23	2950	8.5	12.2	2.80	2.6601
	200	209.250	6.7	161	1.2	MRD23	2650	8.5	12.2	2.80	2.6491
250	270.630	5.2	208	1.0	MRD23	1980	8.5	12.2	2.80	2.6418	
315	318.704	4.4	246	0.8	MRD23	1600	8.5	12.2	2.80	2.6399	
0.18	2.25	2.314	605	3	>3.5	MRD02	740	3.0	7.2	4.00	0.6596
	2.5	2.568	545	3	>3.5	MRD02	800	3.0	7.2	4.00	0.5356
	2.8	2.952	474	3	>3.5	MRD02	800	3.0	7.2	4.00	0.4932
	3.15	3.277	427	4	>3.5	MRD02	860	3.0	7.2	4.00	0.4548
	3.55	3.834	365	5	>3.5	MRD02	880	3.0	7.2	4.00	0.4338
	4	4.256	329	5	>3.5	MRD02	920	3.0	7.2	4.00	0.3989
	4.5	4.753	295	6	>3.5	MRD02	940	3.0	7.2	4.00	0.3784
	5	5.276	265	6	>3.5	MRD02	980	3.0	7.2	4.00	0.3692
	5.6	5.726	244	7	>3.5	MRD12	1530	4.8	9.0	4.00	0.9994
	6.3	6.253	224	7	>3.5	MRD02	1050	3.0	7.2	4.00	0.4401
	7.1	7.333	191	9	>3.5	MRD02	1090	3.0	7.2	4.00	0.4135
	7.1	7.161	196	8	>3.5	MRD12	1630	4.8	9.0	4.00	1.0450
	8	7.979	175	9	>3.5	MRD02	1130	3.0	7.2	4.00	0.3961
	9	9.315	150	11	>3.5	MRD12	1720	4.8	9.0	4.00	0.9327
	9	9.524	147	11	>3.5	MRD02	1170	3.0	7.2	4.00	0.3727
	10	10.362	135	12	>3.5	MRD02	1210	3.0	7.2	4.00	0.3641
	11.2	11.468	122	14	2.6	MRD12	1770	4.8	9.0	4.00	0.8402



Selezione Motoriduttore - Geared Motor Selection - Getriebemotorauswahl

MRD - 1400 rpm

P ₁ [kW]	i _n	i _r	N ₂ [rpm]	M ₂ [Nm]	FS	Tipo - Size - Größe	F _{r2} [N]	MRD [kg]	FRD [kg]	J _m × 10 ⁻⁴	J ₁ × 10 ⁻⁴
0.18	11.2	11.806	119	14	>3.5	MRD02	1220	3.0	7.2	4.00	0.3517
	12.5	12.844	109	15	3.3	MRD02	1280	3.0	7.2	4.00	0.3466
	12.5	13.384	105	16	>3.5	MRD12	1790	4.8	9.0	4.00	0.8027
	16	16.320	86	19	2.7	MRD02	1360	3.0	7.2	4.00	0.3323
	16	16.309	86	19	>3.5	MRD12	1790	4.8	9.0	4.00	0.7594
	20	21.533	65	25	2.0	MRD02	1460	3.0	7.2	4.00	0.3211
	20	20.391	69	24	>3.5	MRD12	1810	4.8	9.0	4.00	0.7229
	25	26.747	52	32	1.6	MRD02	1480	3.0	7.2	4.00	0.3150
	25	26.522	53	31	3.0	MRD12	1940	4.8	9.0	4.00	0.6894
	31.5	30.222	46	36	1.5	MRD02	1440	3.0	7.2	4.00	0.3124
	31.5	32.653	43	39	2.4	MRD12	1910	4.8	9.0	4.00	0.6771
	35.5	34.675	40	41	0.9	MRD02	1390	3.0	7.2	4.00	0.3194
	40	36.892	38	43	1.2	MRD03	1370	3.2	7.4	4.00	0.1499
	40	39.083	36	46	1.4	MRD12	1800	4.8	9.0	4.00	0.6867
	40	40.103	35	46	2.0	MRD13	1870	4.8	9.0	4.00	0.4521
	40	40.759	34	47	>3.5	MRD23	3220	8.5	12.7	4.00	1.4526
	50	47.074	30	54	1.0	MRD03	1200	3.2	7.4	4.00	0.4865
	50	48.118	29	57	1.2	MRD12	1800	4.8	9.0	4.00	0.6753
	50	52.201	27	60	1.6	MRD13	1770	4.8	9.0	4.00	1.4775
	50	52.172	27	60	3.2	MRD23	3330	8.5	12.7	4.00	2.1312
	63	61.135	23	71	0.7	MRD03	1200	3.2	7.4	4.00	0.4797
	63	61.670	23	73	0.9	MRD12	1670	4.8	9.0	4.00	0.6658
	63	66.028	21	76	1.3	MRD13	1630	4.8	9.0	4.00	1.4648
	63	64.256	22	74	2.6	MRD23	3280	8.5	12.7	4.00	2.1092
	80	80.432	17	93	1.1	MRD13	1420	4.8	9.0	4.00	1.4586
	80	81.519	17	94	2.1	MRD23	3190	8.5	12.7	4.00	2.0939
	100	100.596	14	116	0.9	MRD13	1200	4.8	9.0	4.00	1.4542
	100	105.431	13	122	1.6	MRD23	3000	8.5	12.7	4.00	2.0832
125	124.159	11	143	1.4	MRD23	2850	8.5	12.7	4.00	2.0798	
160	164.938	8.5	191	1.0	MRD23	2280	8.5	12.7	4.00	2.6601	
200	209.250	6.7	242	0.8	MRD23	1500	8.5	12.7	4.00	2.6491	
0.25	2.25	2.314	605	4	>3.5	MRD02	720	3.0	8.0	5.00	0.6467
	2.5	2.568	545	4	>3.5	MRD02	780	3.0	8.0	5.00	0.5251
	2.8	2.952	474	5	>3.5	MRD02	780	3.0	8.0	5.00	0.4835
	3.15	3.277	427	5	>3.5	MRD02	840	3.0	8.0	5.00	0.4443
	3.55	3.834	365	6	>3.5	MRD02	860	3.0	8.0	5.00	0.4253
	4	4.256	329	7	>3.5	MRD02	900	3.0	8.0	5.00	0.3587
	4.5	4.753	295	8	>3.5	MRD02	930	3.0	8.0	5.00	0.3674
	5	5.276	265	9	>3.5	MRD02	960	3.0	8.0	5.00	0.3587
	5	5.073	276	8	>3.5	MRD12	1540	4.8	9.8	5.00	0.8146
	5.6	5.726	244	9	>3.5	MRD12	1600	4.8	9.8	5.00	0.9167
	5.6	5.747	244	9	>3.5	MRD02	1000	3.0	8.0	5.00	0.3841
	6.3	6.253	224	10	>3.5	MRD02	1020	3.0	8.0	5.00	0.4296
	7.1	7.333	191	12	>3.5	MRD02	1060	3.0	8.0	5.00	0.4015
	7.1	7.161	196	12	>3.5	MRD12	1720	4.8	9.8	5.00	0.9664
	8	7.979	175	13	>3.5	MRD02	1100	3.0	8.0	5.00	0.3856
	9	9.315	150	15	2.9	MRD12	1830	4.8	9.8	5.00	0.8696
	9	9.524	147	16	>3.5	MRD02	1140	3.0	8.0	5.00	0.3618
	9	9.203	152	15	>3.5	MRD22	2240	7.9	12.9	5.00	1.7670
	10	10.362	135	17	2.9	MRD02	1170	3.0	8.0	5.00	0.3536

Selezione Motoriduttore - Geared Motor Selection - Getriebemotorauswahl
RD
MRD - 1400 rpm

P ₁ [kW]	i _n	i _r	N ₂ [rpm]	M ₂ [Nm]	FS	Tipo - Size - Größe	F _{r2} [N]	MRD [kg]	FRD [kg]	J _m × 10 ⁻⁴	J ₁ × 10 ⁻⁴
0.25	10	10.581	132	17	>3.5	MRD12	1900	4.8	9.8	5.00	0.8219
	11.2	11.468	122	19	1.9	MRD12	1920	4.8	9.8	5.00	0.7959
	11.2	11.806	119	19	2.8	MRD02	1180	3.0	8.0	5.00	0.3415
	11.2	11.859	118	19	3.1	MRD22	2370	7.9	12.9	5.00	1.6113
	12.5	12.844	109	21	2.4	MRD02	1230	3.0	8.0	5.00	0.3361
	12.5	13.384	105	22	>3.5	MRD12	1940	4.8	9.8	5.00	0.7664
	16	16.320	86	27	1.9	MRD02	1300	3.0	8.0	5.00	0.3218
	16	16.309	86	27	3.4	MRD12	1960	4.8	9.8	5.00	0.7295
	20	21.533	65	35	1.4	MRD02	1370	3.0	8.0	5.00	0.3106
	20	20.391	69	33	2.8	MRD12	1930	4.8	9.8	5.00	0.7019
	20	20.667	68	34	>3.5	MRD22	2640	7.9	12.9	5.00	1.3981
	25	26.747	52	44	1.2	MRD02	1370	3.0	8.0	5.00	0.3045
	25	26.522	53	43	2.1	MRD12	1890	4.8	9.8	5.00	0.6796
	25	26.729	52	44	>3.5	MRD22	2750	7.9	12.9	5.00	1.3443
	31.5	30.222	46	49	1.1	MRD02	1330	3.0	8.0	5.00	0.3019
	31.5	32.653	43	53	1.8	MRD12	1840	4.8	9.8	5.00	0.6672
	31.5	31.477	44	52	>3.5	MRD22	2860	7.9	12.9	5.00	1.3211
	40	36.892	38	59	0.9	MRD03	1140	3.2	8.2	5.00	0.1763
	40	39.083	36	64	1.0	MRD12	1630	4.8	9.8	5.00	0.6769
	40	40.103	35	64	1.5	MRD13	1750	4.8	9.8	5.00	0.4422
	40	39.388	36	65	2.0	MRD22	3320	7.9	12.9	5.00	1.2877
	40	40.759	34	65	2.9	MRD23	2000	8.5	13.5	5.00	1.3104
	40	38.571	36	63	>3.5	MRD32	7790	13.5	18.5	5.00	1.9547
	50	48.118	29	79	0.9	MRD12	1630	4.8	9.8	5.00	0.6654
	50	52.201	27	84	1.1	MRD13	1580	4.8	9.8	5.00	1.4676
	50	50.758	28	83	1.6	MRD22	3250	7.9	12.9	5.00	1.3030
	50	52.172	27	84	2.3	MRD23	3250	8.5	13.5	5.00	2.1312
	50	50.727	28	83	3.3	MRD32	7950	13.5	18.5	5.00	1.8570
	50	48.772	29	78	>3.5	MRD33	7260	14.5	19.5	5.00	4.4851
	63	66.028	21	106	0.9	MRD13	1260	4.8	9.8	5.00	1.4549
	63	62.127	23	102	1.3	MRD22	3170	7.9	12.9	5.00	1.2810
	63	64.256	22	103	1.9	MRD23	3150	8.5	13.5	5.00	2.1092
	63	63.333	22	104	2.7	MRD32	7850	13.5	18.5	5.00	1.7865
	63	64.836	22	104	>3.5	MRD33	7430	14.5	19.5	5.00	4.8513
	63	63.747	22	102	>3.5	MRD43	7280	21.5	26.5	5.00	7.0925
	80	80.432	17	129	0.8	MRD13	1330	4.8	9.8	5.00	1.4566
	80	81.519	17	131	1.5	MRD23	2950	8.5	13.5	5.00	2.0939
	80	76.310	18	122	3.4	MRD33	7800	14.5	19.5	5.00	4.6584
	80	82.254	17	132	>3.5	MRD43	7280	21.5	26.5	5.00	6.9428
	100	105.431	13	169	1.2	MRD23	2650	8.5	13.5	5.00	2.0832
	100	99.535	14	160	2.6	MRD33	7600	14.5	19.5	5.00	4.3194
	100	102.502	14	165	>3.5	MRD43	7420	21.5	26.5	5.00	6.7045
125	124.159	11	199	1.0	MRD23	2250	8.5	13.5	5.00	2.0798	
125	130.903	11	210	2.0	MRD33	7200	14.5	19.5	5.00	4.3033	
125	124.129	11	199	3.3	MRD43	7700	21.5	26.5	5.00	6.6730	
160	164.938	8.5	265	0.8	MRD23	2320	8.5	13.5	5.00	2.5729	
160	167.799	8.3	269	1.6	MRD33	6500	14.5	19.5	5.00	6.4724	
160	160.689	8.7	258	2.5	MRD43	9800	21.5	26.5	5.00	8.8326	
200	197.495	7.1	317	1.3	MRD33	5900	14.5	19.5	5.00	6.2820	
200	207.341	6.8	333	2.0	MRD43	9600	21.5	26.5	5.00	8.6391	



Selezione Motoriduttore - Geared Motor Selection - Getriebemotorauswahl

MRD - 1400 rpm

P ₁ [kW]	i _n	i _r	N ₂ [rpm]	M ₂ [Nm]	FS	Tipo - Size - Größe	F _{r2} [N]	MRD [kg]	FRD [kg]	J _m × 10 ⁻⁴	J ₁ × 10 ⁻⁴
0.25	250	257.602	5.4	413	1.0	MRD33	3600	14.5	19.5	5.00	5.9420
	250	258.379	5.4	415	1.6	MRD43	9100	21.5	26.5	5.00	8.2999
	315	307.214	4.6	493	0.9	MRD33	2700	14.5	19.5	5.00	5.9472
	315	312.297	4.5	501	1.3	MRD43	8000	21.5	26.5	5.00	8.3020
0.37	2.25	2.314	605	6	>3.5	MRD02	710	3.0	8.8	8.00	0.6467
	2.5	2.568	545	6	>3.5	MRD02	760	3.0	8.8	8.00	0.5251
	2.8	2.952	474	7	>3.5	MRD02	760	3.0	8.8	8.00	0.4835
	3.15	3.277	427	8	>3.5	MRD02	820	3.0	8.8	8.00	0.4443
	3.15	3.081	454	7	>3.5	MRD12	1370	4.8	10.6	8.00	1.1385
	3.55	3.834	365	9	>3.5	MRD02	830	3.0	8.8	8.00	0.4253
	3.55	3.716	377	9	>3.5	MRD12	1420	4.8	10.6	8.00	0.9920
	4	4.256	329	10	3.5	MRD02	870	3.0	8.8	8.00	0.3587
	4	4.011	349	10	>3.5	MRD12	1470	4.8	10.6	8.00	0.9383
	4.5	4.753	295	12	3.0	MRD02	890	3.0	8.8	8.00	0.3674
	4.5	4.700	298	11	>3.5	MRD12	1530	4.8	10.6	8.00	0.9732
	5	5.276	265	13	3.0	MRD02	920	3.0	8.8	8.00	0.3587
	5	5.073	276	12	>3.5	MRD12	1580	4.8	10.6	8.00	0.8280
	5.6	5.726	244	14	>3.5	MRD12	1630	4.8	10.6	8.00	0.9242
	5.6	5.747	244	14	>3.5	MRD02	960	3.0	8.8	8.00	0.3841
	6.3	6.253	224	15	3.2	MRD02	980	3.0	8.8	8.00	0.4296
	6.3	6.686	209	16	>3.5	MRD12	1700	4.8	10.6	8.00	1.0363
	7.1	7.333	191	18	3.0	MRD02	1010	3.0	8.8	8.00	0.4015
	7.1	7.161	196	17	3.1	MRD12	1750	4.8	10.6	8.00	0.9743
	7.1	7.115	197	17	>3.5	MRD22	2390	7.9	13.7	8.00	2.0610
	8	7.979	175	19	2.5	MRD02	1040	3.0	8.8	8.00	0.3856
	8	8.129	172	20	>3.5	MRD12	1800	4.8	10.6	8.00	0.9227
	9	9.315	150	23	2.0	MRD12	1870	4.8	10.6	8.00	0.8696
	9	9.524	147	23	2.3	MRD02	1070	3.0	8.8	8.00	0.3618
	9	9.203	152	22	>3.5	MRD22	2550	7.9	13.7	8.00	1.7670
	10	10.362	135	25	2.0	MRD02	1100	3.0	8.8	8.00	0.3536
	10	10.581	132	26	3.5	MRD12	1960	4.8	10.6	8.00	0.8159
	11.2	11.468	122	28	1.3	MRD12	1960	4.8	10.6	8.00	0.7896
	11.2	11.806	119	29	1.9	MRD02	1100	3.0	8.8	8.00	0.3415
	11.2	11.859	118	29	2.1	MRD22	2690	7.9	13.7	8.00	1.6113
	12.5	12.844	109	31	1.6	MRD02	1140	3.0	8.8	8.00	0.3361
	12.5	13.384	105	32	2.8	MRD12	1940	4.8	10.6	8.00	0.7619
	12.5	13.227	106	32	>3.5	MRD22	2750	7.9	13.7	8.00	1.5544
	16	16.320	86	40	1.3	MRD02	1180	3.0	8.8	8.00	0.3218
	16	16.309	86	40	2.3	MRD12	1910	4.8	10.6	8.00	0.7295
	16	16.290	86	39	>3.5	MRD22	2880	7.9	13.7	8.00	1.4684
20	21.533	65	52	1.0	MRD02	1220	3.0	8.8	8.00	0.3106	
20	20.391	69	49	1.9	MRD12	1860	4.8	10.6	8.00	0.7019	
20	20.667	68	50	>3.5	MRD22	3000	7.9	13.7	8.00	1.3981	
25	26.747	52	65	0.8	MRD02	1020	3.0	8.8	8.00	0.3045	
25	26.522	53	64	1.4	MRD12	1760	4.8	10.6	8.00	0.6796	
25	26.729	52	65	2.9	MRD22	3320	7.9	13.7	8.00	1.3507	
31.5	32.653	43	79	1.2	MRD12	1630	4.8	10.6	8.00	0.6672	
31.5	31.477	44	76	2.5	MRD22	3280	7.9	13.7	8.00	1.3210	
31.5	33.214	42	81	>3.5	MRD32	7570	13.5	19.3	8.00	1.8632	
40	40.103	35	95	1.0	MRD13	1580	4.8	10.6	8.00	0.4422	

Selezione Motoriduttore - Geared Motor Selection - Getriebemotorauswahl
RD
MRD - 1400 rpm

P ₁ [kW]	i _n	i _r	N ₂ [rpm]	M ₂ [Nm]	FS	Tipo - Size - Größe	F _{r2} [N]	MRD [kg]	FRD [kg]	J _m × 10 ⁻⁴	J ₁ × 10 ⁻⁴
0.37	40	39.388	36	95	1.4	MRD22	3200	7.9	13.7	8.00	1.2877
	40	40.759	34	97	2.0	MRD23	2000	8.5	14.3	8.00	1.3104
	40	38.571	36	93	2.9	MRD32	7900	13.5	19.3	8.00	1.9845
	40	38.063	37	90	>3.5	MRD33	7240	14.5	20.3	8.00	2.2180
	40	41.875	33	99	>3.5	MRD43	9500	21.5	27.3	8.00	5.2629
	50	52.201	27	124	0.8	MRD13	1500	4.8	10.6	8.00	1.4676
	50	50.758	28	123	1.1	MRD22	3040	7.9	13.7	8.00	1.3030
	50	52.172	27	124	1.6	MRD23	2800	8.5	14.3	8.00	2.1312
	50	50.727	28	123	2.2	MRD32	7800	13.5	19.3	8.00	1.8570
	50	48.772	29	116	3.5	MRD33	7420	14.5	20.3	8.00	4.4851
	50	51.084	27	121	>3.5	MRD43	9690	21.5	27.3	8.00	6.9271
	63	62.127	23	151	0.9	MRD22	2820	7.9	13.7	8.00	1.2810
	63	64.256	22	153	1.3	MRD23	2350	8.5	14.3	8.00	2.1092
	63	63.333	22	154	1.8	MRD32	7600	13.5	19.3	8.00	1.7865
	63	64.836	22	154	2.7	MRD33	7600	14.5	20.3	8.00	4.8573
	63	63.747	22	151	>3.5	MRD43	9880	21.5	27.3	8.00	7.1953
	80	81.519	17	194	1.0	MRD23	1500	8.5	14.3	8.00	2.0939
	80	76.310	18	181	2.3	MRD33	7400	14.5	20.3	8.00	4.6584
	80	82.254	17	195	3.2	MRD43	9900	21.5	27.3	8.00	7.0373
	100	105.431	13	250	0.8	MRD23	1200	8.5	14.3	8.00	2.0832
	100	99.535	14	236	1.8	MRD33	6900	14.5	20.3	8.00	4.3194
	100	102.502	14	243	2.7	MRD43	9800	21.5	27.3	8.00	6.6923
	125	130.903	11	311	1.4	MRD33	6000	14.5	20.3	8.00	4.3033
	125	124.129	11	295	2.2	MRD43	7700	21.5	27.3	8.00	6.6730
	160	167.799	8.3	399	1.1	MRD33	4100	14.5	20.3	8.00	6.4724
	160	160.689	8.7	382	1.7	MRD43	9400	21.5	27.3	8.00	8.8326
	200	197.495	7.1	469	0.9	MRD33	3500	14.5	20.3	8.00	6.2820
200	207.341	6.8	493	1.3	MRD43	8100	21.5	27.3	8.00	8.6391	
250	258.379	5.4	614	1.1	MRD43	6000	21.5	27.3	8.00	8.2999	
315	312.297	4.5	742	0.9	MRD43	5000	21.5	27.3	8.00	8.3020	
0.55	2.25	2.314	605	8	3.2	MRD02	680	3.0	11.1	14.00	0.7760
	2.25	2.348	596	8	>3.5	MRD12	1450	4.8	12.9	14.00	2.0782
	2.5	2.568	545	9	3.2	MRD02	730	3.0	11.1	14.00	0.6362
	2.5	2.534	552	9	>3.5	MRD12	1590	4.8	12.9	14.00	1.7843
	2.8	2.952	474	11	2.8	MRD02	730	3.0	11.1	14.00	0.5947
	2.8	2.855	490	10	>3.5	MRD12	1660	4.8	12.9	14.00	0.1690
	3.15	3.277	427	12	2.8	MRD02	780	3.0	11.1	14.00	0.5554
	3.15	3.081	454	11	>3.5	MRD12	1740	4.8	12.9	14.00	1.4931
	3.55	3.834	365	14	2.5	MRD02	790	3.0	11.1	14.00	0.5401
	3.55	3.716	377	13	3.4	MRD12	1810	4.8	12.9	14.00	1.3010
	4	4.256	329	15	2.3	MRD02	820	3.0	11.1	14.00	0.4995
	4	4.011	349	14	3.3	MRD12	1889	4.8	12.9	14.00	1.2685
	4.5	4.753	295	17	2.0	MRD02	840	3.0	11.1	14.00	0.4776
	4.5	4.700	298	17	2.9	MRD12	1940	4.8	12.9	14.00	1.3450
	4.5	4.554	307	16	>3.5	MRD22	2080	7.9	16.0	14.00	2.4080
	5	5.276	265	19	2.0	MRD02	870	3.0	11.1	14.00	0.4698
	5	5.073	276	18	2.7	MRD12	1980	4.8	12.9	14.00	1.1726
	5	5.013	279	18	>3.5	MRD22	2210	7.9	16.0	14.00	2.3343
	5.6	5.726	244	21	2.5	MRD12	1960	4.8	12.9	14.00	1.2924
	5.6	5.747	244	21	2.5	MRD02	840	3.0	11.1	14.00	0.4955



Selezione Motoriduttore - Geared Motor Selection - Getriebemotorauswahl

MRD - 1400 rpm

P ₁ [kW]	i _n	i _r	N ₂ [rpm]	M ₂ [Nm]	FS	Tipo - Size - Größe	F _{r2} [N]	MRD [kg]	FRD [kg]	J _m × 10 ⁻⁴	J ₁ × 10 ⁻⁴
0.55	5.6	5.609	250	20	>3.5	MRD22	2290	7.9	16.0	14.00	2.7080
	6.3	6.253	224	23	2.1	MRD02	910	3.0	11.1	14.00	0.5407
	6.3	6.686	209	24	>3.5	MRD12	1940	4.8	12.9	14.00	1.4207
	7.1	7.333	191	26	2.0	MRD02	940	3.0	11.1	14.00	0.5139
	7.1	7.161	196	26	2.1	MRD12	1930	4.8	12.9	14.00	1.3278
	7.1	7.115	197	26	>3.5	MRD22	2480	7.9	16.0	14.00	2.8273
	8	7.979	175	29	1.7	MRD02	960	3.0	11.1	14.00	0.4967
	8	8.129	172	29	3.0	MRD12	1950	4.8	12.9	14.00	1.2435
	8	8.267	169	30	>3.5	MRD22	2600	7.9	16.0	14.00	2.5853
	9	9.315	150	34	1.3	MRD12	1940	4.8	12.9	14.00	1.1361
	9	9.524	147	34	1.6	MRD02	970	3.0	11.1	14.00	0.4703
	9	9.203	152	33	2.5	MRD22	2650	7.9	16.0	14.00	2.4240
	10	10.362	135	37	1.3	MRD02	980	3.0	11.1	14.00	0.4647
	10	10.581	132	38	2.3	MRD12	1920	4.8	12.9	14.00	1.1569
	10	10.333	135	37	>3.5	MRD22	2730	7.9	16.0	14.00	2.3289
	11.2	11.468	122	41	0.8	MRD12	1900	4.8	12.9	14.00	1.1371
	11.2	11.806	119	43	1.3	MRD02	980	3.0	11.1	14.00	0.4440
	11.2	11.859	118	43	1.4	MRD22	2800	7.9	16.0	14.00	2.2104
	11.2	11.049	127	40	>3.5	MRD42	7080	20.0	28.1	14.00	5.8629
	12.5	12.844	109	46	1.1	MRD02	1010	3.0	11.1	14.00	0.4472
	12.5	13.384	105	48	1.9	MRD12	1870	4.8	12.9	14.00	1.1028
	12.5	13.227	106	48	>3.5	MRD22	2860	7.9	16.0	14.00	2.1323
	16	16.320	86	59	0.9	MRD02	1010	3.0	11.1	14.00	0.4329
	16	16.309	86	59	1.5	MRD12	1800	4.8	12.9	14.00	1.0704
	16	16.290	86	59	3.1	MRD22	3253	7.9	16.0	14.00	2.0125
	20	20.391	69	73	1.3	MRD12	1660	4.8	12.9	14.00	1.0429
	20	20.667	68	74	2.5	MRD22	3290	7.9	16.0	14.00	1.9223
	20	19.362	72	70	>3.5	MRD32	6970	13.5	21.6	14.00	3.0791
	25	26.522	53	96	1.0	MRD12	1430	4.8	12.9	14.00	0.6741
	25	26.729	52	96	2.0	MRD22	3200	7.9	16.0	14.00	1.8534
	25	25.255	55	91	>3.5	MRD32	7470	13.5	21.6	14.00	2.5278
	31.5	32.653	43	118	0.8	MRD12	1020	4.8	12.9	14.00	0.6741
	31.5	31.477	44	113	1.7	MRD22	3100	7.9	16.0	14.00	1.8236
	31.5	33.214	42	120	2.9	MRD32	7800	13.5	21.6	14.00	2.3727
	31.5	29.643	47	107	>3.5	MRD42	10070	20.0	28.1	14.00	4.4870
	40	39.388	36	142	0.9	MRD22	2900	7.9	16.0	14.00	1.7903
	40	40.759	34	144	1.3	MRD23	1870	8.5	16.6	14.00	1.7099
	40	38.571	36	139	1.9	MRD32	7700	13.5	21.6	14.00	2.4830
	40	41.538	34	150	2.6	MRD42	10700	20.0	28.1	14.00	4.5875
	40	38.063	37	134	3.0	MRD33	1940	14.5	22.6	14.00	2.5282
	40	41.875	33	148	>3.5	MRD43	9400	21.5	29.6	14.00	5.2629
	50	50.758	28	183	0.7	MRD22	3050	7.9	16.0	14.00	1.7930
	50	52.172	27	184	1.1	MRD23	2450	8.5	16.6	14.00	2.5308
	50	50.727	28	183	1.5	MRD32	7400	13.5	21.6	14.00	2.3555
	50	50.303	28	181	2.1	MRD42	10600	20.0	28.1	14.00	4.3886
	50	48.772	29	172	2.4	MRD33	7500	14.5	22.6	14.00	4.8058
	50	51.084	27	180	3.4	MRD43	9590	21.5	29.6	14.00	6.9271
	63	64.256	22	227	0.9	MRD23	1800	8.5	16.6	14.00	2.5088
	63	63.333	22	228	1.2	MRD32	7000	13.5	21.6	14.00	2.2850
	63	62.963	22	227	1.7	MRD42	10300	20.0	28.1	14.00	4.2181

Selezione Motoriduttore - Geared Motor Selection - Getriebemotorauswahl
RD
MRD - 1400 rpm

P ₁ [kW]	i _n	i _r	N ₂ [rpm]	M ₂ [Nm]	FS	Tipo - Size - Größe	F _{r2} [N]	MRD [kg]	FRD [kg]	J _m × 10 ⁻⁴	J ₁ × 10 ⁻⁴
0.55	63	64.836	22	229	1.8	MRD33	7000	14.5	22.6	14.00	4.8220
	63	63.747	22	225	2.8	MRD43	9800	21.5	29.6	14.00	7.2550
	63	59.878	23	211	>3.5	MRD53	7800	52.0	60.1	14.00	14.3910
	80	76.310	18	269	1.6	MRD33	6500	14.5	22.6	14.00	4.9660
	80	82.254	17	290	2.2	MRD43	9700	21.5	29.6	14.00	7.0373
	80	77.262	18	273	>3.5	MRD53	7900	52.0	60.1	14.00	14.0870
	100	99.535	14	351	1.2	MRD33	5200	14.5	22.6	14.00	5.1610
	100	102.502	14	362	1.8	MRD43	9500	21.5	29.6	14.00	6.6923
	100	96.280	15	340	3.5	MRD53	7900	52.0	60.1	14.00	13.6030
	100	104.082	13	368	>3.5	MRD63	11900	70.0	78.1	14.00	34.9800
	112	116.595	12	412	2.9	MRD53	8050	52.0	60.1	14.00	13.5850
	125	130.903	11	462	0.9	MRD33	4200	14.5	22.6	14.00	5.3598
	125	124.129	11	438	1.5	MRD43	7200	21.5	29.6	14.00	6.6730
	125	129.800	11	458	2.6	MRD53	8100	52.0	60.1	14.00	13.5760
	125	125.867	11	444	>3.5	MRD63	12000	70.0	78.1	14.00	34.9100
	140	145.939	9.6	515	2.3	MRD53	8050	52.0	60.1	14.00	13.4760
	160	160.689	8.7	567	1.1	MRD43	7000	21.5	29.6	14.00	8.8326
	160	157.143	8.9	555	2.2	MRD53	8200	52.0	60.1	14.00	16.6000
	160	157.333	8.9	556	>3.5	MRD63	12300	70.0	78.1	14.00	42.6850
	180	171.533	8.2	606	3.5	MRD63	12500	70.0	78.1	14.00	42.3380
	200	207.341	6.8	732	0.9	MRD43	9000	21.5	29.6	14.00	8.6391
	200	195.824	7.1	691	1.7	MRD53	8400	52.0	60.1	14.00	16.3280
	200	201.571	6.9	712	3.0	MRD63	12600	70.0	78.1	14.00	41.9870
	225	237.143	5.9	837	1.4	MRD53	8200	52.0	60.1	14.00	16.1000
	225	219.631	6.4	775	2.7	MRD63	12800	70.0	78.1	14.00	41.3720
	250	264.000	5.3	932	1.3	MRD53	8700	52.0	60.1	14.00	15.8540
250	265.600	5.3	938	2.2	MRD63	13000	70.0	78.1	14.00	40.7660	
280	296.825	4.7	1048	1.1	MRD53	8800	52.0	60.1	14.00	15.8560	
315	332.000	4.2	1172	1.8	MRD63	13500	70.0	78.1	14.00	40.7740	
355	373.333	3.8	1318	1.6	MRD63	15700	70.0	78.1	14.00	40.7990	
450	448.000	3.1	1582	1.0	MRD63	16800	70.0	78.1	14.00	40.7660	
0.75	2.25	2.314	605	11	2.4	MRD02	650	3.0	12.1	17.00	0.7760
	2.25	2.348	596	12	3.5	MRD12	1500	4.8	13.9	17.00	1.8185
	2.5	2.568	545	13	2.4	MRD02	700	3.0	12.1	17.00	0.6362
	2.5	2.534	552	12	3.2	MRD12	1680	4.8	13.9	17.00	1.6146
	2.8	2.952	474	15	2.1	MRD02	690	3.0	12.1	17.00	0.5947
	2.8	2.855	490	14	3.1	MRD12	1700	4.8	13.9	17.00	0.1584
	2.8	2.846	492	14	>3.5	MRD22	1560	7.9	17.0	17.00	3.3204
	3.15	3.277	427	16	2.0	MRD02	730	3.0	12.1	17.00	0.5554
	3.15	3.081	454	15	2.8	MRD12	1713	4.8	13.9	17.00	1.4326
	3.15	3.133	447	15	>3.5	MRD22	1760	7.9	17.0	17.00	3.1025
	3.55	3.834	365	19	1.8	MRD02	740	3.0	12.1	17.00	0.5401
	3.55	3.716	377	18	2.5	MRD12	1770	4.8	13.9	17.00	1.3010
	3.55	3.558	393	17	>3.5	MRD22	1820	7.9	17.0	17.00	2.8146
	4	4.256	329	21	1.7	MRD02	760	3.0	12.1	17.00	0.4995
	4	4.011	349	20	2.4	MRD12	1842	4.8	13.9	17.00	1.2685
	4	3.917	357	19	>3.5	MRD22	1950	7.9	17.0	17.00	2.6598
	4.5	4.753	295	23	1.5	MRD02	780	3.0	12.1	17.00	0.4776
	4.5	4.700	298	23	2.1	MRD12	1910	4.8	13.9	17.00	1.3450
	4.5	4.554	307	22	>3.5	MRD22	2080	7.9	17.0	17.00	2.4080



Selezione Motoriduttore - Geared Motor Selection - Getriebemotorauswahl

MRD - 1400 rpm

P ₁ [kW]	i _n	i _r	N ₂ [rpm]	M ₂ [Nm]	FS	Tipo - Size - Größe	F _{r2} [N]	MRD [kg]	FRD [kg]	J _m × 10 ⁻⁴	J ₁ × 10 ⁻⁴
0.75	5	5.276	265	26	1.5	MRD02	810	3.0	12.1	17.00	0.4698
	5	5.073	276	25	2.0	MRD12	1958	4.8	13.9	17.00	1.1726
	5	5.013	279	25	>3.5	MRD22	2210	7.9	17.0	17.00	2.3343
	5.6	5.726	244	28	1.8	MRD12	1950	4.8	13.9	17.00	1.2548
	5.6	5.747	244	28	1.8	MRD02	830	3.0	12.1	17.00	0.4955
	5.6	5.609	250	28	>3.5	MRD22	2290	7.9	17.0	17.00	2.7080
	6.3	6.253	224	31	1.6	MRD02	840	3.0	12.1	17.00	0.5407
	6.3	6.686	209	33	2.6	MRD12	1940	4.8	13.9	17.00	1.3350
	6.3	6.717	208	33	>3.5	MRD22	2410	7.9	17.0	17.00	2.9155
	7.1	7.333	191	36	1.5	MRD02	850	3.0	12.1	17.00	0.5139
	7.1	7.161	196	35	1.5	MRD12	1930	4.8	13.9	17.00	1.2885
	7.1	7.115	197	35	2.8	MRD22	2480	7.9	17.0	17.00	2.8273
	7.1	7.484	187	37	>3.5	MRD32	4900	13.5	22.6	17.00	4.9591
	8	7.979	175	39	1.2	MRD02	860	3.0	12.1	17.00	0.4967
	8	8.129	172	40	2.2	MRD12	1910	4.8	13.9	17.00	1.2435
	8	8.267	169	41	>3.5	MRD22	2600	7.9	17.0	17.00	2.5853
	9	9.315	150	46	1.0	MRD12	1890	4.8	13.9	17.00	1.1992
	9	9.524	147	47	1.2	MRD02	860	3.0	12.1	17.00	0.4703
	9	9.203	152	45	1.8	MRD22	2650	7.9	17.0	17.00	2.4240
	10	10.362	135	51	1.0	MRD02	860	3.0	12.1	17.00	0.4647
	10	10.581	132	52	1.7	MRD12	1850	4.8	13.9	17.00	1.1569
	10	10.333	135	51	3.5	MRD22	2730	7.9	17.0	17.00	2.3289
	11.2	11.806	119	58	0.9	MRD02	850	3.0	12.1	17.00	0.4508
	11.2	11.859	118	58	1.0	MRD22	2800	7.9	17.0	17.00	2.2104
	11.2	11.049	127	54	>3.5	MRD42	6400	20.0	29.1	17.00	5.8629
	12.5	12.844	109	63	0.8	MRD02	850	3.0	12.1	17.00	0.4472
	12.5	13.384	105	66	1.4	MRD12	1750	4.8	13.9	17.00	1.1028
	12.5	13.227	106	65	2.8	MRD22	2970	7.9	17.0	17.00	2.1227
	16	16.309	86	80	1.1	MRD12	1620	4.8	13.9	17.00	1.0704
	16	16.290	86	80	2.3	MRD22	3120	7.9	17.0	17.00	2.0125
	16	16.451	85	81	>3.5	MRD32	6760	13.5	22.6	17.00	3.4440
	20	20.391	69	100	0.9	MRD12	1360	4.8	13.9	17.00	1.0429
	20	20.667	68	102	1.8	MRD22	3170	7.9	17.0	17.00	1.9223
	20	19.362	72	95	>3.5	MRD32	7100	13.5	22.6	17.00	3.0791
	20	19.643	71	97	>3.5	MRD42	9280	20.0	29.1	17.00	4.8307
	25	26.729	52	131	1.4	MRD22	2980	7.9	17.0	17.00	1.8534
	25	25.255	55	124	3.2	MRD32	7550	13.5	22.6	17.00	2.5126
	25	24.478	57	120	>3.5	MRD42	9300	20.0	29.1	17.00	4.6177
	31.5	31.477	44	155	1.2	MRD22	2790	7.9	17.0	17.00	1.8236
	31.5	33.214	42	163	2.2	MRD32	7350	13.5	22.6	17.00	2.3727
	31.5	29.643	47	146	>3.5	MRD42	9460	20.0	29.1	17.00	4.4870
	40	40.759	34	196	1.0	MRD23	1750	8.5	17.6	17.00	1.7099
	40	38.571	36	190	1.4	MRD32	6800	13.5	22.6	17.00	2.4830
	40	41.538	34	204	1.9	MRD42	10480	20.0	29.1	17.00	4.5875
	40	38.063	37	183	2.2	MRD33	5000	14.5	23.6	17.00	2.5282
	40	41.875	33	202	3.0	MRD43	9900	21.5	30.6	17.00	4.4941
	40	39.333	36	189	>3.5	MRD53	7600	52.0	61.1	17.00	10.5260
	50	52.172	27	251	0.8	MRD23	1500	8.5	17.6	17.00	2.5308
	50	50.727	28	249	1.1	MRD32	5950	13.5	22.6	17.00	2.3555
	50	50.303	28	247	1.6	MRD42	9500	20.0	29.1	17.00	4.3886

Selezione Motoriduttore - Geared Motor Selection - Getriebemotorauswahl
RD
MRD - 1400 rpm

P ₁ [kW]	i _n	i _r	N ₂ [rpm]	M ₂ [Nm]	FS	Tipo - Size - Größe	F _{r2} [N]	MRD [kg]	FRD [kg]	J _m × 10 ⁻⁴	J ₁ × 10 ⁻⁴
0.75	50	48.772	29	235	1.7	MRD33	6900	14.5	23.6	17.00	4.8058
	50	51.084	27	246	2.5	MRD43	9800	21.5	30.6	17.00	6.8717
	50	47.984	29	231	>3.5	MRD53	7800	52.0	61.1	17.00	13.8540
	63	63.333	22	311	0.9	MRD32	5000	13.5	22.6	17.00	2.2850
	63	62.963	22	309	1.3	MRD42	8500	20.0	29.1	17.00	4.2181
	63	64.836	22	312	1.3	MRD33	5900	14.5	23.6	17.00	4.8220
	63	63.747	22	307	2.0	MRD43	9700	21.5	30.6	17.00	7.2550
	63	59.878	23	288	>3.5	MRD53	7800	52.0	61.1	17.00	14.3910
	80	76.310	18	367	1.1	MRD33	4900	14.5	23.6	17.00	4.9660
	80	82.254	17	396	1.6	MRD43	9200	21.5	30.6	17.00	7.0373
	80	77.262	18	372	3.2	MRD53	7900	52.0	61.1	17.00	14.0870
	80	81.289	17	391	>3.5	MRD63	11900	70.0	79.1	17.00	36.2230
	90	95.524	15	460	>3.5	MRD63	11900	70.0	79.1	17.00	35.6020
	100	99.535	14	479	0.9	MRD33	3500	14.5	23.6	17.00	5.1610
	100	102.502	14	494	1.3	MRD43	8100	21.5	30.6	17.00	6.6923
	100	96.280	15	464	2.6	MRD53	7900	52.0	61.1	17.00	13.6030
	100	104.082	13	501	>3.5	MRD63	11900	70.0	79.1	17.00	34.9800
	112	116.595	12	561	2.1	MRD53	8050	52.0	61.1	17.00	13.5850
	125	124.129	11	598	1.1	MRD43	6000	21.5	30.6	17.00	6.6730
	125	129.800	11	625	1.9	MRD53	8100	52.0	61.1	17.00	13.5760
	125	125.867	11	606	3.5	MRD63	12000	70.0	79.1	17.00	34.9100
	140	145.939	9.6	703	1.7	MRD53	8050	52.0	61.1	17.00	13.4760
	160	160.689	8.7	774	0.8	MRD43	5000	21.5	30.6	17.00	8.8326
	160	157.143	8.9	757	1.6	MRD53	8200	52.0	61.1	17.00	16.6000
	160	157.333	8.9	758	2.8	MRD63	12300	70.0	79.1	17.00	42.6850
	180	171.533	8.2	826	2.5	MRD63	12500	70.0	79.1	17.00	42.3380
	200	195.824	7.1	943	1.3	MRD53	8400	52.0	61.1	17.00	16.3280
	200	201.571	6.9	971	2.2	MRD63	12600	70.0	79.1	17.00	41.9870
	225	237.143	5.9	1142	1.1	MRD53	8200	52.0	61.1	17.00	16.1000
	225	219.631	6.4	1057	2.0	MRD63	12800	70.0	79.1	17.00	41.3720
250	264.000	5.3	1271	0.9	MRD53	8700	52.0	61.1	17.00	15.8540	
250	265.600	5.3	1279	1.6	MRD63	13000	70.0	79.1	17.00	40.7660	
280	296.825	4.7	1429	0.8	MRD53	8800	52.0	61.1	17.00	15.8560	
315	332.000	4.2	1599	1.3	MRD63	13500	70.0	79.1	17.00	40.7740	
355	373.333	3.8	1798	1.2	MRD63	15700	70.0	79.1	17.00	40.7990	
450	448.000	3.1	2157	0.8	MRD63	16800	70.0	79.1	17.00	40.7660	
1.1	2.25	2.348	596	17	2.4	MRD12	1430	4.8	16.5	33.00	1.7275
	2.25	2.313	605	17	>3.5	MRD22	1260	7.9	19.6	33.00	4.1128
	2.5	2.534	552	18	2.2	MRD12	1569	4.8	16.5	33.00	1.4856
	2.5	2.548	549	18	>3.5	MRD22	1390	7.9	19.6	33.00	3.4569
	2.8	2.855	490	21	2.1	MRD12	1620	4.8	16.5	33.00	0.1457
	2.8	2.846	492	21	>3.5	MRD22	1510	7.9	19.6	33.00	3.1032
	3.15	3.081	454	22	1.9	MRD12	1650	4.8	16.5	33.00	1.3036
	3.15	3.133	447	23	>3.5	MRD22	1700	7.9	19.6	33.00	2.8995
	3.55	3.716	377	27	1.7	MRD12	1710	4.8	16.5	33.00	1.1709
	3.55	3.558	393	26	3.5	MRD22	1760	7.9	19.6	33.00	2.6305
	4	4.011	349	29	1.6	MRD12	1761	4.8	16.5	33.00	1.1395
	4	3.917	357	28	3.3	MRD22	1890	7.9	19.6	33.00	2.4858
	4.5	4.700	298	34	1.4	MRD12	1810	4.8	16.5	33.00	1.2026
	4.5	4.554	307	33	3.0	MRD22	2020	7.9	19.6	33.00	2.2505



Selezione Motoriduttore - Geared Motor Selection - Getriebemotorauswahl

MRD - 1400 rpm

P ₁ [kW]	i _n	i _r	N ₂ [rpm]	M ₂ [Nm]	FS	Tipo - Size - Größe	F _{r2} [N]	MRD [kg]	FRD [kg]	J _m × 10 ⁻⁴	J ₁ × 10 ⁻⁴
1.1	5	5.073	276	37	1.4	MRD12	1855	4.8	16.5	33.00	1.0436
	5	5.013	279	36	2.7	MRD22	2160	7.9	19.6	33.00	2.1816
	5	5.331	263	38	>3.5	MRD32	3950	13.5	25.2	33.00	3.7739
	5.6	5.726	244	41	1.2	MRD12	1900	4.8	16.5	33.00	1.1271
	5.6	5.609	250	40	2.5	MRD22	2220	7.9	19.6	33.00	2.5308
	6.3	6.686	209	48	1.8	MRD12	1870	4.8	16.5	33.00	1.2060
	6.3	6.717	208	48	>3.5	MRD22	2330	7.9	19.6	33.00	2.7248
	7.1	7.161	196	52	1.0	MRD12	1750	4.8	16.5	33.00	1.1550
	7.1	7.115	197	51	1.9	MRD22	2410	7.9	19.6	33.00	2.6423
	7.1	7.484	187	54	>3.5	MRD32	4580	13.5	25.2	33.00	4.6784
	8	8.129	172	59	1.5	MRD12	1800	4.8	16.5	33.00	1.1144
	8	8.267	169	60	3.0	MRD22	2510	7.9	19.6	33.00	2.4162
	9	9.203	152	66	1.3	MRD22	2570	7.9	19.6	33.00	2.2654
	9	9.124	153	66	>3.5	MRD42	5220	20.0	31.7	33.00	11.7090
	10	10.581	132	76	1.2	MRD12	1660	4.8	16.5	33.00	1.0278
	10	10.333	135	74	2.4	MRD22	2650	7.9	19.6	33.00	2.1765
	10	9.658	145	70	>3.5	MRD32	5690	13.5	25.2	33.00	3.7274
	11.2	11.049	127	80	2.7	MRD42	5800	20.0	31.7	33.00	10.6328
	11.2	11.310	124	81	>3.5	MRD52	6000	49.0	60.7	33.00	13.8310
	12.5	13.384	105	96	0.9	MRD12	1420	4.8	16.5	33.00	0.9738
	12.5	13.227	106	95	1.9	MRD22	2790	7.9	19.6	33.00	1.9928
	12.5	12.375	113	89	>3.5	MRD32	6000	13.5	25.2	33.00	3.1944
	16	16.309	86	118	0.8	MRD12	1030	4.8	16.5	33.00	0.9414
	16	16.290	86	117	1.6	MRD22	2900	7.9	19.6	33.00	1.8826
	16	16.451	85	119	3.3	MRD32	6290	13.5	25.2	33.00	3.2491
	16	15.223	92	110	>3.5	MRD42	8270	20.0	31.7	33.00	9.3809
	20	20.667	68	149	1.2	MRD22	2850	7.9	19.6	33.00	1.7924
	20	19.362	72	140	2.8	MRD32	6560	13.5	25.2	33.00	2.9048
	20	19.643	71	142	>3.5	MRD42	8410	20.0	31.7	33.00	8.7608
	25	26.729	52	193	1.0	MRD22	2380	7.9	19.6	33.00	1.7234
	25	25.255	55	182	2.2	MRD32	7020	13.5	25.2	33.00	2.3847
	25	24.478	57	176	3.3	MRD42	8820	20.0	31.7	33.00	8.3681
	25	25.989	54	187	>3.5	MRD52	9000	49.0	60.7	33.00	10.9630
	31.5	31.477	44	227	0.8	MRD22	1820	7.9	19.6	33.00	1.6937
	31.5	33.214	42	239	1.5	MRD32	6900	13.5	25.2	33.00	2.2448
	31.5	29.643	47	214	2.7	MRD42	9290	20.0	31.7	33.00	8.0069
	31.5	31.429	45	226	>3.5	MRD52	9100	49.0	60.7	33.00	10.6470
	40	38.571	36	278	1.0	MRD32	6470	13.5	25.2	33.00	2.3551
	40	41.538	34	299	1.3	MRD42	9860	20.0	31.7	33.00	7.9357
	40	38.063	37	269	1.5	MRD33	3800	14.5	26.2	33.00	2.3981
	40	41.875	33	296	2.1	MRD43	9700	21.5	33.2	33.00	7.8832
	40	40.476	35	292	2.6	MRD52	10500	49.0	60.7	33.00	10.8580
	40	39.333	36	278	>3.5	MRD53	7600	52.0	63.7	33.00	10.5260
	40	40.500	35	292	>3.5	MRD62	15700	62.0	73.7	33.00	27.9190
	50	50.727	28	366	0.7	MRD32	6600	13.5	25.2	33.00	2.2276
	50	50.303	28	362	1.1	MRD42	9310	20.0	31.7	33.00	7.7368
	50	48.772	29	344	1.2	MRD33	5400	14.5	26.2	33.00	4.8359
	50	51.084	27	361	1.7	MRD43	9500	21.5	33.2	33.00	10.2610
	50	53.333	26	384	2.0	MRD52	11200	49.0	60.7	33.00	10.5790
	50	47.984	29	339	3.4	MRD53	7800	52.0	63.7	33.00	13.8540

Selezione Motoriduttore - Geared Motor Selection - Getriebemotorauswahl
MRD - 1400 rpm

P ₁ [kW]	i _n	i _r	N ₂ [rpm]	M ₂ [Nm]	FS	Tipo - Size - Größe	F _{r2} [N]	MRD [kg]	FRD [kg]	J _m × 10 ⁻⁴	J ₁ × 10 ⁻⁴
1.1	50	49.800	28	359	>3.5	MRD62	16800	62.0	73.7	33.00	27.2030
	50	48.948	29	346	>3.5	MRD63	11700	70.0	81.7	33.00	35.6250
	63	62.963	22	454	0.9	MRD42	8200	20.0	31.7	33.00	7.5664
	63	64.836	22	458	0.9	MRD33	4000	14.5	26.2	33.00	5.2297
	63	63.747	22	450	1.4	MRD43	8700	21.5	33.2	33.00	10.6440
	63	66.667	21	480	1.6	MRD52	12000	49.0	60.7	33.00	10.3400
	63	59.878	23	423	2.8	MRD53	7800	52.0	63.7	33.00	14.3910
	63	56.000	25	404	3.5	MRD62	18000	62.0	73.7	33.00	26.5900
	63	61.884	23	437	>3.5	MRD63	11700	70.0	81.7	33.00	37.0040
	80	76.310	18	539	0.8	MRD33	3000	14.5	26.2	33.00	5.0309
	80	82.254	17	581	1.1	MRD43	6700	21.5	33.2	33.00	10.4260
	80	77.262	18	546	2.2	MRD53	7900	52.0	63.7	33.00	14.0870
	80	81.289	17	574	>3.5	MRD63	11900	70.0	81.7	33.00	36.2230
	90	95.524	15	675	3.1	MRD63	11900	70.0	81.7	33.00	35.6020
	100	102.502	14	724	0.9	MRD43	5500	21.5	33.2	33.00	10.0810
	100	96.280	15	680	1.8	MRD53	7900	52.0	63.7	33.00	13.6030
	100	104.082	13	735	2.9	MRD63	11900	70.0	81.7	33.00	34.9800
	112	116.595	12	823	1.5	MRD53	8050	52.0	63.7	33.00	13.5850
	125	124.129	11	877	0.7	MRD43	5620	21.5	33.2	33.00	10.0851
	125	129.800	11	917	1.3	MRD53	8100	52.0	63.7	33.00	13.5760
	125	125.867	11	889	2.4	MRD63	12000	70.0	81.7	33.00	34.9100
	140	145.939	9.6	1031	1.2	MRD53	8050	52.0	63.7	33.00	13.4760
	160	157.143	8.9	1110	1.1	MRD53	8200	52.0	63.7	33.00	16.6000
	160	157.333	8.9	1111	1.9	MRD63	12300	70.0	81.7	33.00	42.6850
	180	171.533	8.2	1211	1.7	MRD63	12500	70.0	81.7	33.00	42.3380
	200	195.824	7.1	1383	0.9	MRD53	8400	52.0	63.7	33.00	16.3280
	200	201.571	6.9	1423	1.5	MRD63	12600	70.0	81.7	33.00	41.9870
225	219.631	6.4	1551	1.4	MRD63	12800	70.0	81.7	33.00	41.3720	
250	265.600	5.3	1876	1.1	MRD63	13000	70.0	81.7	33.00	40.7660	
315	332.000	4.2	2345	0.9	MRD63	13500	70.0	81.7	33.00	40.7740	
355	373.333	3.8	2636	0.8	MRD63	15700	70.0	81.7	33.00	40.7990	
1.5	2.25	2.348	596	23	1.7	MRD12	1430	4.8	19.2	40.00	1.7275
	2.25	2.313	605	23	3.5	MRD22	1770	7.9	22.3	40.00	4.1128
	2.5	2.534	552	25	1.6	MRD12	1570	4.8	19.2	40.00	1.4832
	2.5	2.548	549	25	3.2	MRD22	1950	7.9	22.3	40.00	3.4569
	2.8	2.855	490	28	1.5	MRD12	1620	4.8	19.2	40.00	0.1457
	2.8	2.846	492	28	3.0	MRD22	1870	7.9	22.3	40.00	3.1032
	3.15	3.081	454	30	1.4	MRD12	1650	4.8	19.2	40.00	1.2412
	3.15	3.133	447	31	2.8	MRD22	1840	7.9	22.3	40.00	2.8995
	3.15	3.324	421	33	>3.5	MRD32	3190	13.5	27.9	40.00	5.9052
	3.55	3.716	377	37	1.3	MRD12	1710	4.8	19.2	40.00	1.1709
	3.55	3.558	393	35	2.6	MRD22	1860	7.9	22.3	40.00	2.6305
	3.55	3.733	375	37	>3.5	MRD32	3190	13.5	27.9	40.00	5.4374
	4	4.011	349	39	1.2	MRD12	1760	4.8	19.2	40.00	1.0229
	4	3.917	357	38	2.4	MRD22	1950	7.9	22.3	40.00	2.4858
	4	4.160	337	41	>3.5	MRD32	3340	13.5	27.9	40.00	4.6789
	4.5	4.700	298	46	1.1	MRD12	1810	4.8	19.2	40.00	1.2026
	4.5	4.554	307	45	2.2	MRD22	2020	7.9	22.3	40.00	2.2505
	4.5	4.783	293	47	>3.5	MRD32	3480	13.5	27.9	40.00	4.2591
5	5.073	276	50	1.0	MRD12	1860	4.8	19.2	40.00	0.8954	



Selezione Motoriduttore - Geared Motor Selection - Getriebemotorauswahl

MRD - 1400 rpm

P ₁ [kW]	i _n	i _r	N ₂ [rpm]	M ₂ [Nm]	FS	Tipo - Size - Größe	F _{r2} [N]	MRD [kg]	FRD [kg]	J _m × 10 ⁻⁴	J ₁ × 10 ⁻⁴
1.5	5	5.013	279	49	2.0	MRD22	2060	7.9	22.3	40.00	2.1816
	5	5.331	263	52	>3.5	MRD32	3630	13.5	27.9	40.00	3.7739
	5.6	5.726	244	56	0.9	MRD12	1900	4.8	19.2	40.00	1.1271
	5.6	5.609	250	55	1.9	MRD22	2150	7.9	22.3	40.00	2.5308
	6.3	6.686	209	66	1.3	MRD12	1870	4.8	19.2	40.00	1.1115
	6.3	6.717	208	66	2.7	MRD22	2280	7.9	22.3	40.00	2.7248
	6.3	6.261	224	62	>3.5	MRD32	3920	13.5	27.9	40.00	5.2968
	7.1	7.161	196	70	0.8	MRD12	1750	4.8	19.2	40.00	1.1550
	7.1	7.115	197	70	1.4	MRD22	2310	7.9	22.3	40.00	2.6423
	7.1	7.484	187	74	3.0	MRD32	4210	13.5	27.9	40.00	4.6784
	7.1	7.321	191	72	>3.5	MRD42	4490	20.0	34.4	40.00	12.9314
	8	8.129	172	80	1.1	MRD12	1800	4.8	19.2	40.00	0.9897
	8	8.267	169	81	2.2	MRD22	2380	7.9	22.3	40.00	2.4162
	8	7.717	181	76	>3.5	MRD32	4500	13.5	27.9	40.00	4.4149
	9	9.203	152	90	0.9	MRD22	2430	7.9	22.3	40.00	2.2654
	9	9.124	153	90	3.1	MRD42	4900	20.0	34.4	40.00	11.3807
	9	9.353	150	92	>3.5	MRD52	5300	49.0	63.4	40.00	15.1540
	10	10.581	132	104	0.9	MRD12	1650	4.8	19.2	40.00	0.8745
	10	10.333	135	102	1.8	MRD22	2490	7.9	22.3	40.00	2.1765
	10	9.658	145	95	>3.5	MRD32	5220	13.5	27.9	40.00	3.7274
	10	10.000	140	98	>3.5	MRD42	5030	20.0	34.4	40.00	10.7442
	11.2	11.049	127	109	2.0	MRD42	5440	20.0	34.4	40.00	10.3347
	11.2	11.310	124	111	>3.5	MRD52	6000	49.0	63.4	40.00	13.8310
	12.5	13.227	106	130	1.4	MRD22	2580	7.9	22.3	40.00	1.9928
	12.5	12.375	113	122	3.1	MRD32	5500	13.5	27.9	40.00	3.1944
	12.5	12.199	115	120	>3.5	MRD42	6260	20.0	34.4	40.00	9.8529
	16	16.290	86	160	1.1	MRD22	2650	7.9	22.3	40.00	1.8826
	16	16.451	85	162	2.4	MRD32	6080	13.5	27.9	40.00	3.2491
	16	15.223	92	150	>3.5	MRD42	7750	20.0	34.4	40.00	9.1179
	20	20.667	68	203	0.9	MRD22	2230	7.9	22.3	40.00	1.7924
	20	19.362	72	190	2.0	MRD32	6310	13.5	27.9	40.00	2.9048
	20	19.643	71	193	3.0	MRD42	8050	20.0	34.4	40.00	8.3681
	20	20.298	69	199	>3.5	MRD52	8700	49.0	63.4	40.00	11.4630
	25	25.255	55	248	1.6	MRD32	6705	13.5	27.9	40.00	2.3847
	25	24.478	57	241	2.4	MRD42	8510	20.0	34.4	40.00	8.3681
	25	25.989	54	255	>3.5	MRD52	9000	49.0	63.4	40.00	10.9630
	31.5	33.214	42	326	1.1	MRD32	5700	13.5	27.9	40.00	2.2448
	31.5	29.643	47	291	2.0	MRD42	8920	20.0	34.4	40.00	8.0069
	31.5	31.429	45	309	>3.5	MRD52	9100	49.0	63.4	40.00	10.6470
	40	41.538	34	408	0.9	MRD42	8830	20.0	34.4	40.00	7.9357
	40	38.063	37	367	1.1	MRD33	3000	14.5	28.9	40.00	2.3981
	40	41.875	33	403	1.5	MRD43	9200	21.5	35.9	40.00	7.8832
	40	40.476	35	398	1.9	MRD52	10500	49.0	63.4	40.00	10.8580
	40	39.333	36	379	3.0	MRD53	7600	52.0	66.4	40.00	10.5260
	40	40.500	35	398	3.5	MRD62	15700	62.0	76.4	40.00	27.9190
	40	39.708	35	382	>3.5	MRD63	11400	70.0	84.4	40.00	27.0660
	50	50.303	28	494	0.8	MRD42	7850	20.0	34.4	40.00	7.7368
	50	48.772	29	470	0.9	MRD33	4500	14.5	28.9	40.00	4.8359
	50	51.084	27	492	1.3	MRD43	8100	21.5	35.9	40.00	10.2610
	50	53.333	26	524	1.4	MRD52	11200	49.0	63.4	40.00	10.5790

Selezione Motoriduttore - Geared Motor Selection - Getriebemotorauswahl
MRD - 1400 rpm

P ₁ [kW]	i _n	i _r	N ₂ [rpm]	M ₂ [Nm]	FS	Tipo - Size - Größe	F _{r2} [N]	MRD [kg]	FRD [kg]	J _m × 10 ⁻⁴	J ₁ × 10 ⁻⁴
1.5	50	47.984	29	462	2.5	MRD53	7800	52.0	66.4	40.00	13.8540
	50	49.800	28	489	2.9	MRD62	16800	62.0	76.4	40.00	27.2030
	50	48.948	29	471	>3.5	MRD63	11700	70.0	84.4	40.00	35.6250
	63	63.747	22	614	1.0	MRD43	6000	21.5	35.9	40.00	10.6440
	63	66.667	21	655	1.2	MRD52	12000	49.0	63.4	40.00	10.3400
	63	59.878	23	577	2.0	MRD53	7800	52.0	66.4	40.00	14.3910
	63	56.000	25	550	2.6	MRD62	18000	62.0	76.4	40.00	26.5900
	63	61.884	23	596	3.4	MRD63	11700	70.0	84.4	40.00	37.0040
	80	82.254	17	792	0.8	MRD43	6100	21.5	35.9	40.00	10.4260
	80	77.262	18	744	1.6	MRD53	7900	52.0	66.4	40.00	14.0870
	80	81.289	17	783	2.6	MRD63	11900	70.0	84.4	40.00	36.2230
	90	95.524	15	920	2.3	MRD63	11900	70.0	84.4	40.00	35.6020
	100	96.280	15	927	1.3	MRD53	7900	52.0	66.4	40.00	13.6030
	100	104.082	13	1002	2.1	MRD63	11900	70.0	84.4	40.00	34.9800
	112	116.595	12	1123	1.1	MRD53	8050	52.0	66.4	40.00	13.5850
	125	129.800	11	1250	1.0	MRD53	8100	52.0	66.4	40.00	13.5760
	125	125.867	11	1212	1.7	MRD63	12000	70.0	84.4	40.00	34.9100
	140	145.939	9.6	1405	0.9	MRD53	8050	52.0	66.4	40.00	13.4760
	160	157.143	8.9	1513	0.8	MRD53	8200	52.0	66.4	40.00	16.6000
	160	157.333	8.9	1515	1.4	MRD63	12300	70.0	84.4	40.00	42.6850
180	171.533	8.2	1652	1.3	MRD63	12500	70.0	84.4	40.00	42.3380	
200	201.571	6.9	1941	1.1	MRD63	12600	70.0	84.4	40.00	41.9870	
225	219.631	6.4	2115	1.0	MRD63	12800	70.0	84.4	40.00	41.3720	
250	265.600	5.3	2558	0.8	MRD63	13000	70.0	84.4	40.00	40.7660	
2.2	2.25	2.313	605	33	2.4	MRD22	1520	7.9	27.1	75.00	4.6063
	2.25	2.420	579	35	>3.5	MRD32	3500	13.5	32.7	75.00	9.3605
	2.5	2.548	549	37	2.2	MRD22	1670	7.9	27.1	75.00	3.8842
	2.5	2.697	519	39	>3.5	MRD32	3680	13.5	32.7	75.00	8.3167
	2.8	2.846	492	41	2.1	MRD22	1700	7.9	27.1	75.00	3.5687
	2.8	2.983	469	43	>3.5	MRD32	3680	13.5	32.7	75.00	7.1920
	3.15	3.133	447	45	1.9	MRD22	1740	7.9	27.1	75.00	3.3268
	3.15	3.324	421	48	>3.5	MRD32	3850	13.5	32.7	75.00	6.4957
	3.55	3.558	393	51	1.8	MRD22	1750	7.9	27.1	75.00	3.0777
	3.55	3.733	375	54	>3.5	MRD32	3780	13.5	32.7	75.00	5.9811
	4	3.917	357	56	1.6	MRD22	1820	7.9	27.1	75.00	2.9131
	4	4.160	337	60	3.5	MRD32	3960	13.5	32.7	75.00	5.1468
	4.5	4.554	307	66	1.5	MRD22	1860	7.9	27.1	75.00	2.7006
	4.5	4.783	293	69	3.1	MRD32	4130	13.5	32.7	75.00	4.6850
	4.5	4.547	308	66	>3.5	MRD42	4140	20.0	39.2	75.00	12.1150
	5	5.013	279	72	1.4	MRD22	1890	7.9	27.1	75.00	2.6089
	5	5.331	263	77	2.9	MRD32	4250	13.5	32.7	75.00	4.2003
	5	4.830	290	70	>3.5	MRD42	4440	20.0	39.2	75.00	10.8080
	5.6	5.609	250	81	1.3	MRD22	1970	7.9	27.1	75.00	2.9357
	5.6	5.674	247	82	>3.5	MRD42	4440	20.0	39.2	75.00	12.4830
	6.3	6.717	208	97	1.8	MRD22	2100	7.9	27.1	75.00	3.1521
	6.3	6.261	224	90	>3.5	MRD32	4460	13.5	32.7	75.00	5.8794
	7.1	7.115	197	103	1.0	MRD22	2120	7.9	27.1	75.00	3.0915
7.1	7.484	187	108	2.0	MRD32	4640	13.5	32.7	75.00	5.1930	
7.1	7.321	191	106	3.0	MRD42	4880	20.0	39.2	75.00	12.4340	
7.1	7.305	192	105	>3.5	MRD52	4800	49.0	68.2	75.00	18.3510	



Selezione Motoriduttore - Geared Motor Selection - Getriebemotorauswahl

MRD - 1400 rpm

P ₁ [kW]	i _n	i _r	N ₂ [rpm]	M ₂ [Nm]	FS	Tipo - Size - Größe	F _{r2} [N]	MRD [kg]	FRD [kg]	J _m × 10 ⁻⁴	J ₁ × 10 ⁻⁴
2.2	8	8.267	169	119	1.5	MRD22	2160	7.9	27.1	75.00	2.8435
	8	7.717	181	111	3.4	MRD32	4800	13.5	32.7	75.00	4.8413
	8	7.857	178	113	>3.5	MRD42	5180	20.0	39.2	75.00	11.7590
	9	9.124	153	131	2.1	MRD42	5330	20.0	39.2	75.00	10.9430
	9	9.353	150	135	>3.5	MRD52	5300	49.0	68.2	75.00	15.1540
	10	10.333	135	149	1.2	MRD22	2200	7.9	27.1	75.00	2.6037
	10	9.658	145	139	2.7	MRD32	5050	13.5	32.7	75.00	4.1539
	10	10.000	140	144	>3.5	MRD42	5480	20.0	39.2	75.00	10.3310
	11.2	11.049	127	159	1.3	MRD42	5920	20.0	39.2	75.00	9.9372
	11.2	11.310	124	163	2.5	MRD52	6000	49.0	68.2	75.00	13.8310
	11.2	11.734	119	169	>3.5	MRD62	9000	62.0	81.2	75.00	35.1550
	12.5	13.227	106	191	0.9	MRD22	2220	7.9	27.1	75.00	2.4201
	12.5	12.375	113	178	2.1	MRD32	5360	13.5	32.7	75.00	3.6208
	12.5	12.199	115	176	3.2	MRD42	6800	20.0	39.2	75.00	9.4739
	16	16.290	86	235	0.8	MRD22	1650	7.9	27.1	75.00	2.3099
	16	16.451	85	237	1.6	MRD32	5710	13.5	32.7	75.00	3.6755
	16	15.223	92	219	2.6	MRD42	7180	20.0	39.2	75.00	8.7672
	16	15.452	91	223	>3.5	MRD52	8500	49.0	68.2	75.00	12.2740
	20	19.362	72	279	1.4	MRD32	5890	13.5	32.7	75.00	3.3312
	20	19.643	71	283	2.0	MRD42	7620	20.0	39.2	75.00	8.1877
	20	20.298	69	293	>3.5	MRD52	8700	49.0	68.2	75.00	11.4630
	25	25.255	55	364	1.1	MRD32	5000	13.5	32.7	75.00	2.8112
	25	24.478	57	353	1.7	MRD42	7990	20.0	39.2	75.00	7.8266
	25	25.989	54	375	3.0	MRD52	9000	49.0	68.2	75.00	10.9630
	25	24.615	57	355	>3.5	MRD62	13500	62.0	81.2	75.00	28.1880
	31.5	33.214	42	479	0.7	MRD32	5220	13.5	32.7	75.00	2.6489
	31.5	29.643	47	427	1.4	MRD42	8290	20.0	39.2	75.00	7.6050
	31.5	31.429	45	453	2.5	MRD52	9100	49.0	68.2	75.00	10.6470
	31.5	33.200	42	478	>3.5	MRD62	13700	62.0	81.2	75.00	27.3780
	40	38.063	37	538	0.8	MRD33	4400	14.5	33.7	75.00	2.3849
	40	41.875	33	591	1.0	MRD43	6800	21.5	40.7	75.00	7.6977
	40	40.476	35	583	1.3	MRD52	10500	49.0	68.2	75.00	10.8580
	40	39.333	36	556	2.1	MRD53	7600	52.0	71.2	75.00	10.5260
	40	40.500	35	584	2.4	MRD62	15700	62.0	81.2	75.00	27.9190
	40	39.708	35	561	>3.5	MRD63	11400	70.0	89.2	75.00	27.0660
	50	51.084	27	721	0.9	MRD43	5500	21.5	40.7	75.00	10.0753
	50	53.333	26	769	1.0	MRD52	11200	49.0	68.2	75.00	10.5790
	50	47.984	29	678	1.7	MRD53	7800	52.0	71.2	75.00	13.8540
	50	49.800	28	718	2.0	MRD62	16800	62.0	81.2	75.00	27.2030
	50	48.948	29	691	2.9	MRD63	11700	70.0	89.2	75.00	35.6250
	63	66.667	21	961	0.8	MRD52	12000	49.0	68.2	75.00	10.3400
	63	59.878	23	846	1.4	MRD53	7800	52.0	71.2	75.00	14.3910
	63	56.000	25	807	1.7	MRD62	18000	62.0	81.2	75.00	26.5900
	63	61.884	23	874	2.3	MRD63	11700	70.0	89.2	75.00	37.0040
	80	77.262	18	1091	1.1	MRD53	7900	52.0	71.2	75.00	14.0870
	80	81.289	17	1148	1.8	MRD63	11900	70.0	89.2	75.00	36.2230
	90	95.524	15	1349	1.5	MRD63	11900	70.0	89.2	75.00	35.6020
	100	96.280	15	1360	0.9	MRD53	7900	52.0	71.2	75.00	13.6030
	100	104.082	13	1470	1.4	MRD63	11900	70.0	89.2	75.00	34.9800
	112	116.595	12	1647	0.7	MRD53	8050	52.0	71.2	75.00	13.5850

Selezione Motoriduttore - Geared Motor Selection - Getriebemotorauswahl
MRD - 1400 rpm

P ₁ [kW]	i _n	i _r	N ₂ [rpm]	M ₂ [Nm]	FS	Tipo - Size - Größe	F _{r2} [N]	MRD [kg]	FRD [kg]	J _m × 10 ⁻⁴	J ₁ × 10 ⁻⁴
2.2	125	125.867	11	1778	1.2	MRD63	12000	70.0	89.2	75.00	34.9100
	160	157.333	8.9	2222	0.9	MRD63	12300	70.0	89.2	75.00	42.6850
	180	171.533	8.2	2423	0.9	MRD63	12500	70.0	89.2	75.00	42.3380
	200	201.571	6.9	2847	0.7	MRD63	12600	70.0	89.2	75.00	41.9870
3	2.25	2.313	605	45	1.7	MRD22	1430	7.9	30.8	85.00	4.6063
	2.25	2.420	579	48	>3.5	MRD32	3300	13.5	36.4	85.00	10.0157
	2.5	2.548	549	50	1.6	MRD22	1570	7.9	30.8	85.00	3.8842
	2.5	2.697	519	53	3.4	MRD32	3470	13.5	36.4	85.00	8.0898
	2.8	2.846	492	56	1.5	MRD22	1570	7.9	30.8	85.00	3.5066
	2.8	2.983	469	59	3.1	MRD32	3470	13.5	36.4	85.00	6.9959
	2.8	2.929	478	58	>3.5	MRD42	4080	20.0	42.9	85.00	16.4540
	3.15	3.133	447	62	1.4	MRD22	1620	7.9	30.8	85.00	3.3268
	3.15	3.324	421	65	3.0	MRD32	3630	13.5	36.4	85.00	6.3316
	3.15	3.111	450	61	>3.5	MRD42	4250	20.0	42.9	85.00	14.9760
	3.55	3.558	393	70	1.3	MRD22	1610	7.9	30.8	85.00	3.0514
	3.55	3.733	375	73	2.7	MRD32	3650	13.5	36.4	85.00	5.8724
	3.55	3.727	376	73	>3.5	MRD42	4420	20.0	42.9	85.00	13.1450
	4	3.917	357	77	1.2	MRD22	1660	7.9	30.8	85.00	2.9131
	4	4.160	337	82	2.5	MRD32	3850	13.5	36.4	85.00	5.1053
	4	3.960	354	78	>3.5	MRD42	4590	20.0	42.9	85.00	12.3170
	4.5	4.554	307	89	1.1	MRD22	1680	7.9	30.8	85.00	2.6556
	4.5	4.783	293	94	2.2	MRD32	3960	13.5	36.4	85.00	4.6850
	4.5	4.547	308	89	>3.5	MRD42	4760	20.0	42.9	85.00	12.1150
	5	5.013	279	99	1.0	MRD22	1700	7.9	30.8	85.00	2.6089
	5	5.331	263	105	2.1	MRD32	4080	13.5	36.4	85.00	4.2003
	5	4.830	290	95	>3.5	MRD42	5100	20.0	42.9	85.00	10.8080
	5.6	5.609	250	110	0.9	MRD22	1760	7.9	30.8	85.00	2.9863
	5.6	5.674	247	112	3.2	MRD42	5100	20.0	42.9	85.00	12.4830
	6.3	6.717	208	132	1.3	MRD22	1890	7.9	30.8	85.00	3.1521
	6.3	6.261	224	123	3.0	MRD32	4360	13.5	36.4	85.00	5.7232
	6.3	6.286	223	124	>3.5	MRD42	5270	20.0	42.9	85.00	13.6360
	7.1	7.484	187	147	1.5	MRD32	4470	13.5	36.4	85.00	5.0995
	7.1	7.321	191	144	2.2	MRD42	5610	20.0	42.9	85.00	12.4340
	7.1	7.305	192	144	>3.5	MRD52	4800	49.0	71.9	85.00	18.3510
	8	8.267	169	162	1.1	MRD22	1900	7.9	30.8	85.00	2.8435
	8	7.717	181	152	2.5	MRD32	4580	13.5	36.4	85.00	4.8413
8	7.857	178	154	>3.5	MRD42	5950	20.0	42.9	85.00	11.7590	
9	9.124	153	179	1.6	MRD42	6120	20.0	42.9	85.00	10.9430	
9	9.353	150	184	2.8	MRD52	5300	49.0	71.9	85.00	15.1540	
10	10.333	135	203	0.9	MRD22	1880	7.9	30.8	85.00	2.6037	
10	9.658	145	190	2.0	MRD32	4800	13.5	36.4	85.00	4.1539	
10	10.000	140	197	2.9	MRD42	6200	20.0	42.9	85.00	10.3311	
10	9.915	141	195	>3.5	MRD52	5500	49.0	71.9	85.00	14.4630	
11.2	11.049	127	217	1.0	MRD42	6720	20.0	42.9	85.00	9.9372	
11.2	11.310	124	222	1.8	MRD52	6000	49.0	71.9	85.00	13.8310	
11.2	11.734	119	231	>3.5	MRD62	9000	62.0	84.9	85.00	35.1550	
12.5	12.375	113	243	1.6	MRD32	5040	13.5	36.4	85.00	3.6208	
12.5	12.199	115	240	2.4	MRD42	6500	20.0	42.9	85.00	9.4739	
12.5	12.222	115	240	>3.5	MRD52	6900	49.0	71.9	85.00	13.2640	
16	16.451	85	323	1.2	MRD32	5300	13.5	36.4	85.00	3.6755	



Selezione Motoriduttore - Geared Motor Selection - Getriebemotorauswahl

MRD - 1400 rpm

P ₁ [kW]	i _n	i _r	N ₂ [rpm]	M ₂ [Nm]	FS	Tipo - Size - Größe	F _{r2} [N]	MRD [kg]	FRD [kg]	J _m × 10 ⁻⁴	J ₁ × 10 ⁻⁴
3	16	15.223	92	299	1.9	MRD42	6810	20.0	42.9	85.00	8.7672
	16	15.452	91	304	>3.5	MRD52	8500	49.0	71.9	85.00	12.2740
	20	19.362	72	381	1.0	MRD32	4500	13.5	36.4	85.00	3.3312
	20	19.643	71	386	1.5	MRD42	7150	20.0	42.9	85.00	8.1877
	20	20.298	69	399	2.8	MRD52	8700	49.0	71.9	85.00	11.4630
	20	20.667	68	406	>3.5	MRD62	13000	62.0	84.9	85.00	29.4770
	25	25.255	55	496	0.8	MRD32	4000	13.5	36.4	85.00	2.8112
	25	24.478	57	481	1.2	MRD42	7400	20.0	42.9	85.00	7.8266
	25	25.989	54	511	2.2	MRD52	9000	49.0	71.9	85.00	10.9630
	25	24.615	57	484	>3.5	MRD62	13500	62.0	84.9	85.00	28.1880
	31.5	29.643	47	583	1.0	MRD42	6110	20.0	42.9	85.00	7.6050
	31.5	31.429	45	618	1.8	MRD52	9100	49.0	71.9	85.00	10.6470
	31.5	33.200	42	652	3.0	MRD62	13700	62.0	84.9	85.00	27.3780
	40	41.875	33	806	0.8	MRD43	5800	21.5	44.4	85.00	7.6977
	40	40.476	35	795	0.9	MRD52	10500	49.0	71.9	85.00	10.8580
	40	39.333	36	758	1.5	MRD53	7600	52.0	74.9	85.00	10.5260
	40	40.500	35	796	1.7	MRD62	15700	62.0	84.9	85.00	27.9190
	40	39.708	35	765	2.6	MRD63	11400	70.0	92.9	85.00	27.0660
	50	47.984	29	924	1.3	MRD53	7800	52.0	74.9	85.00	13.8540
	50	49.800	28	979	1.4	MRD62	16800	62.0	84.9	85.00	27.2030
	50	48.948	29	943	2.1	MRD63	11700	70.0	92.9	85.00	35.6250
	63	59.878	23	1153	1.0	MRD53	7800	52.0	74.9	85.00	14.3910
	63	56.000	25	1101	1.3	MRD62	18000	62.0	84.9	85.00	26.5900
	63	61.884	23	1192	1.7	MRD63	11700	70.0	92.9	85.00	37.0040
	80	77.262	18	1488	0.8	MRD53	7900	52.0	74.9	85.00	14.0870
80	81.289	17	1566	1.3	MRD63	11900	70.0	92.9	85.00	36.2230	
90	95.524	15	1840	1.1	MRD63	11900	70.0	92.9	85.00	35.6020	
100	104.082	13	2005	1.0	MRD63	11900	70.0	92.9	85.00	34.9800	
125	125.867	11	2424	0.9	MRD63	12000	70.0	92.9	85.00	34.9100	
4	2.25	2.313	605	61	1.3	MRD22	1050	7.9	36.9	130.00	4.7297
	2.25	2.420	579	63	2.7	MRD32	3180	13.5	42.5	130.00	9.9221
	2.25	2.343	598	61	>3.5	MRD42	3000	20.0	49.0	130.00	22.7290
	2.5	2.548	549	67	1.2	MRD22	1160	7.9	36.9	130.00	3.9754
	2.5	2.697	519	71	2.5	MRD32	3330	13.5	42.5	130.00	7.9870
	2.5	2.489	562	65	>3.5	MRD42	3450	20.0	49.0	130.00	18.6630
	2.8	2.846	492	75	1.1	MRD22	1260	7.9	36.9	130.00	3.5687
	2.8	2.983	469	78	2.4	MRD32	3340	13.5	42.5	130.00	6.9959
	2.8	2.929	478	77	>3.5	MRD42	3600	20.0	49.0	130.00	16.4540
	3.15	3.133	447	82	1.1	MRD22	1420	7.9	36.9	130.00	3.3344
	3.15	3.324	421	87	2.2	MRD32	3500	13.5	42.5	130.00	6.3316
	3.15	3.111	450	82	>3.5	MRD42	3750	20.0	49.0	130.00	14.9760
	3.55	3.558	393	93	1.0	MRD22	1470	7.9	36.9	130.00	3.0251
	3.55	3.733	375	98	2.0	MRD32	3520	13.5	42.5	130.00	5.8724
	3.55	3.727	376	98	3.3	MRD42	3900	20.0	49.0	130.00	13.1450
	4	3.917	357	103	0.9	MRD22	1580	7.9	36.9	130.00	2.8587
	4	4.160	337	109	1.9	MRD32	3690	13.5	42.5	130.00	5.1053
	4	3.960	354	104	3.4	MRD42	4000	20.0	49.0	130.00	12.3170
	4.5	4.554	307	119	0.8	MRD22	1680	7.9	36.9	130.00	2.5881
	4.5	4.783	293	125	1.7	MRD32	3770	13.5	42.5	130.00	4.6850
4.5	4.547	308	119	2.9	MRD42	4340	20.0	49.0	130.00	12.1150	

Selezione Motoriduttore - Geared Motor Selection - Getriebemotorauswahl
MRD - 1400 rpm

P ₁ [kW]	i _n	i _r	N ₂ [rpm]	M ₂ [Nm]	FS	Tipo - Size - Größe	F _{r2} [N]	MRD [kg]	FRD [kg]	J _m × 10 ⁻⁴	J ₁ × 10 ⁻⁴
4	5	5.013	279	131	0.8	MRD22	1790	7.9	36.9	130.00	2.5088
	5	5.331	263	140	1.6	MRD32	3880	13.5	42.5	130.00	4.2003
	5	4.830	290	127	2.9	MRD42	4850	20.0	49.0	130.00	10.8083
	5.6	5.674	247	149	2.4	MRD42	4710	20.0	49.0	130.00	12.4830
	5.6	5.561	252	146	>3.5	MRD52	4500	49.0	78.0	130.00	17.7500
	6.3	6.717	208	176	1.0	MRD22	1940	7.9	36.9	130.00	3.1335
	6.3	6.261	224	164	2.2	MRD32	4160	13.5	42.5	130.00	5.7232
	6.3	6.286	223	165	3.3	MRD42	5340	20.0	49.0	130.00	13.6364
	7.1	7.484	187	196	1.1	MRD32	4260	13.5	42.5	130.00	5.0995
	7.1	7.321	191	192	1.7	MRD42	5480	20.0	49.0	130.00	12.4340
	7.1	7.305	192	191	3.3	MRD52	4800	49.0	78.0	130.00	18.3510
	8	8.267	169	217	0.8	MRD22	2100	7.9	36.9	130.00	2.7786
	8	7.717	181	202	1.8	MRD32	4330	13.5	42.5	130.00	4.8413
	8	7.857	178	206	2.7	MRD42	5620	20.0	49.0	130.00	11.7587
	8	8.185	171	214	>3.5	MRD52	5200	49.0	78.0	130.00	16.4630
	9	9.124	153	239	1.2	MRD42	5760	20.0	49.0	130.00	10.9430
	9	9.353	150	245	2.1	MRD52	5300	49.0	78.0	130.00	15.1540
	9	8.700	161	228	>3.5	MRD62	8000	62.0	91.0	130.00	40.4220
	10	9.658	145	253	1.5	MRD32	4500	13.5	42.5	130.00	4.1539
	10	10.000	140	262	2.1	MRD42	5920	20.0	49.0	130.00	10.3311
	10	9.915	141	260	>3.5	MRD52	5500	49.0	78.0	130.00	14.4630
	11.2	11.049	127	290	0.7	MRD42	5880	20.0	49.0	130.00	9.9372
	11.2	11.310	124	296	1.4	MRD52	6000	49.0	78.0	130.00	13.8310
	11.2	11.734	119	307	2.8	MRD62	9000	62.0	91.0	130.00	35.1550
	12.5	12.375	113	324	1.2	MRD32	4650	13.5	42.5	130.00	3.6208
	12.5	12.199	115	320	1.8	MRD42	6150	20.0	49.0	130.00	9.4739
	12.5	12.222	115	320	3.4	MRD52	6900	49.0	78.0	130.00	13.2640
	12.5	12.444	113	326	>3.5	MRD62	10300	62.0	91.0	130.00	34.1060
	16	16.451	85	431	0.9	MRD32	2900	13.5	42.5	130.00	3.6755
	16	15.223	92	399	1.4	MRD42	6380	20.0	49.0	130.00	8.7672
	16	15.452	91	405	2.7	MRD52	8500	49.0	78.0	130.00	12.2740
	16	15.733	89	412	>3.5	MRD62	12800	62.0	91.0	130.00	31.5620
	20	19.362	72	507	0.8	MRD32	2500	13.5	42.5	130.00	3.3312
	20	19.643	71	515	1.1	MRD42	6590	20.0	49.0	130.00	8.1877
	20	20.298	69	532	2.1	MRD52	8700	49.0	78.0	130.00	11.4630
	20	20.667	68	542	3.5	MRD62	13000	62.0	91.0	130.00	29.4770
	25	24.478	57	641	0.9	MRD42	4290	20.0	49.0	130.00	7.8266
	25	25.989	54	681	1.6	MRD52	9000	49.0	78.0	130.00	10.9630
	25	24.615	57	645	3.0	MRD62	13500	62.0	91.0	130.00	28.1880
	31.5	29.643	47	777	0.7	MRD42	4000	20.0	49.0	130.00	7.6050
	31.5	31.429	45	824	1.4	MRD52	9100	49.0	78.0	130.00	10.6470
	31.5	33.200	42	870	2.3	MRD62	13700	62.0	91.0	130.00	27.3780
	40	39.333	36	1010	1.1	MRD53	7600	52.0	81.0	130.00	10.5260
	40	40.500	35	1061	1.3	MRD62	15700	62.0	91.0	130.00	27.9190
	40	39.708	35	1020	2.0	MRD63	11400	70.0	99.0	130.00	27.0660
	50	47.984	29	1232	0.9	MRD53	7800	52.0	81.0	130.00	13.8540
	50	49.800	28	1305	1.1	MRD62	16800	62.0	91.0	130.00	27.2030
	50	48.948	29	1257	1.6	MRD63	11700	70.0	99.0	130.00	35.6250
	63	59.878	23	1538	0.8	MRD53	7800	52.0	81.0	130.00	14.3910
	63	56.000	25	1467	1.0	MRD62	18000	62.0	91.0	130.00	26.5900



Selezione Motoriduttore - Geared Motor Selection - Getriebemotorauswahl

MRD - 1400 rpm

P ₁ [kW]	i _n	i _r	N ₂ [rpm]	M ₂ [Nm]	FS	Tipo - Size - Größe	F _{r2} [N]	MRD [kg]	FRD [kg]	J _m × 10 ⁻⁴	J ₁ × 10 ⁻⁴
4	63	61.884	23	1589	1.3	MRD63	11700	70.0	99.0	130.00	37.0040
	80	81.289	17	2087	1.0	MRD63	11900	70.0	99.0	130.00	36.2230
	90	95.524	15	2453	0.8	MRD63	11900	70.0	99.0	130.00	35.6020
	100	104.082	13	2673	0.8	MRD63	11900	70.0	99.0	130.00	34.9800
5.5	2.25	2.343	598	84	3.3	MRD42	3500	20.0	59.0	240.00	21.3653
	2.5	2.489	562	90	3.3	MRD42	3950	20.0	59.0	240.00	17.5055
	2.8	2.929	478	106	2.9	MRD42	4080	20.0	59.0	240.00	15.1377
	3.15	3.111	450	112	2.9	MRD42	4167	20.0	59.0	240.00	13.8183
	3.55	3.727	376	134	2.4	MRD42	4260	20.0	59.0	240.00	11.9620
	3.55	3.568	392	129	>3.5	MRD52	3900	49.0	88.0	240.00	18.5780
	4	3.960	354	143	2.5	MRD42	4350	20.0	59.0	240.00	11.1597
	4	3.926	357	141	>3.5	MRD52	4000	49.0	88.0	240.00	17.2440
	4.5	4.547	308	164	2.1	MRD42	4420	20.0	59.0	240.00	10.7824
	4.5	4.398	318	158	>3.5	MRD52	4300	49.0	88.0	240.00	16.4210
	5	4.830	290	174	2.1	MRD42	4580	20.0	59.0	240.00	9.6510
	5	4.840	289	174	>3.5	MRD52	4500	49.0	88.0	240.00	15.1310
	5.6	5.674	247	204	1.8	MRD42	4740	20.0	59.0	240.00	11.4844
	5.6	5.561	252	200	>3.5	MRD52	4500	49.0	88.0	240.00	17.7500
	6.3	6.286	223	226	2.4	MRD42	5050	20.0	59.0	240.00	12.4792
	6.3	6.454	217	233	>3.5	MRD52	4600	49.0	88.0	240.00	23.2900
	7.1	7.321	191	264	1.2	MRD42	5180	20.0	59.0	240.00	11.1906
	7.1	7.305	192	263	2.4	MRD52	4800	49.0	88.0	240.00	18.3510
	7.1	7.305	192	263	>3.5	MRD62	7200	62.0	101.0	240.00	45.4250
	8	7.857	178	283	2.0	MRD42	5270	20.0	59.0	240.00	10.6015
	8	8.185	171	295	>3.5	MRD52	5200	49.0	88.0	240.00	16.4630
	9	9.124	153	329	0.9	MRD42	5400	20.0	59.0	240.00	9.8487
	9	9.353	150	337	1.5	MRD52	5300	49.0	88.0	240.00	15.1540
	9	8.700	161	313	>3.5	MRD62	8000	62.0	101.0	240.00	40.4220
	10	10.000	140	360	1.6	MRD42	4810	20.0	59.0	240.00	9.1738
	10	9.915	141	357	3.0	MRD52	5500	49.0	88.0	240.00	14.4630
	10	10.095	139	364	>3.5	MRD62	8300	62.0	101.0	240.00	37.1920
	11.2	11.310	124	407	1.0	MRD52	6000	49.0	88.0	240.00	13.8310
	11.2	11.734	119	423	2.0	MRD62	9000	62.0	101.0	240.00	35.1550
	12.5	12.199	115	440	1.3	MRD42	5610	20.0	59.0	240.00	8.3166
	12.5	12.222	115	440	2.5	MRD52	6900	49.0	88.0	240.00	13.2640
	12.5	12.444	113	448	>3.5	MRD62	10300	62.0	101.0	240.00	34.1060
16	15.223	92	548	1.0	MRD42	5710	20.0	59.0	240.00	7.6100	
16	15.452	91	557	2.0	MRD52	8500	49.0	88.0	240.00	12.2740	
16	15.733	89	567	3.3	MRD62	12800	62.0	101.0	240.00	31.5620	
20	19.643	71	708	0.8	MRD42	5260	20.0	59.0	240.00	7.0305	
20	20.298	69	731	1.5	MRD52	8700	49.0	88.0	240.00	11.4630	
20	20.667	68	745	2.6	MRD62	13000	62.0	101.0	240.00	29.4770	
25	25.989	54	936	1.2	MRD52	9000	49.0	88.0	240.00	10.9630	
25	24.615	57	887	2.2	MRD62	13500	62.0	101.0	240.00	28.1880	
31.5	31.429	45	1132	1.0	MRD52	9100	49.0	88.0	240.00	10.6470	
31.5	33.200	42	1196	1.6	MRD62	13700	62.0	101.0	240.00	27.3780	
40	39.333	36	1389	0.8	MRD53	7600	52.0	91.0	240.00	10.5260	
40	40.500	35	1459	1.0	MRD62	15700	62.0	101.0	240.00	27.9190	
40	39.708	35	1402	1.4	MRD63	11400	70.0	109.0	240.00	27.0660	
50	49.800	28	1794	0.8	MRD62	16800	62.0	101.0	240.00	27.2030	

Selezione Motoriduttore - Geared Motor Selection - Getriebemotorauswahl
RD
MRD - 1400 rpm

P ₁ [kW]	i _n	i _r	N ₂ [rpm]	M ₂ [Nm]	FS	Tipo - Size - Größe	F _{r2} [N]	MRD [kg]	FRD [kg]	J _m × 10 ⁻⁴	J ₁ × 10 ⁻⁴
5.5	50	48.948	29	1728	1.2	MRD63	11700	70.0	109.0	240.00	35.6250
	63	61.884	23	2185	0.9	MRD63	11700	70.0	109.0	240.00	37.0040
7.5	2.25	2.343	598	115	2.4	MRD42	5340	20.0	68.5	330.00	6.7309
	2.25	2.323	603	114	>3.5	MRD52	3200	49.0	97.5	330.00	31.6570
	2.5	2.489	562	122	2.4	MRD42	3760	20.0	68.5	330.00	17.5055
	2.5	2.556	548	126	>3.5	MRD52	3400	49.0	97.5	330.00	26.1280
	2.8	2.929	478	144	2.1	MRD42	3840	20.0	68.5	330.00	15.4668
	2.8	2.945	475	145	>3.5	MRD52	3500	49.0	97.5	330.00	24.1540
	3.15	3.111	450	153	2.1	MRD42	3940	20.0	68.5	330.00	13.8183
	3.15	3.241	432	159	>3.5	MRD52	3700	49.0	97.5	330.00	20.9660
	3.55	3.727	376	183	1.8	MRD42	4000	20.0	68.5	330.00	11.9620
	3.55	3.568	392	175	>3.5	MRD52	3900	49.0	97.5	330.00	18.5780
	4	3.960	354	195	1.8	MRD42	4050	20.0	68.5	330.00	11.1597
	4	3.926	357	193	>3.5	MRD52	4000	49.0	97.5	330.00	17.2440
	4.5	4.547	308	223	1.5	MRD42	4090	20.0	68.5	330.00	10.7824
	4.5	4.398	318	216	3.2	MRD52	4300	49.0	97.5	330.00	16.4210
	5	4.830	290	237	1.5	MRD42	4230	20.0	68.5	330.00	9.6510
	5	4.840	289	238	3.2	MRD52	4500	49.0	97.5	330.00	15.1310
	5.6	5.674	247	279	1.3	MRD42	4380	20.0	68.5	330.00	11.4844
	5.6	5.561	252	273	2.6	MRD52	4500	49.0	97.5	330.00	17.7500
	5.6	5.561	252	273	>3.5	MRD62	6800	62.0	110.5	330.00	42.7800
	6.3	6.286	223	309	1.8	MRD42	4500	20.0	68.5	330.00	12.4792
	6.3	6.454	217	317	3.3	MRD52	4600	49.0	97.5	330.00	23.2900
	6.3	6.571	213	323	>3.5	MRD62	6900	62.0	110.5	330.00	59.8900
	7.1	7.321	191	360	0.9	MRD42	4750	20.0	68.5	330.00	11.1906
	7.1	7.305	192	359	1.8	MRD52	4800	49.0	97.5	330.00	18.3510
	7.1	7.305	192	359	3.5	MRD62	7200	62.0	110.5	330.00	45.4250
	8	7.857	178	386	1.4	MRD42	4820	20.0	68.5	330.00	10.6015
	8	8.185	171	402	2.6	MRD52	5200	49.0	97.5	330.00	16.4630
	8	8.333	168	409	>3.5	MRD62	7800	62.0	110.5	330.00	42.3320
	9	9.353	150	460	1.1	MRD52	5300	49.0	97.5	330.00	15.1540
	9	8.700	161	427	2.7	MRD62	8000	62.0	110.5	330.00	40.4220
	10	10.000	140	491	1.1	MRD42	4900	20.0	68.5	330.00	9.1738
	10	9.915	141	487	2.2	MRD52	5500	49.0	97.5	330.00	14.4630
	10	10.095	139	496	>3.5	MRD62	8300	62.0	110.5	330.00	37.1920
11.2	11.310	124	556	0.7	MRD52	6000	49.0	97.5	330.00	13.8310	
11.2	11.734	119	577	1.5	MRD62	9000	62.0	110.5	330.00	35.1550	
12.5	12.199	115	599	0.9	MRD42	4590	20.0	68.5	330.00	8.3166	
12.5	12.222	115	600	1.8	MRD52	6900	49.0	97.5	330.00	13.2640	
12.5	12.444	113	611	3.1	MRD62	10300	62.0	110.5	330.00	34.1060	
16	15.223	92	748	0.8	MRD42	5100	20.0	68.5	330.00	7.6100	
16	15.452	91	759	1.4	MRD52	8500	49.0	97.5	330.00	12.2740	
16	15.733	89	773	2.4	MRD62	12800	62.0	110.5	330.00	31.5620	
20	20.298	69	997	1.1	MRD52	8700	49.0	97.5	330.00	11.4630	
20	20.667	68	1015	1.9	MRD62	13000	62.0	110.5	330.00	29.4770	
25	25.989	54	1277	0.9	MRD52	9000	49.0	97.5	330.00	10.9630	
25	24.615	57	1209	1.6	MRD62	13500	62.0	110.5	330.00	28.1880	
31.5	31.429	45	1544	0.7	MRD52	9100	49.0	97.5	330.00	10.6470	
31.5	33.200	42	1631	1.2	MRD62	13700	62.0	110.5	330.00	27.3780	
40	39.708	35	1912	1.0	MRD63	11400	70.0	118.5	330.00	27.0660	



Selezione Motoriduttore - Geared Motor Selection - Getriebemotorauswahl

MRD - 1400 rpm

P ₁ [kW]	i _n	i _r	N ₂ [rpm]	M ₂ [Nm]	FS	Tipo - Size - Größe	F _{r2} [N]	MRD [kg]	FRD [kg]	J _m × 10 ⁻⁴	J ₁ × 10 ⁻⁴
7.5	50	48.948	29	2357	0.9	MRD63	11700	70.0	118.5	330.00	35.6250
9.2	2.25	2.343	598	141	2.0	MRD42	3140	20.0	76.5	340.00	21.3653
	2.25	2.323	603	140	>3.5	MRD52	3200	49.0	105.5	340.00	31.6570
	2.5	2.489	562	150	2.0	MRD42	3610	20.0	76.5	340.00	17.5060
	2.5	2.556	548	154	>3.5	MRD52	3400	49.0	105.5	340.00	26.1280
	2.8	2.929	478	177	1.7	MRD42	3670	20.0	76.5	340.00	15.1377
	2.8	2.945	475	177	3.5	MRD52	3500	49.0	105.5	340.00	24.1540
	3.15	3.111	450	187	1.7	MRD42	3750	20.0	76.5	340.00	13.8180
	3.15	3.241	432	195	3.5	MRD52	3700	49.0	105.5	340.00	20.9660
	3.55	3.727	376	225	1.4	MRD42	3800	20.0	76.5	340.00	11.9620
	3.55	3.568	392	215	3.1	MRD52	3900	49.0	105.5	340.00	18.5780
	4	3.960	354	239	1.5	MRD42	3870	20.0	76.5	340.00	11.1600
	4	3.926	357	237	3.1	MRD52	4000	49.0	105.5	340.00	17.2440
	4.5	4.547	308	274	1.2	MRD42	3810	20.0	76.5	340.00	10.7824
	4.5	4.398	318	265	2.6	MRD52	4300	49.0	105.5	340.00	16.4210
	4.5	4.398	318	265	>3.5	MRD62	6400	62.0	118.5	340.00	42.7240
	5	4.830	290	291	1.2	MRD42	3940	20.0	76.5	340.00	9.6510
	5	4.840	289	292	2.6	MRD52	4500	49.0	105.5	340.00	15.1310
	5	4.955	283	299	>3.5	MRD62	6700	62.0	118.5	340.00	38.9090
	5.6	5.674	247	342	1.0	MRD42	4080	20.0	76.5	340.00	11.4844
	5.6	5.561	252	335	2.1	MRD52	4500	49.0	105.5	340.00	17.7500
	5.6	5.561	252	335	>3.5	MRD62	6800	62.0	118.5	340.00	42.7800
	6.3	6.286	223	379	1.4	MRD42	4380	20.0	76.5	340.00	12.4790
	6.3	6.454	217	389	2.7	MRD52	4600	49.0	105.5	340.00	23.2900
	6.3	6.571	213	396	>3.5	MRD62	6900	62.0	118.5	340.00	59.8900
	7.1	7.321	191	441	0.7	MRD42	4420	20.0	76.5	340.00	11.1906
	7.1	7.305	192	440	1.4	MRD52	4800	49.0	105.5	340.00	18.3510
	7.1	7.305	192	440	2.9	MRD62	7200	62.0	118.5	340.00	45.4250
	8	7.857	178	474	1.2	MRD42	4430	20.0	76.5	340.00	10.6020
	8	8.185	171	493	2.1	MRD52	5200	49.0	105.5	340.00	16.4630
	8	8.333	168	502	>3.5	MRD62	7800	62.0	118.5	340.00	42.3320
9	9.353	150	564	0.9	MRD52	5300	49.0	105.5	340.00	15.1540	
9	8.700	161	524	2.2	MRD62	8000	62.0	118.5	340.00	40.4220	
10	10.000	140	603	0.9	MRD42	3700	20.0	76.5	340.00	9.1738	
10	9.915	141	598	1.8	MRD52	5500	49.0	105.5	340.00	14.4630	
10	10.095	139	608	3.0	MRD62	8300	62.0	118.5	340.00	37.1920	
11.2	11.734	119	707	1.2	MRD62	9000	62.0	118.5	340.00	35.1550	
12.5	12.199	115	735	0.8	MRD42	3000	20.0	76.5	340.00	8.3166	
12.5	12.222	115	737	1.5	MRD52	6900	49.0	105.5	340.00	13.2640	
12.5	12.444	113	750	2.5	MRD62	10300	62.0	118.5	340.00	34.1060	
16	15.452	91	931	1.2	MRD52	8500	49.0	105.5	340.00	12.2740	
16	15.733	89	948	2.0	MRD62	12800	62.0	118.5	340.00	31.5620	
20	20.298	69	1223	0.9	MRD52	8700	49.0	105.5	340.00	11.4630	
20	20.667	68	1246	1.5	MRD62	13000	62.0	118.5	340.00	29.4770	
25	24.615	57	1483	1.3	MRD62	13500	62.0	118.5	340.00	28.1880	
31.5	33.200	42	2001	1.0	MRD62	13700	62.0	118.5	340.00	27.3780	
40	39.708	35	2345	0.9	MRD63	11400	70.0	126.5	340.00	27.0660	
11	2.25	2.323	603	167	>3.5	MRD52	3200	49.0	122.0	620.00	31.6570
	2.5	2.556	548	184	3.4	MRD52	3400	49.0	122.0	620.00	26.1280
	2.8	2.945	475	212	2.9	MRD52	3500	49.0	122.0	620.00	24.1540

Selezione Motoriduttore - Geared Motor Selection - Getriebemotorauswahl
RD
MRD - 1400 rpm

P ₁ [kW]	i _n	i _r	N ₂ [rpm]	M ₂ [Nm]	FS	Tipo - Size - Größe	F _{r2} [N]	MRD [kg]	FRD [kg]	J _m × 10 ⁻⁴	J ₁ × 10 ⁻⁴
11	3.15	3.241	432	234	2.9	MRD52	3700	49.0	122.0	620.00	20.9660
	3.55	3.568	392	257	2.6	MRD52	3900	49.0	122.0	620.00	18.5780
	3.55	3.568	392	257	>3.5	MRD62	5800	62.0	135.0	620.00	49.3940
	4	3.926	357	283	2.6	MRD52	4000	49.0	122.0	620.00	17.2440
	4	4.019	348	290	>3.5	MRD62	6000	62.0	135.0	620.00	44.3410
	4.5	4.398	318	317	2.2	MRD52	4300	49.0	122.0	620.00	16.4210
	4.5	4.398	318	317	>3.5	MRD62	6400	62.0	135.0	620.00	42.7240
	5	4.840	289	349	2.2	MRD52	4500	49.0	122.0	620.00	15.1310
	5	4.955	283	357	>3.5	MRD62	6700	62.0	135.0	620.00	38.9090
	5.6	5.561	252	401	1.8	MRD52	4500	49.0	122.0	620.00	17.7500
	5.6	5.561	252	401	>3.5	MRD62	6800	62.0	135.0	620.00	42.7800
	6.3	6.454	217	465	2.2	MRD52	4600	49.0	122.0	620.00	23.2900
	6.3	6.571	213	473	>3.5	MRD62	6900	62.0	135.0	620.00	59.8900
	7.1	7.305	192	526	1.2	MRD52	4800	49.0	122.0	620.00	18.3510
	7.1	7.305	192	526	2.4	MRD62	7200	62.0	135.0	620.00	45.4250
	8	8.185	171	590	1.8	MRD52	5200	49.0	122.0	620.00	16.4630
	8	8.333	168	600	3.1	MRD62	7800	62.0	135.0	620.00	42.3320
	9	9.353	150	674	0.8	MRD52	5300	49.0	122.0	620.00	15.1540
	9	8.700	161	627	1.8	MRD62	8000	62.0	135.0	620.00	40.4220
	10	9.915	141	714	1.5	MRD52	5500	49.0	122.0	620.00	14.4630
10	10.095	139	727	2.5	MRD62	8300	62.0	135.0	620.00	37.1920	
11.2	11.734	119	846	1.0	MRD62	9000	62.0	135.0	620.00	35.1550	
12.5	12.222	115	881	1.2	MRD52	6900	49.0	122.0	620.00	13.2640	
12.5	12.444	113	897	2.1	MRD62	10300	62.0	135.0	620.00	34.1060	
16	15.452	91	1113	1.0	MRD52	8500	49.0	122.0	620.00	12.2740	
16	15.733	89	1134	1.7	MRD62	12800	62.0	135.0	620.00	31.5620	
20	20.298	69	1463	0.8	MRD52	8700	49.0	122.0	620.00	11.4630	
20	20.667	68	1489	1.3	MRD62	13000	62.0	135.0	620.00	29.4770	
25	24.615	57	1774	1.1	MRD62	13500	62.0	135.0	620.00	28.1880	
31.5	33.200	42	2392	0.8	MRD62	13700	62.0	135.0	620.00	27.3780	
15	2.25	2.323	603	228	2.8	MRD52	3200	49.0	149.0	740.00	31.6570
	2.25	2.323	603	228	>3.5	MRD62	4800	62.0	162.0	740.00	85.2050
	2.5	2.556	548	251	2.5	MRD52	3400	49.0	149.0	740.00	26.1280
	2.5	2.616	535	257	>3.5	MRD62	5100	62.0	162.0	740.00	67.1870
	2.8	2.945	475	289	2.2	MRD52	3500	49.0	149.0	740.00	24.1540
	2.8	2.945	475	289	>3.5	MRD62	5400	62.0	162.0	740.00	58.5150
	3.15	3.241	432	318	2.2	MRD52	3700	49.0	149.0	740.00	20.9660
	3.15	3.318	422	326	>3.5	MRD62	5600	62.0	162.0	740.00	53.9140
	3.55	3.568	392	351	1.9	MRD52	3900	49.0	149.0	740.00	18.5780
	3.55	3.568	392	351	>3.5	MRD62	5800	62.0	162.0	740.00	49.3940
	4	3.926	357	386	1.9	MRD52	4000	49.0	149.0	740.00	17.2440
	4	4.019	348	395	>3.5	MRD62	6000	62.0	162.0	740.00	44.3410
	4.5	4.398	318	432	1.6	MRD52	4300	49.0	149.0	740.00	16.4210
	4.5	4.398	318	432	3.2	MRD62	6400	62.0	162.0	740.00	42.7240
	5	4.840	289	476	1.6	MRD52	4500	49.0	149.0	740.00	15.1310
	5	4.955	283	487	3.2	MRD62	6700	62.0	162.0	740.00	38.9090
	5.6	5.561	252	546	1.3	MRD52	4500	49.0	149.0	740.00	17.7500
	5.6	5.561	252	546	2.6	MRD62	6800	62.0	162.0	740.00	42.7800
	6.3	6.454	217	634	1.6	MRD52	4600	49.0	149.0	740.00	23.2900
	6.3	6.571	213	646	2.8	MRD62	6900	62.0	162.0	740.00	59.8900



Selezione Motoriduttore - Geared Motor Selection - Getriebemotorauswahl

MRD - 1400 rpm

P ₁ [kW]	i _n	i _r	N ₂ [rpm]	M ₂ [Nm]	FS	Tipo - Size - Größe	F _{r2} [N]	MRD [kg]	FRD [kg]	J _m × 10 ⁻⁴	J ₁ × 10 ⁻⁴
15	7.1	7.305	192	718	0.9	MRD52	4800	49.0	149.0	740.00	18.3510
	7.1	7.305	192	718	1.8	MRD62	7200	62.0	162.0	740.00	45.4250
	8	8.185	171	804	1.3	MRD52	5200	49.0	149.0	740.00	16.4630
	8	8.333	168	819	2.2	MRD62	7800	62.0	162.0	740.00	42.3320
	9	8.700	161	855	1.3	MRD62	8000	62.0	162.0	740.00	40.4220
	10	9.915	141	974	1.1	MRD52	5500	49.0	149.0	740.00	14.4630
	10	10.095	139	992	1.9	MRD62	8300	62.0	162.0	740.00	37.1920
	11.2	11.734	119	1153	0.7	MRD62	9000	62.0	162.0	740.00	35.1550
	12.5	12.222	115	1201	0.9	MRD52	6900	49.0	149.0	740.00	13.2640
	12.5	12.444	113	1223	1.5	MRD62	10300	62.0	162.0	740.00	34.1060
	16	15.733	89	1546	1.2	MRD62	12800	62.0	162.0	740.00	31.5620
	20	20.667	68	2031	0.9	MRD62	13000	62.0	162.0	740.00	29.4770
25	24.615	57	2419	0.8	MRD62	13500	62.0	162.0	740.00	28.1880	
18.5	2.25	2.323	603	282	>3.5	MRD62	4800	62.0	180.0	1300.00	85.2050
	2.5	2.616	535	317	>3.5	MRD62	5100	62.0	180.0	1300.00	67.1870
	2.8	2.945	475	357	3.5	MRD62	5400	62.0	180.0	1300.00	58.5150
	3.15	3.318	422	402	3.5	MRD62	5600	62.0	180.0	1300.00	53.9140
	3.55	3.568	392	432	3.1	MRD62	5800	62.0	180.0	1300.00	49.3940
	4	4.019	348	487	3.1	MRD62	6000	62.0	180.0	1300.00	44.3410
	4.5	4.398	318	533	2.6	MRD62	6400	62.0	180.0	1300.00	42.7240
	5	4.955	283	600	2.6	MRD62	6700	62.0	180.0	1300.00	38.9090
	5.6	5.561	252	674	2.1	MRD62	6800	62.0	180.0	1300.00	42.7800
	6.3	6.571	213	796	2.3	MRD62	6900	62.0	180.0	1300.00	59.8900
	7.1	7.305	192	885	1.4	MRD62	7200	62.0	180.0	1300.00	45.4250
	8	8.333	168	1010	1.8	MRD62	7800	62.0	180.0	1300.00	42.3320
	9	8.700	161	1054	1.1	MRD62	8000	62.0	180.0	1300.00	40.4220
	10	10.095	139	1223	1.5	MRD62	8300	62.0	180.0	1300.00	37.1920
	12.5	12.444	113	1508	1.2	MRD62	10300	62.0	180.0	1300.00	34.1060
	16	15.733	89	1907	1.0	MRD62	12800	62.0	180.0	1300.00	31.5620
20	20.667	68	2505	0.8	MRD62	13000	62.0	180.0	1300.00	29.4770	
22	2.25	2.323	603	335	3.4	MRD62	4800	62.0	190.0	1500.00	85.2050
	2.5	2.616	535	377	3.4	MRD62	5100	62.0	190.0	1500.00	67.1870
	2.8	2.945	475	424	2.9	MRD62	5400	62.0	190.0	1500.00	58.5150
	3.15	3.318	422	478	2.9	MRD62	5600	62.0	190.0	1500.00	53.9140
	3.55	3.568	392	514	2.6	MRD62	5800	62.0	190.0	1500.00	49.3940
	4	4.019	348	579	2.6	MRD62	6000	62.0	190.0	1500.00	44.3410
	4.5	4.398	318	634	2.2	MRD62	6400	62.0	190.0	1500.00	42.7240
	5	4.955	283	714	2.2	MRD62	6700	62.0	190.0	1500.00	38.9090
	5.6	5.561	252	801	1.8	MRD62	6800	62.0	190.0	1500.00	42.7800
	6.3	6.571	213	947	1.9	MRD62	6900	62.0	190.0	1500.00	59.8900
	7.1	7.305	192	1053	1.2	MRD62	7200	62.0	190.0	1500.00	45.4250
	8	8.333	168	1201	1.5	MRD62	7800	62.0	190.0	1500.00	42.3320
	9	8.700	161	1254	0.9	MRD62	8000	62.0	190.0	1500.00	40.4220
	10	10.095	139	1455	1.3	MRD62	8300	62.0	190.0	1500.00	37.1920
	12.5	12.444	113	1793	1.0	MRD62	10300	62.0	190.0	1500.00	34.1060
	16	15.733	89	2267	0.8	MRD62	12800	62.0	190.0	1500.00	31.5620

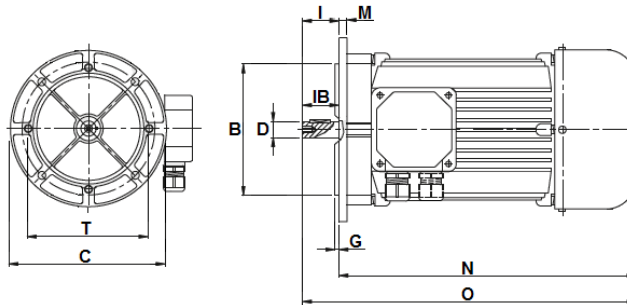
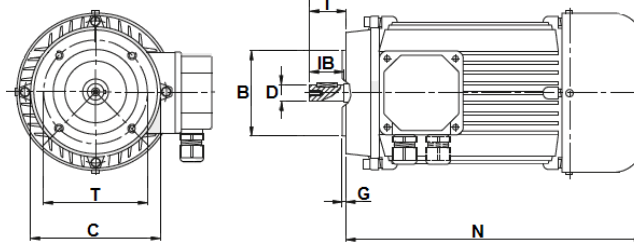
Motori IEC - IEC Motors - IEC-Motoren
RD
IEC - B5

IEC - B14

Taglia Size Größe	2 poli - poles - Polig			4 poli - poles - Polig			6 poli - poles - Polig			Flangia - Flange Flansch B / C / T	Albero Shaft Welle D x l	G	IB	N	O
	kW	rpm	kg	kW	rpm	kg	kW	rpm	kg						
T56A T56B	0.09 0,12	2710 2700	2.6 3.0	0.06 0.09	1360 1360	2.9 3.2	---	---	---	B5 - 120 / 100 / 80 B14 - 80 / 65 / 50	9 x 20	3.0 2.5	20	176	196
T63A T63B	0.18 0.25	2710 2710	4.0 4.2	0.12 0.18	1360 1310	3.7 4.2	0.09 0.12	840 850	4.2 4.5	B5 - 140 / 115 / 95 B14 - 90 / 75 / 60	11 x 23	3.0 2.5	23	197	220
T71A T71B	0.37 0.55	2730 2780	5.2 6.0	0.25 0.37	1350 1370	5.0 5.8	0.18 0.25	880 900	5.6 6.0	B5 - 160 / 130 / 110 B14 - 105 / 85 / 70	14 x 30	3.5 2.5	30	211	241
T80A T80B	0.75 1.1	2770 2770	8.7 10	0.55 0.75	1370 1380	8.1 9.1	0.37 0.55	890 900	6.8 9.6	B5 - 200 / 165 / 130 B14 - 120 / 100 / 80	19 x 40	3.5 3.0	40	250	290
T90S T90L	1.5 2.2	2840 2840	12 14.5	1.1 1.5	1400 1400	11.7 14.4	0.75 1.1	920 925	11.3 14.4	B5 - 200 / 165 / 130 B14 - 140 / 115 / 95	24 x 50	3.5 3.0	50	262 287	312 337
T100A T100B	3 4	2840 2850	20 24	2.2 3	1400 1420	17.6 22.5	1.5 2.2	945 950	18.8 19.8	B5 - 250 / 215 / 180 B14 - 160 / 130 / 110	28 x 60	4.0 3.5	60	309	369
T112A	5.5	2880	29.3	4	1430	29.0	3	950	30.0	B5 - 250 / 215 / 180 B14 - 160 / 130 / 110	28 x 60	4.0 3.5	60	335	395
T132S T132M T132ML	7.5 11 ---	2900 2930 ---	38.4 52.5 ---	5.5 7.5 9.2	1450 1450 1460	39.0 48.5 56.5	4.5 5 7.5	960 60 960	47.6 50.7 47.6	B5 - 300 / 265 / 230 B14 - 200 / 165 / 130	38 x 80	4.0 4.0 ---	80	357 395 421	437 475 501
T160M T160L	15 18.5	2940 2940	77.5 92	11 15	1460 1445	73 100	7.5 11	960 960	70.0 87.0	B5 - 350 / 300 / 250 B14 - 250 / 215 / 180	42 x 110	5.0 4.0	110	530	640
T180M T180L	22 ---	2950 ---	121 ---	18.5 22	1470 1470	118 128	15 ---	970 ---	124 ---	B5 - 350 / 300 / 250	48 x 110	5.0	110	620	730

Dimensioni e pesi non impegnativi

Not binding dimensions and weights

unverbindliche Abmessungen u. Gewichte



RD 02-03

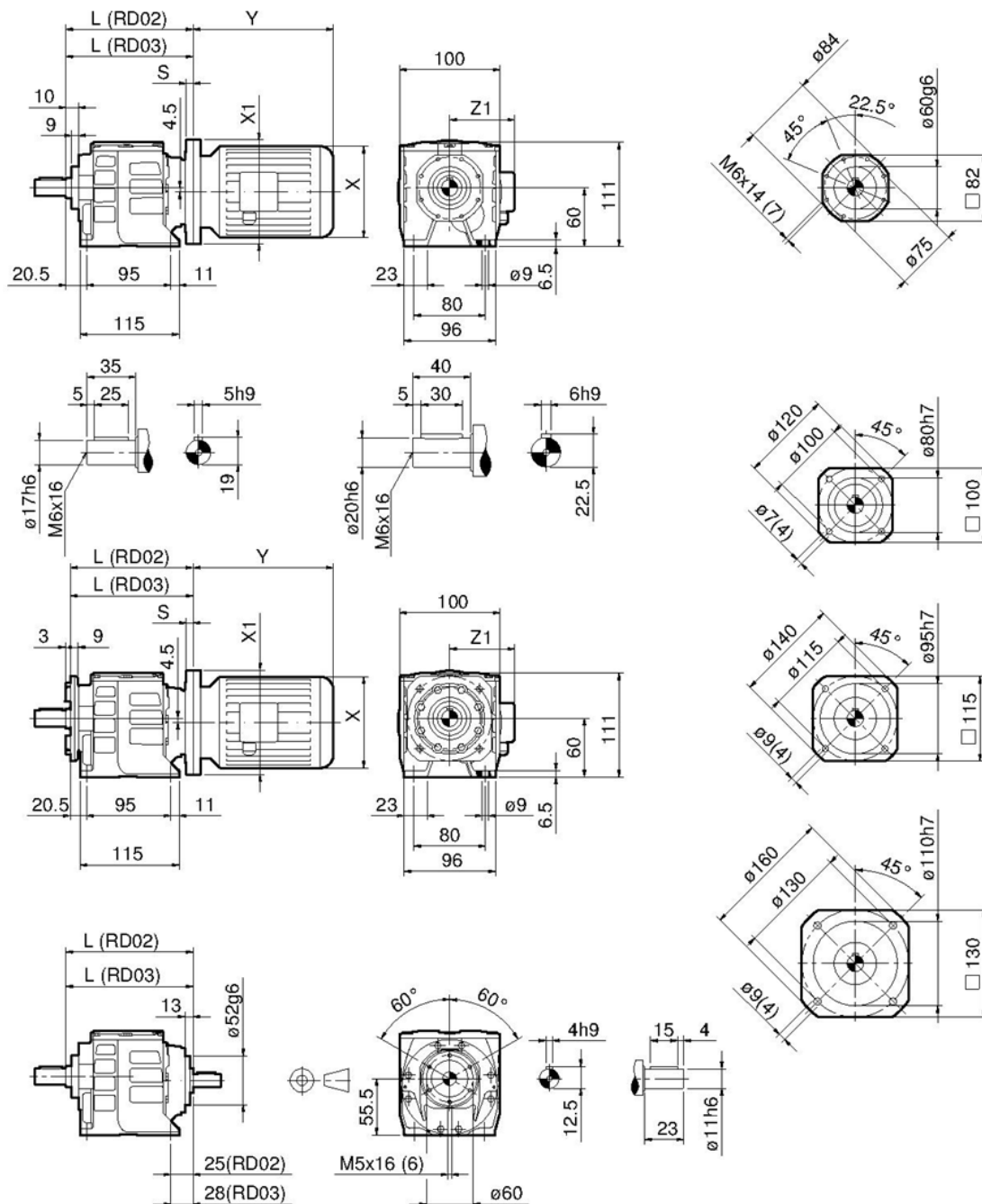

RD	02 / 03	02 / 03	02 / 03	02	---	---	---	---
IEC	56	63	71	80	---	---	---	---
X / Y / Z1	Dimensioni: pag.51 - Dimensions: page 51 - Abmessungen: Seite 51				---	---	---	---
X1 (B5) / S	120/11	140/10	160/11.5	---	---	---	---	---
X1 (B14) / S	80/8	90/10	105/10	120/11	---	---	---	---
L (RD02)	140	140	140	140	---	---	---	---
L (RD03)	143	143	143	---	---	---	---	---

Dimensioni e pesi non impegnativi

Not binding dimensions and weights

unverbindliche Abmessungen u. Gewichte

Dimensioni - Dimensions - Abmessungen

RD

RD 12-13

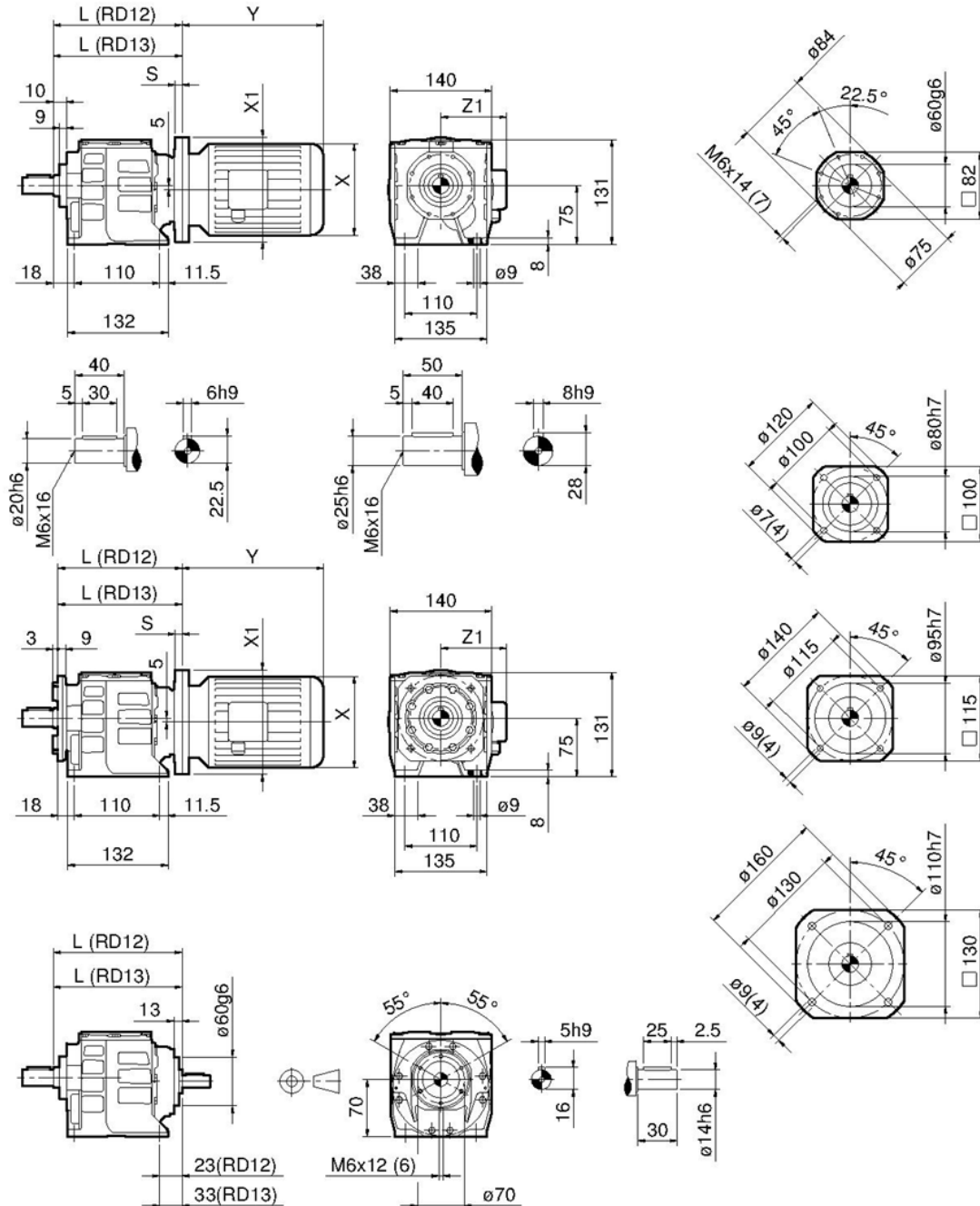

RD	12 / 13	12 / 13	12 / 13	12	12	12	---	---
IEC	56	63	71	80	90 S	90 L	---	---
X / Y / Z1	Dimensioni: pag.51 - Dimensions: page 51 - Abmessungen: Seite 51						---	---
X1 (B5) / S	120/11	140/10	160/11.5	200/11	200/11	200/11	---	---
X1 (B14) / S	---	90/8	105/10	120/11	140/10	140/10	---	---
L (RD12)	151	151	151 [B5] 155 [B14]	151	151	151	---	---
L (RD13)	161	161	161 [B5] 155 [B14]	161	161	161	---	---
Dimensioni e pesi non impegnativi			Not binding dimensions and weights			unverbindliche Abmessungen u. Gewichte		



Dimensioni - Dimensions - Abmessungen

RD 22-23

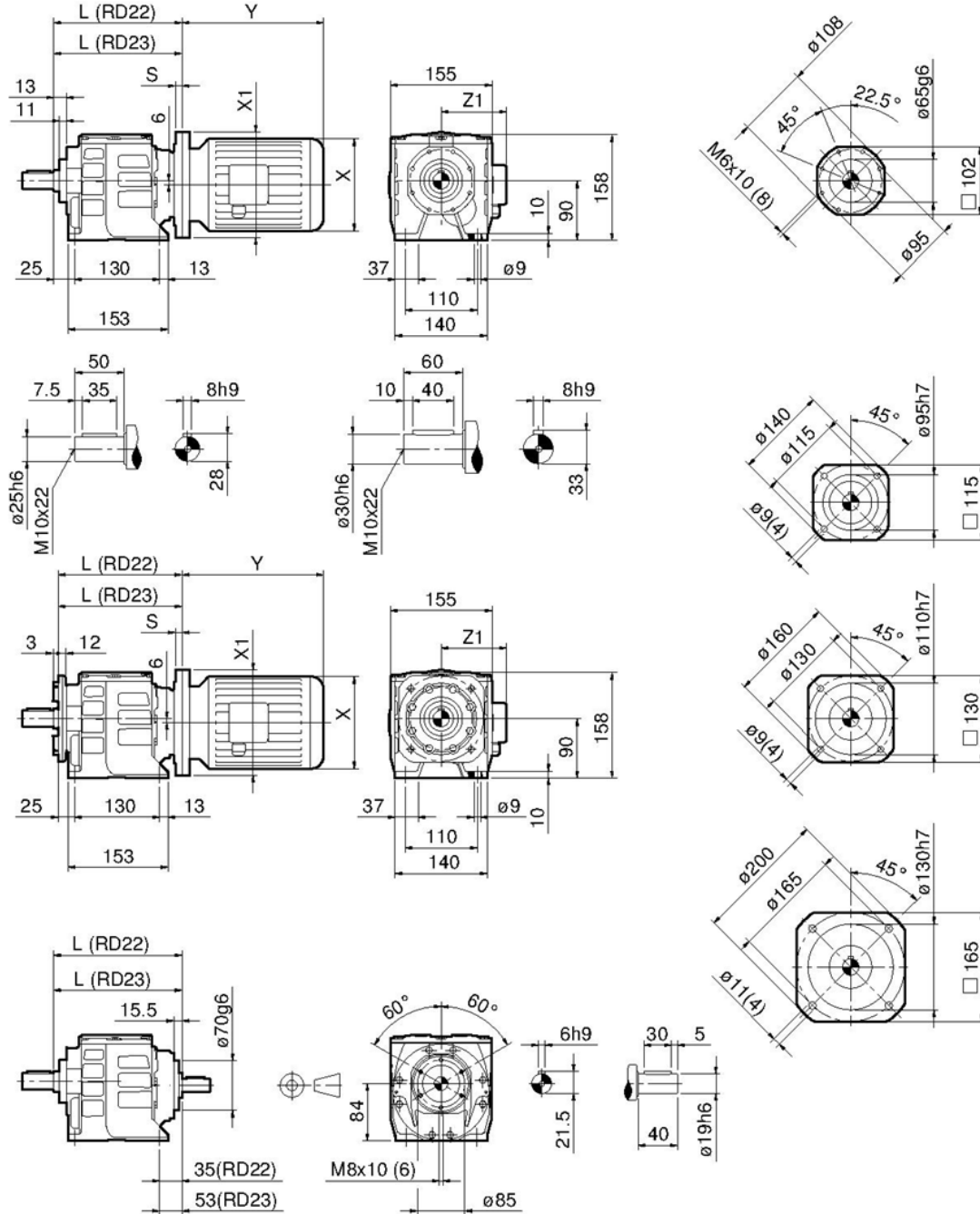

RD	23	22 / 23	22 / 23	22	22	22	22	---
IEC	63	71	80	90 S	90 L	100	112	---
X / Y / Z1	Dimensioni: pag.51 - Dimensions: page 51 - Abmessungen: Seite 51							---
X1 (B5) / S	140/10	160/11.5	200/11	200/11	200/11	250/13	250/13	---
X1 (B14) / S	---	105/10.5	120/10	140/10	140/10	160/11.5	160/11.5	---
L (RD22)	---	190	190	190	190	191	191	---
L (RD23)	211	209	[192-14] 209 [211-14]	---	---	---	---	---
Dimensioni e pesi non impegnativi			Not binding dimensions and weights			unverbindliche Abmessungen u. Gewichte		

Dimensioni - Dimensions - Abmessungen

RD

RD 32-33

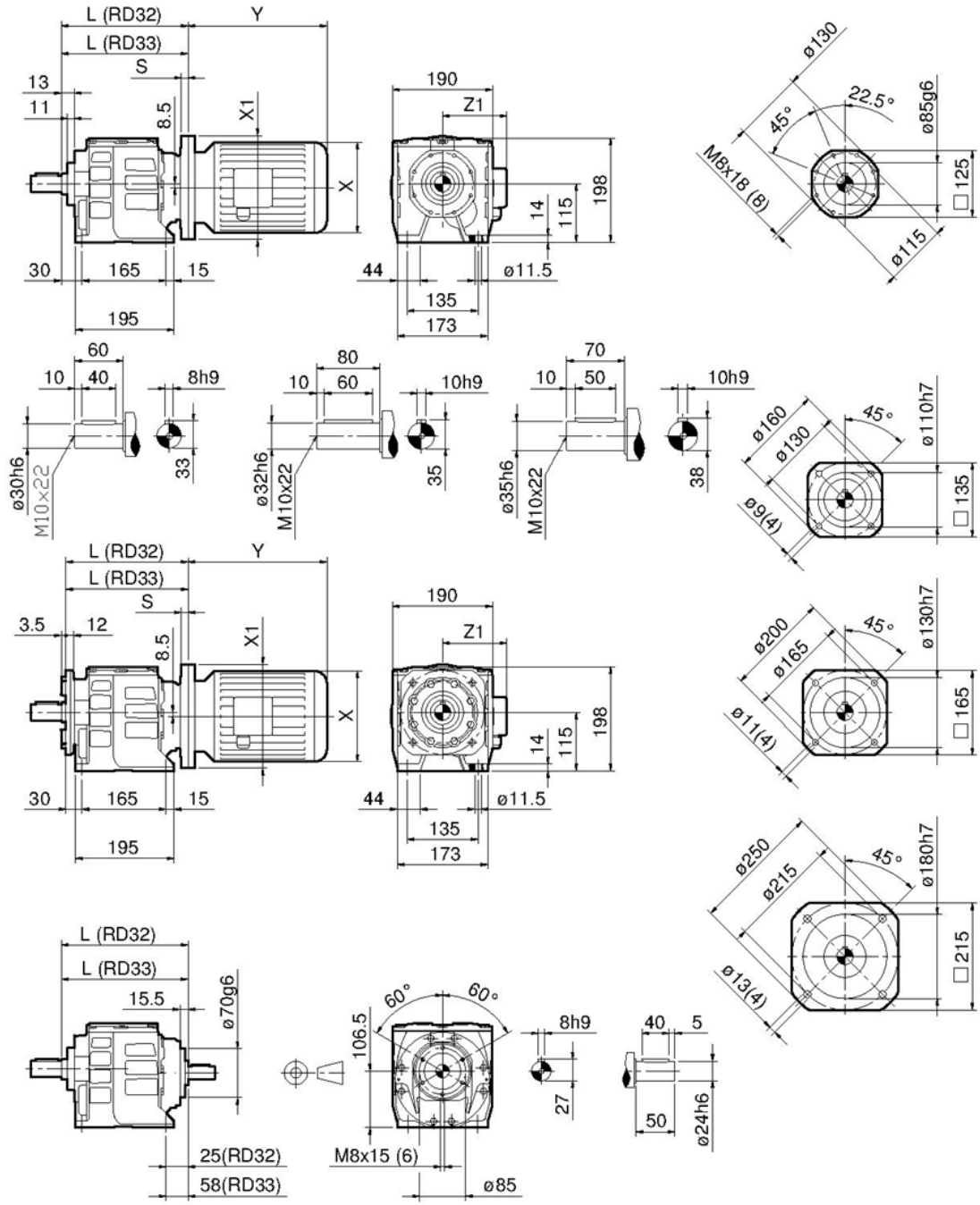

RD	32 / 33	32 / 33	32 / 33	32 / 33	32 / 33	32	---	---
IEC	71	80	90 S	90 L	100	112	---	---
X / Y / Z1	Dimensioni: pag.51 - Dimensions: page 51 - Abmessungen: Seite 51						---	---
X1 (B5) / S	160/11.5	200/11	200/11	200/11	250/13	250/13	---	---
X1 (B14) / S	105/10.5	120/10	140/10	140/10	160/11.5	160/11.5	---	---
L (RD32)	220	220 [B5] 222 [B14]	220 [B5] 222 [B14]	220 [B5] 222 [B14]	228 [B5] 221 [B14]	228 [B5] 221 [B14]	---	---
L (RD33)	253	253 [B5] 255 [B14]	253 [B5] 255 [B14]	253 [B5] 255 [B14]	253 [B5] 255 [B14]	---	---	---

Dimensioni e pesi non impegnativi

Not binding dimensions and weights

unverbindliche Abmessungen u. Gewichte



Dimensioni - Dimensions - Abmessungen

RD 42-43

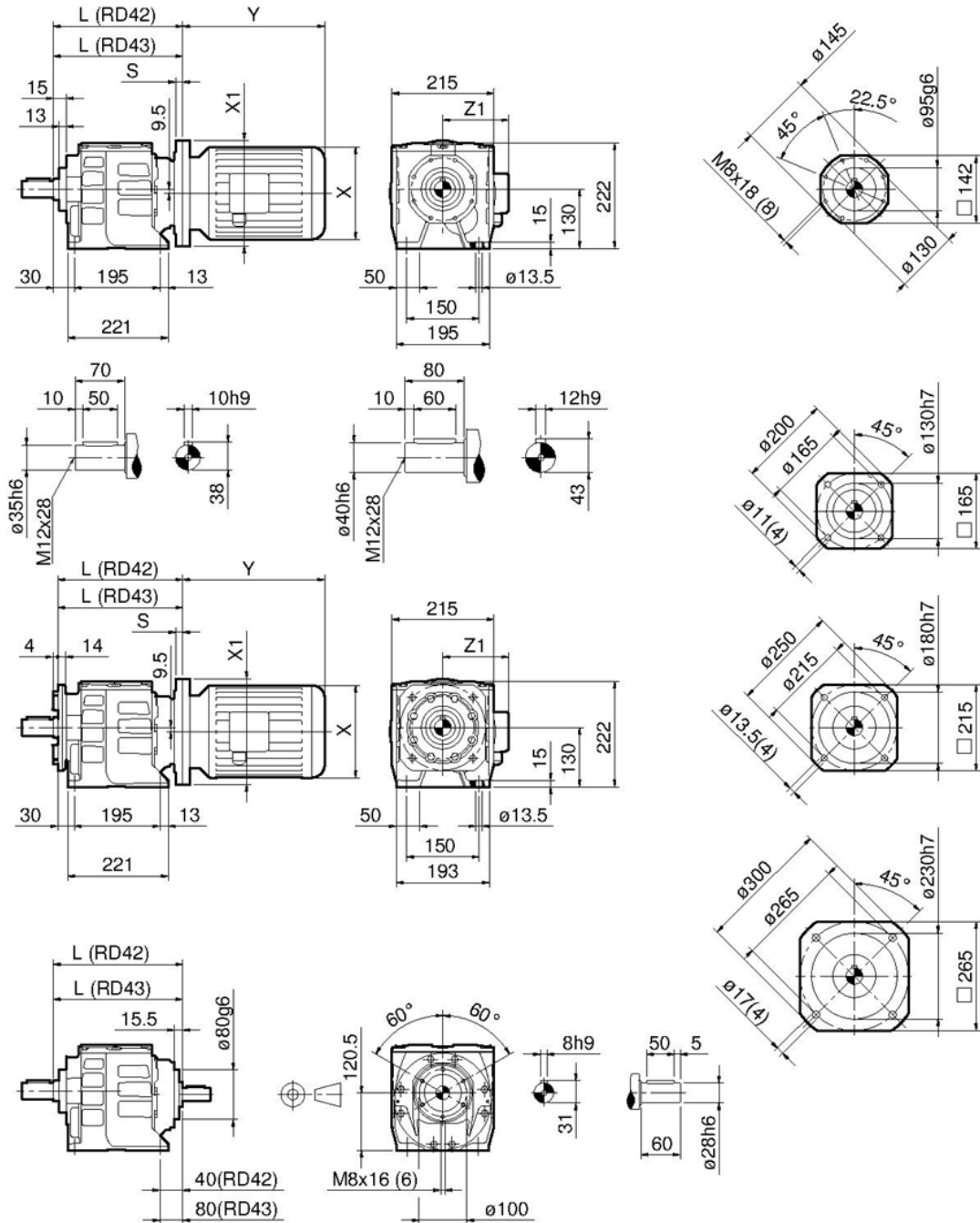

RD	43	42 / 43	42 / 43	42 / 43	42 / 43	42	42	42
IEC	71	80	90 S	90 L	100	112	132 S	132 M
X / Y / Z1	Dimensioni: pag.51 - Dimensions: page 51 - Abmessungen: Seite 51							
X1 (B5) / S	160/11.5	200/11.5	200/11.5	200/11.5	250/14	250/14	300/15	300/15
X1 (B14) / S	---	120/10	140/10	140/10	160/11.5	160/11.5	200/11.5	200/11.5
L (RD42)	---	265	265 [B5] 268 [B14]	265 [B5] 268 [B14]	266 [B5] 264 [B14]	266 [B5] 264 [B14]	268	268
L (RD43)	305	305	305 [B5] 308 [B14]	305 [B5] 308 [B14]	306 [B5] 304 [B14]	---	---	---
Dimensioni e pesi non impegnativi			Not binding dimensions and weights			unverbindliche Abmessungen u. Gewichte		

Dimensioni - Dimensions - Abmessungen

RD

RD 52-53

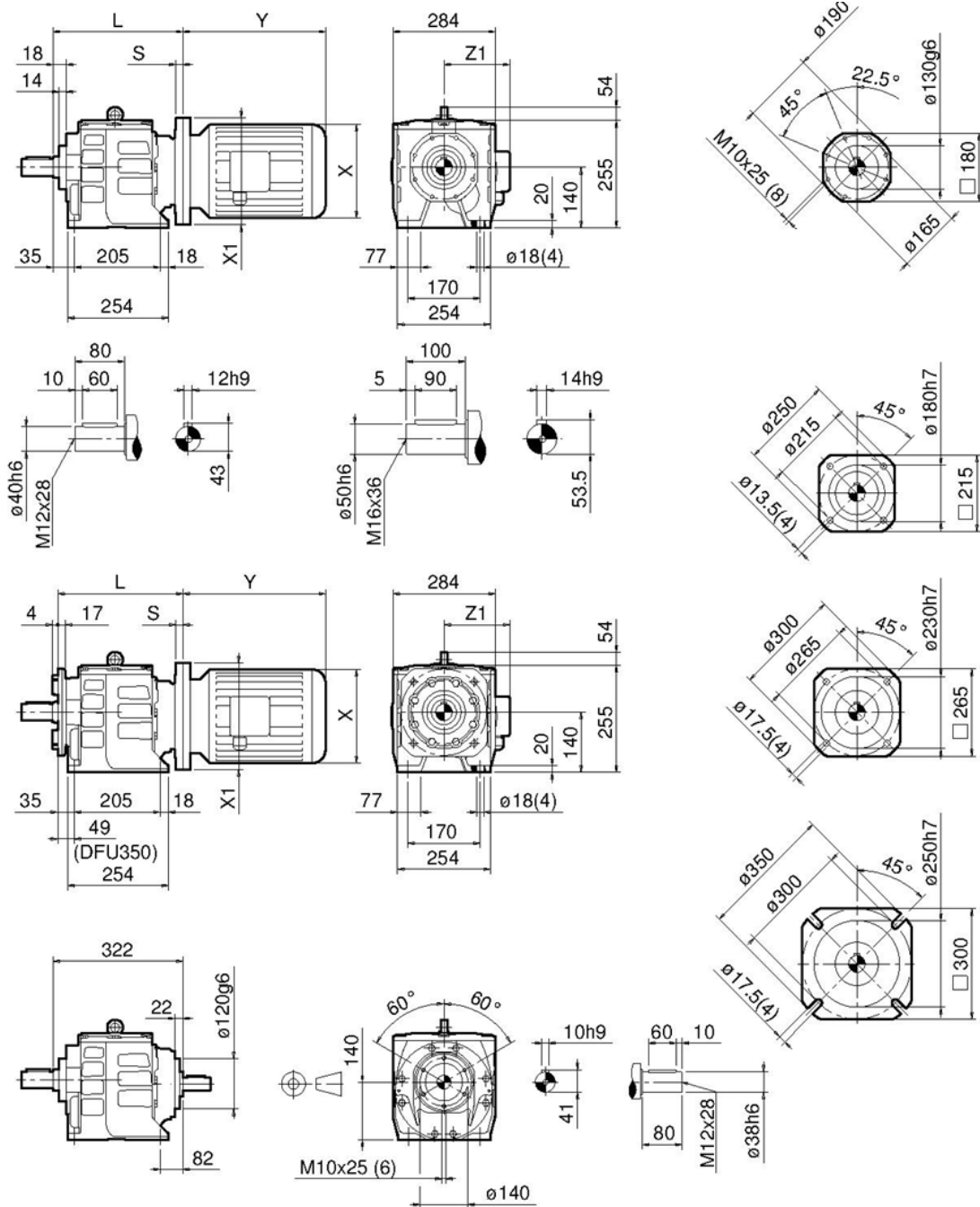

RD	52 / 53	52 / 53	52 / 53	52/53	52/53	52/53	52
IEC	80	90 S	90 L	100	112	132 S/M	160
X / Y / Z1	Dimensioni: pag.51 - Dimensions: page 51 - Abmessungen: Seite 51						
X1 (B5) / S	200/16	200/16	200/16	250/16	250/16	300/16	350/25
X1 (B14) / S	---	---	---	---	---	200/16	---
L	322	322	322	322	322	322	353
L1 / L1(ø350)	322/336	322/336	322/336	322/336	322/336	322/336	353/367

Dimensioni e pesi non impegnativi

Not binding dimensions and weights

unverbindliche Abmessungen u. Gewichte



Dimensioni - Dimensions - Abmessungen

RD 62-63

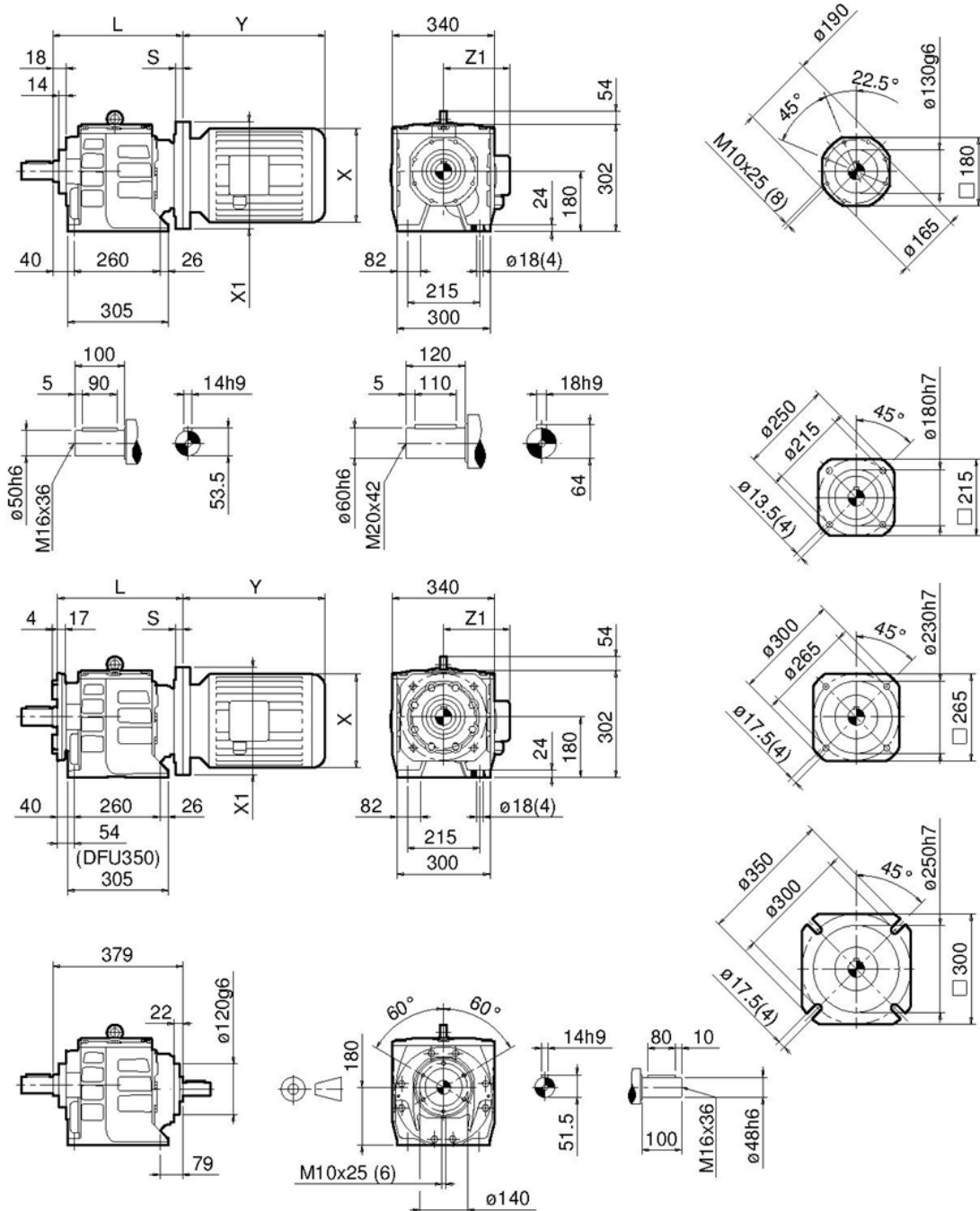



RD	62 / 63	62 / 63	62 / 63	62 / 63	62 / 63	62 / 63	62 / 63	62
IEC	80	90 S	90 L	100	112	132 S/M	160	180
X / Y / Z1	Dimensioni: pag.51 - Dimensions: page 51 - Abmessungen: Seite 51							
X1 (B5) / S	200/16	200/16	200/16	250/16	250/16	300/16	350/25	350/25
X1 (B14) / S	---	---	---	---	---	200/16	---	---
L	379	379	379	379	379	379	410	410
L1 / L1(ø350)	379/393	379/393	379/393	379/393	379/393	379/393	410/424	410/424
Dimensioni e pesi non impegnativi			Not binding dimensions and weights			unverbindliche Abmessungen u. Gewichte		

RD2

**Riduttore a due coppie
Two-stage gearbox
Zweistufig Getriebe**

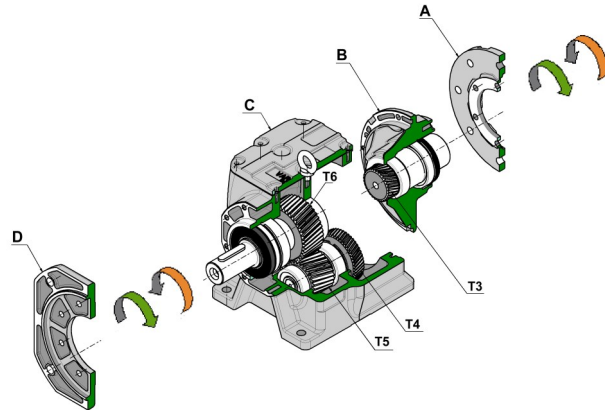
- A - Flangia motore
Motor flange adapter
Motorflansch
- B - Coperchio entrata 2 coppie & pignone T3
2-stage input cover + T3 gear
Zweistufige Eingangsdeckel u. Ritzel T3
- C - Carcassa & ingranaggi T4, T5, T6
Housing + T4, T5, T6 gears
Gehäuse u. Räder T4, T5, T6
- D - Flangia di uscita
Output flange
Abtriebsflansch





-  - Rotazione entrata/uscita
- Input/output rotation
- Eingangs- / Ausgangsdrehrichtung

RD3

**Riduttore a tre coppie
Three-stage gearbox
Dreistufig Getriebe**

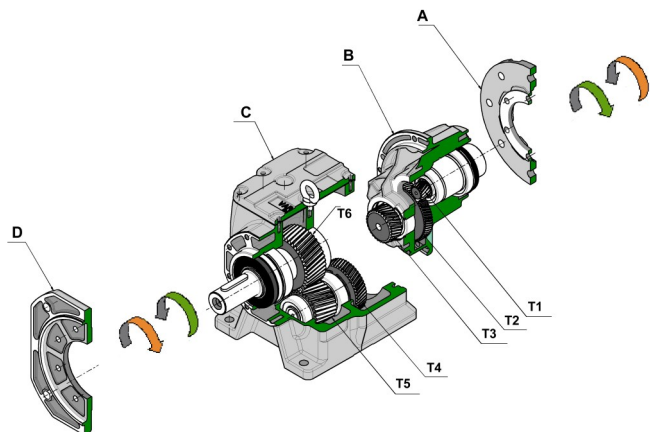
- A - Flangia motore
Motor flange adapter
Motorflansch
- B - Coperchio entrata 3 coppie & ingranaggi T1, T2, T3
3-stage input cover + T1, T2, T3 gears
Dreistufige Eingangsdeckel u. Räder T1, T2, T3
- C - Carcassa & ingranaggi T4, T5, T6
Housing + T4, T5, T6 gears
Gehäuse u. Räder T4, T5, T6
- D - Flangia uscita
Output flange
Abtriebsflansch



-  - Rotazione entrata/uscita
- Input/output rotation
- Eingangs-/Ausgangsdrehrichtung

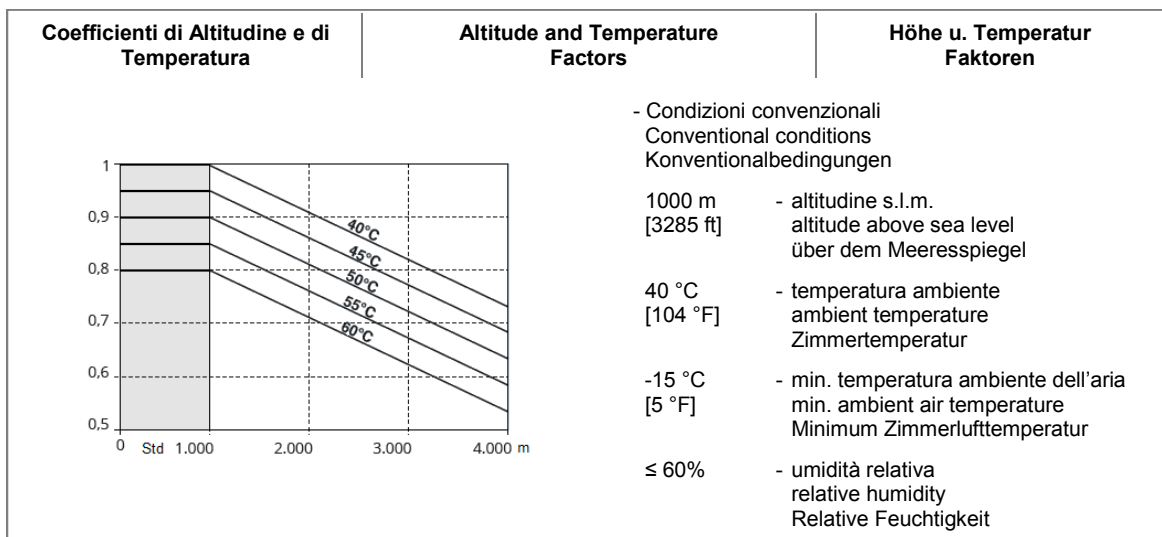
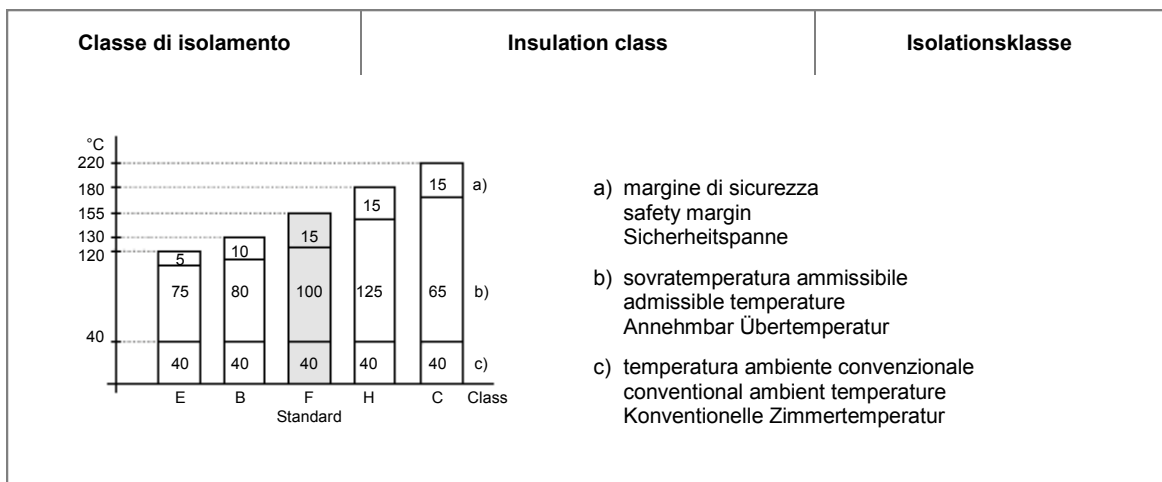
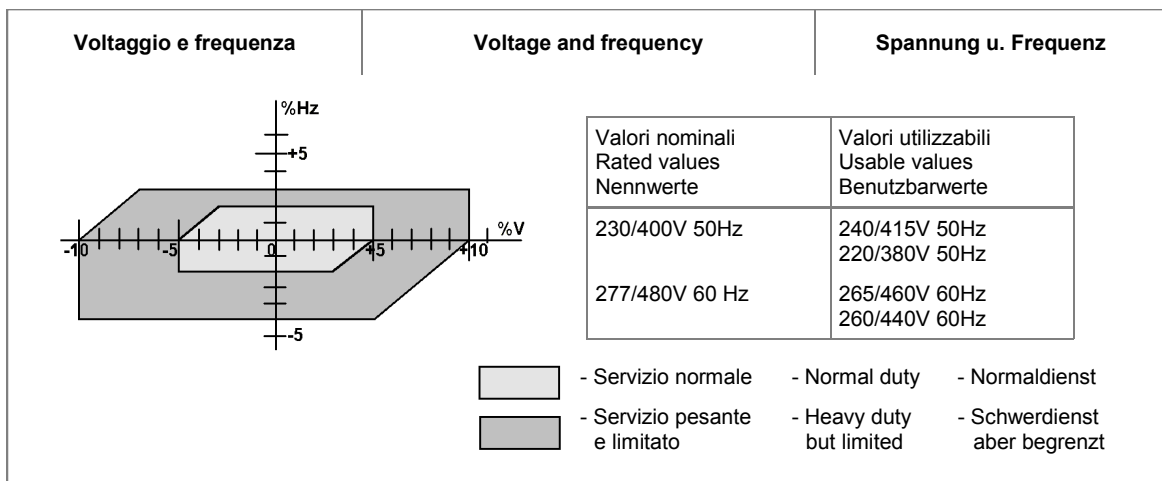

ATEX 2014/34/EU - Direttiva Europea - European Directive - Europäische Richtlinie

La Direttiva Europea 2014/34/UE-ATEX riguarda non solo gli apparecchi elettrici ma tutte le macchine e gli organi di comando che sono destinati, soli o combinati, ad essere utilizzati in atmosfere potenzialmente esplosive nei territori della Comunità Europea.

I riduttori VARVEL-ATEX sono costruiti con

- carcassa e coperchi in materiale metallico, contenenti gli elementi di trasmissione montati su cuscinetti a sfere o a rulli;
- paraolio in fluoro-elastomero FKM (Viton) sugli alberi di entrata e di uscita;
- quantità di lubrificante idonea per assicurare il funzionamento del progetto;
- viteria sigillata con pasta frena-filetti.

I riduttori sono identificati nella Direttiva come «componenti», pertanto privati di loro funzione autonoma, ma essenziali per il funzionamento di apparecchi e di sistemi di protezione destinati alla produzione, trasporto, immagazzinamento, misurazione, regolazione e conversione d'energia e trasformazione dei materiali che, per le loro proprie potenzialità d'infiammabilità, rischiano di provocare l'innesco di un'esplosione.

La serie VARVEL RD è conforme alle specifiche di progetto richieste dal

- Gruppo II
- Categoria 2 e 3
 - zona 1 e zona 2 per funzionamento in zone con pericolo di esplosione in presenza di gas
 - zona 21 e zona 22 per funzionamento in zone con pericolo di esplosione in presenza di polveri combustibili

I prodotti VARVEL-ATEX sono marcati:

- versione con entrata cava/chiavetta



II 2 G Ex h IIC T4 Gb IP66 T_{amb} -20 /+55°C
II 2 D Ex h IIIC T135°C Db IP66 T_{amb} -20 /+55°C

- versione con giunto in acciaio



II 3 G Ex h IIC T5 Gc IP66 T_{amb} -10 /+35°C
II 3 D Ex h IIIC T100°C Dc IP66 T_{amb} -10 /+35°C

The European Directive 2014/34/EC-ATEX relates not only to electric devices but to all the machines and driving units destined, alone or combined, to operate in potentially explosive environments within European Community territory.

The gearboxes VARVEL-ATEX are manufactured

- with metallic housings and covers, containing the driving gears fitted on ball or roller bearings;
- FKM-Fluor-elastomer (Viton) oil seals on input and output shafts;
- the needed oil quantity to ensure the unit operation;
- sealed thread screws with sealing paste.

The gearboxes are identified in the Directive as «components», therefore stripped away any autonomous function, but fundamental to operation of units and protection systems destined to production, transport, storage, measuring, adjusting and conversion of energy and material transformation that because of their own inflammable potentiality, risk to induce an explosion trigger.

VARVEL RD series conforms to design directions required for

- Group II
- Category 2 and 3
 - zones 1 and 2 for operation in zones with risk of explosion in presence of gas
 - zones 21 and 22 for operation in zones with risk of explosion in presence of combustible dust

The VARVEL-ATEX products are marked:

- key/keyway input version

- steel coupling input version

Die Europäische Richtlinie 2014/34/EG-ATEX gilt nicht nur für elektrische Ausrüstungen, sondern auch für alle Arten von Maschinen und Steuerungsteile, allein oder kombiniert, für den Gebrauch in potentiell explosiver Atmosphäre in den Gebieten der Europäischen Gemeinschaft.

- Die VARVEL-ATEX Getriebe sind hergestellt mit
- Gehäuse und Deckel in Metall, beinhaltet Getriebe montiert auf Kugel- oder Rollenlager;
- FKM-Fluorelaste (Viton) Dichtungen auf Eingangs- und Ausgangswellen;
- ausreichende Ölmenge, um das Funktionieren des Projekts zu gewährleisten;
- Schrauben sind mit Schraubensicherungs-paste abgedichtet.

Die Getriebe sind in der Richtlinie als "Komponenten" identifiziert, von daher ihre autonome Funktion, aber wesentlich für den Betrieb von Geräten und Schutzsystemen für die Produktion, Transport, Lagerung, Messung, Regelung und Umwandlung von Energie und Verarbeitung von Materialien, die wegen ihrer eigenen potenzieller Entflammbarkeit, die Auslösung einer Explosion riskieren.

Die VARVEL RD Serie ist entsprechend mit die Konstruktionsanforderungen gebeten von

- Gruppe II,
- Kategorie 2 u. 3,
 - Zone 1 und Zone 2 für Betrieb in Zonen mit Explosionsgefahr in der Gegenwart von Gas,
 - Zone 21 und Zone 22 für Betrieb in Zonen mit Explosionsgefahr in der Gegenwart von Brennstaub.

Die Produkte VARVEL-ATEX sind markiert:

- Paßfeder/Nut Ausführung

- Kupplung aus Stahl Ausführung

Chiave di lettura del Codice ATEX

- II** - Gruppo II (industrie di superficie)
2, 3 - Categoria (2, 3)
G, D - Atmosfera esplosiva (presenza di gas-vapori-nebbie, polveri)
Ex h - Modo di protezione
IIC, IIIC - Gruppo di esplosione (gas, polveri)
T4 - Classe di temperatura (gas)
T135°C - Massima temperatura superficiale (polveri)
Gb, Db - EPL - Explosion Protection Level: (gas, polveri)
IP66 - Protezione riduttore
T_{amb} - Temperatura ambiente (-20 /+55°C) - cava/linguetta (-10 /+35°C) - giunto in acciaio

Key to ATEX Code

- II** - Group II (surface industries)
2, 3 - Category (2, 3)
G, D - Explosive environment (presence of gas-vapours-cloud, dust)
Ex h - Mode of protection
IIC, IIIC - Group of explosion (gas, dust)
T4 - Class of temperature (gas)
T 135°C - Max. temperature of surface (dust)
Gb, Db - EPL - Explosion Protection Level (gas, dust)
IP66 - Protection of gearbox
T_{amb} - Ambient temperature (-20 /+55°C) - key/keyway (-10 /+35°C) - steel coupling

Leseschlüssel des ATEX - Code

- II** - Gruppe II (Oberfläche-Industrien)
2, 3 - Kategorie (2, 3)
G, D - explosionsfähige Atmosphäre (Gegenwart von Gas-Dämpfe-Nebel, Staube)
Ex h - Schutzart
IIC, IIIC - Gruppe der Explosion (Gas, Staube)
T4 - Temperatur-Klasse
T 135°C - Maximale Oberflächentemperatur (Staube)
Gb, Db - EPL - Explosion Protection Level (Gas, Staube)
IP66 - Getriebes Schutz
T_{amb} - Zimmertemperatur (-20 /+55°C) - Paßfeder/Nut (-10 /+35°C) - Kupplung aus Stahl

Sostanze, Zone, Categorie, EPL Substances, Zones, Categories, EPL Substanzen, Zonen, Kategorien, EPL							
Sostanze Substances Substanzen	Zone Zones Zonen	Categorie Categories Kategorien			EPL (Equipment Protection Level)		
Gas, Vapori, Nebbie Gas, Vapours, Cloud Gas, Dämpfe, Nebel	0	1G			Ga		
	1		2G			Gb	
	2			3G			Gc
Polveri Dust Stäube	20	1D			Da		
	21		2D			Db	
	22			3D			Dc
Chiave di lettura - Key code - Leserschlüssel							
Zona Zone	0	Presenza continua di gas esplosivo Continuous occurrence of explosive gas Dauerndes Vorhandensein explosiver Gase					
	1	Presenza occasionale di gas esplosivo Occasional occurrence of explosive gas Gelegentliches Vorhandensein explosiver Gase					
	2	Presenza improbabile di gas esplosivo Unlikely occurrence of explosive gas Unwahrscheinliches Vorhandensein explosiver Gase					
	20	Presenza continua di polveri esplosive Continuous occurrence of explosive dust Dauerndes Vorhandensein explosiver Staub					
	21	Presenza occasionale di polveri esplosive Occasional occurrence of explosive dust Gelegentliches Vorhandensein explosiver Staub					
	22	Presenza improbabile di polveri esplosive Unlikely occurrence of explosive Unwahrscheinliches Vorhandensein explosiver Staub					
Categoria Category Kategorie	1	Apparecchi a livello di protezione molto alto (1G, 1D) Equipment with very high protection level (1G, 1D) Geräte mit sehr hohem Schutz (1G, 1D)					
	2	Apparecchi a livello di protezione alto (2G, 2D) Equipment with high protection level (2G, 2D) Geräte mit hohem Schutz (2G, 2D)					
	3	Apparecchi a livello di protezione normale (3G, 3D) Equipment with normal protection level (3G, 3D) Geräte mit normalem Schutz (3G, 3D)					
EPL	a	Livello di protezione molto alto (Ga, Da) Very high level of protection (Ga, Da) Sehr hohes Schutzniveau (Ga, Da)					
	b	Livello di protezione alto (Gb, Db) High level of protection (Gb, Db) Hohes Schutzniveau (Gb, Db)					
	c	Livello di protezione normale (Gc, Dc) Normal level of protection (Gc, Dc) Normales Schutzniveau (Gc, Dc)					
Attenzione ! I riduttori VARVEL-ATEX non sono certificati per funzionamento nelle aree tratteggiate .		Warning ! VARVEL-ATEX gearboxes are not certified for operation in hatched areas .			Vorsicht ! Die Getriebe VARVEL-ATEX sind für den Anbau in die Gestrichelte Zone nicht zertifiziert.		

ATEX - Dichiarazione di Conformità - Declaration of Conformity - Konformitätzeugnis

RD

VARVEL SpA
Via 2 Agosto 1980, 9
I-40053 - Crespellano-
Valsamoggia BO
Italy

dichiara sotto la propria responsabilità che il prodotto
declares on his own responsibility that the product

**Riduttori
Gearboxes**

**Serie/s RS
Serie/s RT
Serie/s RD
Serie/s RP
Serie/s XA
Serie/s RN
Serie/s RO-RV
Serie/s RO2C**

al quale questa dichiarazione si riferisce, è conforme alla Direttiva
to which this declaration relates to, complies with the Directive

2014/34/EU (ATEX).

La conformità è stata verificata sulla base dei requisiti delle norme o dei documenti normativi
The conformity is under observance of the standard documents

**EN 1127-1: 2011
EN ISO 80079-36:2016
EN ISO 80079-37:2016**

Modo di protezione:
Type of protection:

CE 
**II 2 G Ex h IIC T4 Gb
II 2 D Ex h IIC T135°C Db IP66
T_{amb} -20 / +55°C**

I File Tecnici sono depositati presso l'Organismo Notificato di deposito del fascicolo tecnico

**ATEX 19 RS - RT
ATEX 19 RD - XA - RP,
ATEX 19 RN - RO - RV - RO2C**

The Technical Files are deposited at the Notified Body of Technical File Deposit

**0080 INERIS,
F-60550 Verneuil-en-Halatte, France**

Firma autorizzata - *Authorized Signature*

(Funzione - *Function*)

Luogo e data dell'emissione
Place and Date of Issue **Crespellano-Valsamoggia, .../.../....**

<p>Estratto delle ISTRUZIONI D'USO e MANU-TENZIONE (manuale completo su www.varvel.com)</p> <p>Ai sensi della Direttiva Macchine 2006/42/CE e relativa Linea Guida, i riduttori e i variatori di velocità sono considerati "elementi separati di macchine che non hanno un'applicazione specifica e che sono destinati ad essere incorporati nella macchina. La macchina completa dotata di questi componenti deve soddisfare i requisiti essenziali pertinenti di sicurezza e tutela della salute" della citata Direttiva.</p> <p>Installazione Accertarsi che il gruppo da installare abbia le caratteristiche atte a svolgere la funzione richiesta e che la posizione di montaggio sia coerente con quanto ordinato. Tali caratteristiche sono deducibili dalla targhetta d'identificazione apposta sul riduttore. Effettuare la verifica della stabilità del montaggio affinché non si verifichino vibrazioni o sovraccarichi durante il funzionamento.</p> <p>Funzionamento Il riduttore può essere collegato per rotazione oraria o antioraria. Arrestare immediatamente il riduttore in caso di funzionamento difettoso o di rumorosità anomala, rimuovere il difetto o ritornare l'apparecchio alla fabbrica per un'adeguata revisione. Se la parte difettosa non è sostituita, anche altri componenti possono essere danneggiati con conseguenti ulteriori danneggiamenti e più scarsa possibilità di risalire alle cause.</p> <p>Manutenzione Sebbene i gruppi siano provati con funzionamento senza carico prima della spedizione, è consigliabile non usarli a carico massimo durante le prime 20-30 ore di funzionamento affinché le parti interne possano adattarsi reciprocamente. I riduttori sono spediti già riempiti con olio sintetico a lunga durata e, se occorre sostituire o rabboccare il lubrificante, non mescolare oli a base sintetica con oli a base minerale.</p> <p>Movimentazione In caso di sollevamenti con paranco, utilizzare posizioni di aggancio sulla struttura della carcassa, golfari ove esistenti, fori dei piedi o sulle flange, evitando tutte le parti mobili.</p> <p>Verniciatura Qualora il gruppo subisca una verniciatura successiva, è necessario proteggere accuratamente gli anelli di tenuta, i piani di accoppiamento e gli alberi sporgenti.</p> <p>Conservazione prolungata a magazzino Per permanenze maggiori di tre mesi, è consigliata l'applicazione di antiossidanti su alberi esterni e piani lavorati, e di grasso protettivo sui labbi dei paraoli.</p> <p>Gestione Ambientale del prodotto In conformità alla Certificazione Ambientale ISO 14001, sono suggerite le seguenti indicazioni per lo smaltimento del nostro prodotto:</p> <ul style="list-style-type: none"> - i componenti del gruppo che vengono rottamati debbono essere consegnati a centri di raccolta autorizzati per i materiali metallici; - gli oli ed i lubrificanti raccolti dal gruppo devono essere smaltiti consegnandoli ai Consorzi Oli esausti; - gli imballi a corredo dei gruppi (pallet, cartone, carta, plastica, ecc.) vanno avviati per quanto più possibile al recupero/riciclo, consegnandoli a ditte autorizzate per le singole classi di rifiuto. 	<p>Abstract of OPERATION and MAINTENANCE INSTRUCTIONS (complete manual on www.varvel.com)</p> <p>Under the terms of the Machine Directive 2006/42/EC and relevant Guidelines, the speed gearboxes and variators are considered as "machines' separate elements not having a specific application and meant for being incorporated onto the machine. The complete machine and equipped with such components must comply with the essential and relevant requisites for safety and health preservation" of the mentioned Directive.</p> <p>Installation Check if the unit to be installed, is properly selected to perform the required function and that its mounting position complies with the order. The nameplate reports such information. Check mounting stability to ensure the unit runs without vibrations or overloads.</p> <p>Running The unit may be connected for clockwise or counter-clockwise rotation. The unit must be stopped as soon as defective running or unexpected noise occur, remove the faulty part or return the unit to the factory for checking. If the faulty part is not replaced, other parts can also be affected, causing more severe damage and making the identification of initial cause more difficult.</p> <p>Maintenance Although the units are no-load run tested in the factory before despatch, it is recommended not to run them at maximum load for the first 20-30 running hours to allow the proper running in. The gearboxes are delivered already filled with long-life synthetic oil and, in case of replacement or topping, do not mix with mineral lubricants.</p> <p>Handling When hoisting, use relevant housing locations or eyebolts if provided, or foot or flange holes. Never hoist on any moving part.</p> <p>Painting Carefully protect oil seals, coupling faces and shafts when units are repainted.</p> <p>Long-term storage For storages longer than three months, apply antioxidants onto shafts and machined surfaces, and protective grease on oil seal lips.</p> <p>Product's Environmental Management In conformity with Environmental Certification ISO 14001, we recommend the following to dispose of our products:</p> <ul style="list-style-type: none"> - scraped components of the units to be delivered to authorized centres for metal object collection; - oils and lubricants drained from the units to be delivered to Exhausted Oil Unions; - packages (pallets, carton boxes, paper, plastic, etc.) to lead into regeneration/recycling circuits as far as possible, by delivering separate waste classes to authorized companies. 	<p>Zusammenfassung der BETRIEBS- u. WARTUNGSANWEISUNGEN (vollständiges Handbuch auf www.varvel.com)</p> <p>Gemäß der Maschinenrichtlinie 2006/42/EC und der zugehörigen Richtlinie gelten Getriebe und Verstellgetriebe als "separate Elemente von Maschinen, die keine spezifische Anwendung haben und die in der Maschine eingebaut werden sollen. Die gesamte Maschine, die mit diesen Komponenten ausgerüstet ist, muss den einschlägigen grundlegenden Sicherheits- und Gesundheitsanforderungen der vorgenannten Richtlinie entsprechen.</p> <p>Aufstellung Vor der Aufstellung ist zu prüfen, dass die Antriebseinheit in Bezug auf die Betriebsbedingungen richtig ausgewählt wurde und die Einbaulage mit der Bestellung übereinstimmt. Angaben hierüber sind auf dem Typenschild zu finden. Die Stützkonstruktion für die Getriebe ist so stabil auszuführen, dass keine Schwingungen oder Überlastungen auftreten, eventuell sind elastische Kupplungen oder Drehmomentbegrenzer zu verwenden.</p> <p>Inbetriebnahme Die Antriebseinheit kann in beiden Drehrichtungen eingesetzt werden. Die Einheit muss sofort angehalten werden, wenn ein unzulässiger Lauf oder unerwartete Geräusche auftreten. Das fehlerhafte Teil ist zu ersetzen oder die Einheit ist zur Überprüfung einzuschicken, Falls das fehlerhafte Teil nicht ersetzt wird, kann dies zu weiteren Schäden an anderen Bauteilen führen, was eine Feststellung der Ursachen sehr schwierig machen kann.</p> <p>Wartung Obwohl die Einheiten vor der Auslieferung im Leerlauf getestet wurden, ist es ratsam sie in den ersten 20-30 Stunden nicht mit Volllast zu betreiben, um ein einwandfreies Einlaufen zu gewährleisten. Die Einheiten werden entsprechend den Angaben auf dem Typenschild mit synthetischem Schmierstoff Lebensdauer geschmiert ausgeliefert. Bei einem eventuellen Ölwechsel oder Nachfüllen darf der Schmierstoff nicht mit Mineralöl vermischt werden.</p> <p>Handhabung und Transport Beim Heben und Transport ist auf standsichere Lage und sorgfältige Befestigung geeigneter Hebevorrichtungen zu achten, Bewegliche Teile dürfen nicht zum Anheben benutzt werden.</p> <p>Anstrich Beim Erneuern oder dem zusätzlichen Aufbringen eines Anstriches sind die Dichtungen, Kupplungssitze und Wellen sorgfältig zu schützen.</p> <p>Langzeitlagerung Die Einlagerung der Einheiten muss trocken und staubfrei erfolgen, Bei einer Einlagerungszeit über 3 Monate sind bearbeitete Flächen und Wellen mit Rostschutzmitteln zu besprühen, Dichtlippen sind mit Fett zu schützen.</p> <p>Entsorgung In Übereinstimmung mit ISO 14001 weisen wir darauf hin, im Falle des Verschrottens die einzelnen Metallteile getrennt zu behandeln und Schmiermittel bei den befugten Stellen zu entsorgen. Verpackungen sollten soweit wie möglich wieder verwendet werden.</p>
<p>Liberatoria Il presente catalogo annulla e sostituisce i precedenti. Le dimensioni e pesi non sono impegnativi VARVEL si riserva il diritto di apportare modifiche senza preavviso. È vietata la riproduzione anche parziale senza preventiva autorizzazione.</p>	<p>Disclaimer This catalogue cancels and replaces the previous ones. Dimensions and weights are not binding. VARVEL reserves the right to make changes without notice. Reproduction, even partial, is prohibited without prior authorization.</p>	<p>Haftungsausschluss Dieser Katalog löscht und ersetzt die vorherigen Kataloge. Abmessung u. Gewichte sind unverbindliche. VARVEL behält sich das Recht vor, unangekündigte Änderungen vorzunehmen. Die teilweise Vervielfältigung ohne vorherige Genehmigung ist untersagt.</p>