

Precision Machine Tool Acc

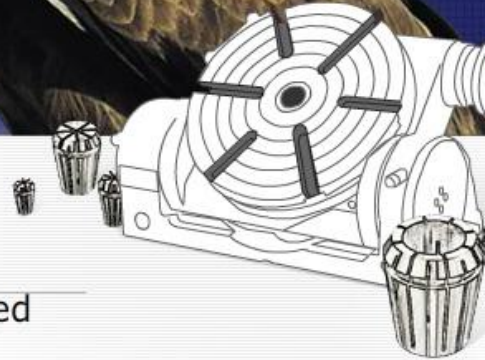

Accuracy Responsibility
Cooperative Speed



VERTEX MACHINERY WORKS CO., LTD was established in 1978.



VERTEX - SPECIALIZE in MANUFACTURING high PRECISION ACCESSORIES for MILLING & GRINDING & LATHE MACHINE & MACHINE CENTER. VERTEX HAS 10, 000 m² FACTORY LOCATED INSIDE CENTER OF FENG-YUAN CITY,TAICHUNG,TAIWAN.

Regarding TO VERTEX - MARKET Sales, 70% is foreign and 30% is domestic.

According to TAITRA - Taiwan External Trade Development Council, VERTEX - is the LARGEST,BIGGEST MACHINE TOOL ACCESSORIES MAKER & EXPORTER in Taiwan.

VERTEX's Spirit is - ACCURACY & SPEED & RESPONSIBILITY & COOPERATIVE.

VERTEX - TEAMS are always RESEARCHING and DEVELOPING new products & innovating new designs to meet the market trends,

VERTEX also pay attention to sufficient stock to make short delivery and supply HIGH QUALITY - VERTEX PRECISION products to give customers more confidence and satisfaction.TW

VERTEX - IS not only a ACCESSORIES/TOOLING MANUFACTURER but also a reliable business PARTNER.



ORDER NO.	FOR TAP	SPEED	WORK RANGE	WEIGHT	CODE NO.	Inquiry
VAT-1920	M10-M20	180/ 200 RPM	Rmax 1900mm Rmin 200mm	26	3404-430	Inquiry
VAT-1922	M12-M22	185/ 205 RPM	Rmax 1900mm Rmin 200mm	26	3404-431	Inquiry
VAT-1924	M14-M24	90/ 100 RPM	Rmax 1900mm Rmin 200mm	28	3404-431A	Inquiry

Air Tapping Arm Unit,VAT-1920,1922 氣動式攻牙機,"ARM AIR TAPPING",V A T,tapping
Air tapping unit,arm tapping,VAT-1920

Precision Drill Grinder



NEW



For Drill Re-sharpening
Precision, Efficient, Easy operation, Reasonable price,
Short processing time, Grinding Angle
90-140 Degree, Grinding Diameter from 2-13 mm.
Reasonable Price, Fast

1. High Efficiency, High Quality Grinding Lip, Good Grinding Results
2. Quality Assurance: $\pm 0.05\text{mm}$
3. Easy Operation, For Urgent Need
4. Considerable Design, Invisible Tool Box, Delicate & Friendly Use
5. Peerless, Super Function, Durable, strong Motor can work for 2 hours.
6. The grinding angle from 90-140 degree can be re-sharpened, AND drill, center drill, carbide NC spot drill.
 Suit for the drill process on steel, casting iron, brass and aluminum.
7. The allowable grind diameter from 2-13 mm.

CHECKING STOCK
 FOR SET THE DRILL OF LENGTH
 & THE WEB BLADE PARALLEL
 WITH THE SLOT OF CLAMPING
 HOLDER.

SLOT

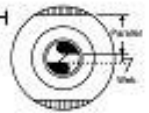

GRINDER WHEEL

ORDER NO.	FOR DRILL MATERIAL	WHEEL	CODE NO.
VDG-13B	HSS	CBN200	8001-500
VDG-13D	CARBIDE	SDC200	8001-501
VDG-20B	HSS	CBN200	8001-502
VDG-20D	CARBIDE	SDC200	8001-503
VDG-25B	HSS	CBN200	8001-504
VDG-25D	CARBIDE	SDC200	8001-505

ORDER NO.	COLLET TYPE	COLLET Q'TY	CAPACITY MAX. DIA	CODE NO.
VDG-13A	ER-20	11pcs	$\varnothing 13$	8001-012
VDG-20	ER-32	13pcs	$\varnothing 20$	8001-013
VDG-25	ER-40	14pcs	$\varnothing 26$	8001-014



VDG-25

	VDG-13A	VDG-20	VDG-25
DRILL DIAMETER	$\varnothing 2.0 \sim \varnothing 13.0$	$\varnothing 8 \sim \varnothing 20$	$\varnothing 12 \sim \varnothing 26$
CENTER POINT ANGLE	$90^\circ \sim 140^\circ$	$90^\circ \sim 140^\circ$	$100^\circ \sim 136^\circ$
POWER SUPPLY	AC-110 or 220 1PH	AC-110 or 220 1PH	AC-110 or 220 1PH
R.P.M. OF MOTOR	5100 R.P.M.	3280 R.P.M.	5300 R.P.M.
GRINDING WHEEL	CBN #200	CBN #230	CBN #200
NET WEIGHT	AC-110:9.7kgs AC-220:9.7kgs	AC-110:19.8kgs AC-220:19.8kgs	AC-110:29kgs AC-220:29kgs
OVERALL DIMENSIONS	W282xD185xH110mm	W360xD215xH180mm	W380xD240xH200mm
STANDARD ACCESSORIES	ALLOY STEEL COLLET ER-20 COLLETx11PCS $\varnothing 3, 4, 5, 6, 7, 8, 9, 10, 11, 12, 13$, EACH ONE COLLET HOLDER X 1 UNIT 4mm HEXAGON WRENCH X 1PCS FOR CHANGE WHEEL	ALLOY STEEL COLLET ER-32 COLLETx13PCS $\varnothing 8, 9, 10, 11, 12, 13, 14, 15, 16, 17, 18, 19, 20$, EACH ONE COLLET HOLDER X 1 UNIT 5mm HEXAGON WRENCH X 1PCS SPACER 0.1mm x 2pcs, 3.0mm x 1 pcs FOR CHANGE WHEEL	ALLOY STEEL COLLET ER-40 COLLETx14PCS $\varnothing 12, 13, 14, 15, 16, 17, 18, 19, 20, 21, 22, 23, 24, 26$, EACH ONE COLLET HOLDER X 1 UNIT 4mm HEXAGON WRENCH X 1PCS FOR CHANGE WHEEL

COLLET

Alloy Steel Collet:ER-20, $\varnothing 3.5, 4.5, 5.5, 6.5, 7.5, 8.5, 9.5, 10.5, 11.5, 12.5$
Alloy Steel Collet:ER-32, \varnothing STANDARD SIZE ONLY
Alloy Steel Collet:ER-40, $\varnothing 27, 28, 29, 30$ FOR SPECIAL SIZE

- VDG-25 allows up to size $\varnothing 30\text{mm}$, please choose optional collet $\varnothing 27, \varnothing 28, \varnothing 29, \varnothing 30\text{mm}$.

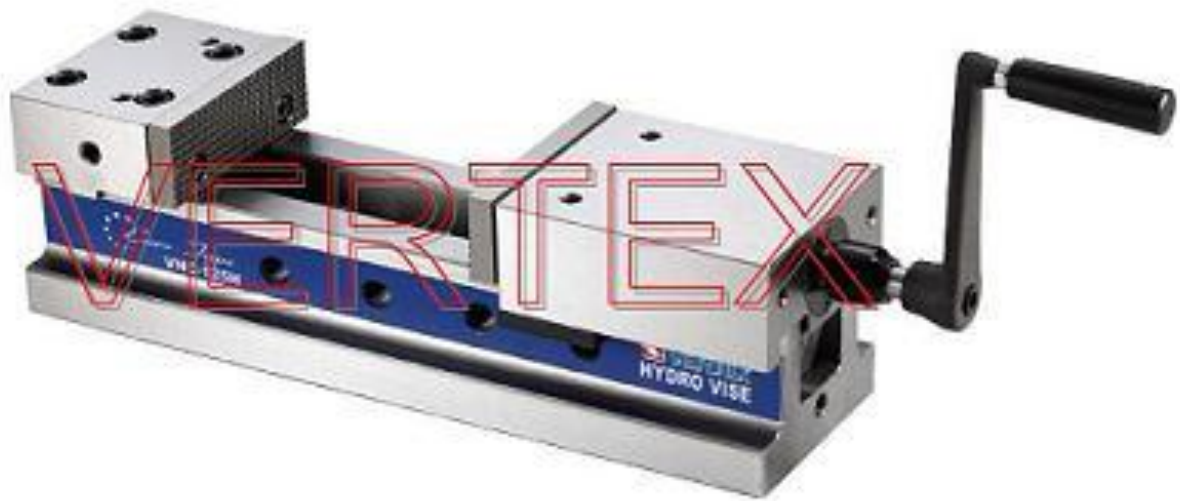

ORDER NO.	LxWxH	JAW OPENING	JAW HEIGHT	Max. Clamp Force	WEIGHT	CODE NO.	Inquiry
VNC-100H	464X99.6X103.5mm	205mm	34mm	25KN	19KGS	4005-100	Inquiry

VERTEX NC HYDRO MACHINE VISE VNC-100H,125H,160H,160LH,
 台灣鷹牌油壓式虎鉗

NEW DESIGN FEATURES

- *COMPARE TO OTHERS
- VERTEX VNC SERIES VISE HAS THE BIGGEST VISE JAW OPEN AMONG THE OTHER VISE HAS SAME JAW WIDTH.
- *GOOD MATERIAL
- *COMPACT
- *HYDRO BOOST SYSTEM
- FOR VERTEX NC HYDRO MACHINE VISE DETAILS, PLEASE CONTACT OFFICE.



Quick Change Tool Post & Holders

-Italian Style

NEW



www.vertex-tw.com.tw

..



Quick Change Tool Post & Holders-Italian Style

MAIN BODY DIMENSIONS

ORDER NO.	Lathe swing	B	D ^{H7}	H		C	E	T _{max}	F	V _{max}	Ø _{max}	Morse NO.	ØD	G	H1		
				Min	Max												
VTP-M	180-250	57.7	18	24	34	45	8	16	56	10	14	1	7	27	18	70	
VTP-AR-AP	250-300	64.5	18	25	41	56	9	16	63	16	16	1	8	30	16	80	
VTP-A	250-350	82.0	24	32	42	60	12	20	75	10	18	2	10	35	20	100	
VTP-BR-BP	300-380	91.6	28	38	53	75	13	25	90	17	20	3	10	40	20	115	
VTP-B	350-500	100.0	30	47	65	85	15	32	100	15	24	3	12	48.2	25	127	
VTP-C	500-650	115.3	38	51	72	94	19	32	108	24	26	4	14	58.2	26	145	



ORDER NO.	H1	H2	CHUCK	WEIGHT	MAKER	APPLICATION	CODE NO.	Inquiry
HJ05	53	23	N-205	0.4	VERTEX	LATHE CHUCK	5002-401	Inquiry
HJ06	67.5	31	N-206,V-206	1.0	VERTEX	LATHE CHUCK	5002-402	Inquiry
HJ08	86	35	N-208,V-208	1.9	VERTE X	LATHE CHUCK	5002-403	Inquiry
HJ10	99.5	40	N-210,V-210	2.9	"VERTEX"	LATHE,CHUCK	5002-404	Inquiry
HJ12	103	50	N-212	2.65	VERTEX	"LATHE CHUCK"	5002-405	Inquiry
HJ12-1	103	50	V-212	2.7	VERTE X	"LATHE","CHUCK"	5002-406	Inquiry
HJ15	149	62	N-215	9.6	"VERTEX"	"LATHE CHUCKS"	5002-407	Inquiry
HJ15-1	149	62	V-215	9.5	VERTEX	MACHINE LATHE CHUCK	5002-408	Inquiry

**VERTEX CHUCK HARD JAWS - HYDRAULIC
POWER CHUCK JAWS, HJ SERIES, 油壓硬爪**



MC Power Vise

NEW

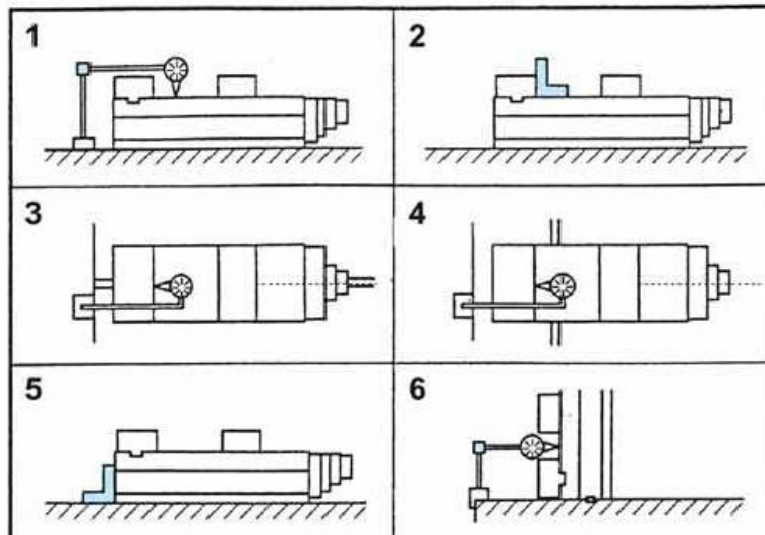

INSPECTION SPECIFICATION

NO.	Inspection Item	Per (100mm)	Guarantee
1	Parallelism:running face to bottom of bed.		0.01mm
2	Squareness:between running face and jaw plate.		0.03mm
3	Squareness:both sides to fixed jaw plate.		0.02mm
4	Parallelism:keways on bottom of bed to jaw plate.		0.02mm
5	Parallelism:running face of the test block to bottom of bed.		0.02mm
6	Lift can be controlled when clamping test block.		0.015mm

WISE SERIES

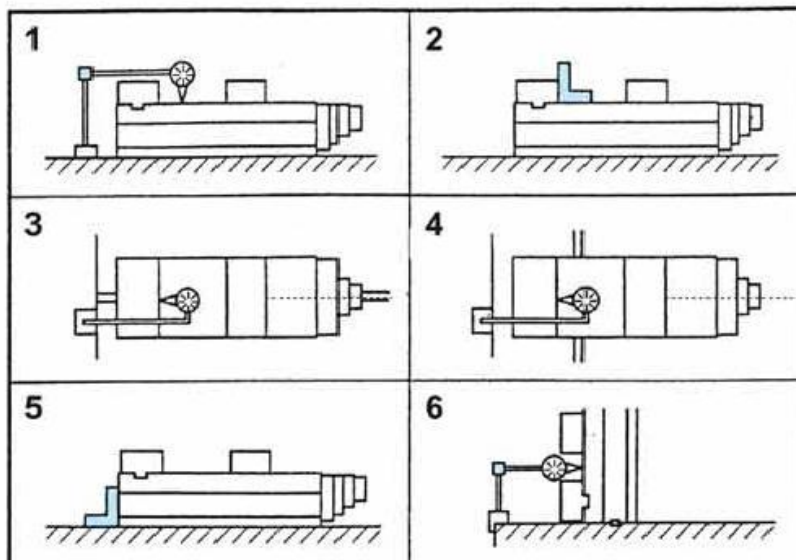

INSPECTION SPECIFICATION

NO.	Inspection Item	Per (100mm)	Guarantee
1	Parallelism:running face to bottom of bed.		0.01mm
2	Squareness:between running face and jaw plate.		0.03mm
3	Squareness:both sides to fixed jaw plate.		0.02mm
4	Parallelism:keways on bottom of bed to jaw plate.		0.02mm
5	Parallelism:running face of the test block to bottom of bed.		0.02mm
6	Lift can be controlled when clamping test block.		0.015mm



維昶機具廠有限公司

VERTEX MACHINERY WORKS CO. ,LTD.

台中市豐原區豐勢路一段 296 號 **NO.296, SEC. 1,FENG SHIH ROAD,FENG YUAN , TAICHUNG , TAIWAN.**

TEL : 886 - 4 - 25238742 / 25237596 / 25237621~22 FAX : 886 - 4 - 25234823 / 25205905

http : www.vertex-tw.com.tw E-mai : vertex.huang@msa.hinet.net vertex.co@msa.hinet.net